

SAN FRANCISCO PUBLIC UTILITIES COMMISSION
STORMWATER MANAGEMENT REQUIREMENTS AND DESIGN GUIDELINES

APPENDIX B:

GREEN INFRASTRUCTURE
TYPICAL DETAILS

(JANUARY 2023, VERSION 3.0)



Services of the San Francisco
Public Utilities Commission

SHEET NO.	SHEET TITLE	SHEET NO.	SHEET TITLE	SHEET NO.	SHEET TITLE
GENERAL INFORMATION		BP 5.3	PARCEL PLANTER PLAN - ALTERNATIVE 1	IG 1.4	PRETREATMENT GUIDANCE (1 OF 2)
GEN 0.1	USER GUIDE	BP 5.4	PARCEL PLANTER PLAN - ALTERNATIVE 2	IG 1.5	PRETREATMENT GUIDANCE (2 OF 2)
GEN 0.2	INFILTRATION-BASED BMP GUIDANCE	BP 5.5	PARCEL PLANTER - RAISED PLANTER SECTION	IG 2.1	LARGE SYSTEMS - PLAN
PERMEABLE PAVEMENT (PP)		BP 5.6	PARCEL PLANTER - AT GRADE PLANTER SECTION	IG 2.2	LARGE SYSTEMS - SECTION
PP 1.1	DESIGNER NOTES (1 OF 2)	BP 5.7	PARCEL PLANTER - PLANTER ON STRUCTURE SECTION	IG 3.1	MEDIUM SYSTEMS - PLAN
PP 1.2	DESIGNER NOTES (2 OF 2)	BIORETENTION BASIN (BB)		IG 3.2	MEDIUM SYSTEMS - SECTION
PP 1.3	KEY MAP	BB 1.1	DESIGNER NOTES	IG 4.1	SMALL SYSTEMS - PLAN
PP 2.1	MATERIAL SECTIONS - PERMEABLE UNIT PAVERS	BB 2.1	ROADSIDE SECTION	IG 4.2	SMALL SYSTEMS - SECTION
PP 3.1	MATERIAL SECTIONS - PERVIOUS CONCRETE	BB 2.2	PARCEL SECTION	VEGETATED ROOF (VR)	
PP 4.1	MATERIAL SECTIONS - POROUS ASPHALT	BIORETENTION COMPONENTS (BC)		VR 1.1	DESIGNER NOTES (1 OF 2)
PAVEMENT COMPONENTS (PC)		BC 1.1	EDGE TREATMENTS - DESIGNER NOTES	VR 1.2	DESIGNER NOTES (2 OF 2)
PC 1.1	EDGE TREATMENTS - DESIGNER NOTES	BC 1.2	EDGE TREATMENTS - VEHICULAR APPLICATIONS (1 OF 2)	VR 2.1	VEGETATED ROOF - EXTENSIVE AND SEMI-INTENSIVE
PC 1.2	EDGE TREATMENTS - KEY MAP	BC 1.3	EDGE TREATMENTS - VEHICULAR APPLICATIONS (2 OF 2)	VR 2.2	VEGETATED ROOF - INTENSIVE
PC 1.3	EDGE TREATMENTS - VEHICULAR APPLICATIONS	BC 1.4	EDGE TREATMENTS - PEDESTRIAN APPLICATIONS (1 OF 2)	GENERAL COMPONENTS (GC)	
PC 1.4	EDGE TREATMENTS - PEDESTRIAN APPLICATIONS (1 OF 2)	BC 1.5	EDGE TREATMENTS - PEDESTRIAN APPLICATIONS (2 OF 2)	GC 1.1	LINERS - DESIGNER NOTES
PC 1.5	EDGE TREATMENTS - PEDESTRIAN APPLICATIONS (2 OF 2)	BC 1.6	EDGE TREATMENTS - LATERAL BRACING (1 OF 2)	GC 1.2	LINERS - LINERS AND ATTACHMENTS
PC 1.6	EDGE TREATMENTS - PAVER AT STRUCTURES	BC 1.7	EDGE TREATMENTS - LATERAL BRACING (2 OF 2)	GC 2.1	UTILITY CROSSINGS - DESIGNER NOTES (1 OF 2)
PC 2.1	SUBSURFACE CHECK DAMS - DESIGNER NOTES	BC 2.1	INLETS - DESIGNER NOTES	GC 2.2	UTILITY CROSSINGS - DESIGNER NOTES (2 OF 2)
PC 2.2	SUBSURFACE CHECK DAMS	BC 2.2	INLETS - CURB CUT WITH GUTTER MODIFICATION	GC 2.3	UTILITY CROSSINGS - BIORETENTION
PC 3.1	SUBSURFACE OVERFLOWS - DESIGNER NOTES	BC 2.3	INLETS - CURB CUT AT BULB OUT	GC 2.4	UTILITY CROSSINGS - BIORETENTION SECTIONS (1 OF 2)
PC 3.2	SUBSURFACE OVERFLOW	BC 2.4	INLETS - CURB CUT WITH TRENCH DRAIN	GC 2.5	UTILITY CROSSINGS - BIORETENTION SECTIONS (2 OF 2)
PC 3.3	SUBSURFACE UNDERDRAIN	BC 3.1	OUTLETS - DESIGNER NOTES	GC 2.6	UTILITY CROSSINGS - PERMEABLE PAVEMENT
PC 3.4	UNDERDRAIN PIPE	BC 3.2	OUTLETS - CURB CUT	GC 2.7	UTILITY CROSSINGS - PAVEMENT SECTIONS (1 OF 2)
BIORETENTION PLANTER (BP)		BC 3.3	OUTLETS - CURB CUT WITH TRENCH DRAIN	GC 2.8	UTILITY CROSSINGS - PAVEMENT SECTIONS (2 OF 2)
BP 1.1	ROADSIDE PLANTER DESIGNER NOTES (1 OF 2)	BC 3.4	OUTLETS - OVERFLOW STRUCTURES	GC 2.9	UTILITY CROSSINGS - LINER PENETRATIONS
BP 1.2	ROADSIDE PLANTER DESIGNER NOTES (2 OF 2)	BC 4.1	AGGREGATE STORAGE LAYERS	GC 2.10	UTILITY CROSSINGS - WALL PENETRATIONS (1 OF 2)
BP 2.1	ROADSIDE PLANTER WITH PARKING - PLAN	BC 5.1	UNDERDRAINS - DESIGNER NOTES	GC 2.11	UTILITY CROSSINGS - WALL PENETRATIONS (2 OF 2)
BP 2.2	ROADSIDE PLANTER WITH PARKING - SECTIONS	BC 5.2	UNDERDRAINS	GC 2.12	UTILITY CROSSINGS - UTILITY TRENCH DAM
BP 3.1	ROADSIDE PLANTER WITHOUT PARKING - PLAN	BC 5.3	UNDERDRAIN ORIFICE CONTROL	GC 3.1	UTILITY CONFLICTS - DESIGNER NOTES
BP 3.2	ROADSIDE PLANTER WITHOUT PARKING - SECTIONS	BC 6.1	CHECK DAMS - DESIGNER NOTES	GC 3.2	UTILITY CONFLICTS - STREET/TRAFFIC LIGHT POLES (1 OF 2)
BP 4.1	ROADSIDE BULBOUT PLANTER - ALTERNATIVE 1	BC 6.2	CHECK DAMS	GC 3.3	UTILITY CONFLICTS - STREET/TRAFFIC LIGHT POLES (2 OF 2)
BP 4.2	ROADSIDE BULBOUT PLANTER - ALTERNATIVE 2	BC 7.1	OUTLET MONITORING - DESIGNER NOTES	GC 3.4	UTILITY CONFLICTS - PARKING METERS
BP 4.3	ROADSIDE BULBOUT PLANTER - ALTERNATIVE 3	BC 7.2	OUTLET MONITORING - EXTERNAL ACCESS STRUCTURE	GC 4.1	OBSERVATION PORTS - DESIGNER NOTES
BP 4.4	ROADSIDE BULBOUT PLANTER - ALTERNATIVE 4	BC 7.3	OUTLET MONITORING - INTERNAL CATCH BASIN MONITORING	GC 4.2	OBSERVATION PORTS - BIORETENTION
BP 4.5	ROADSIDE BULBOUT PLANTER - ALTERNATIVE 5	INFILTRATION GALLERY (IG)		GC 4.3	OBSERVATION PORTS - PERMEABLE PAVEMENT
BP 4.6	ROADSIDE BULBOUT PLANTER - ALTERNATIVE 6	IG 1.1	DESIGNER NOTES (1 OF 3)	GC 5.1	CLEANOUTS
BP 5.1	PARCEL PLANTER - DESIGNER NOTES (1 OF 2)	IG 1.2	DESIGNER NOTES (2 OF 3)	GC 6.1	END-OF-BLOCK MONITORING - DESIGNER NOTES
BP 5.2	PARCEL PLANTER - DESIGNER NOTES (2 OF 2)	IG 1.3	DESIGNER NOTES (3 OF 3)	GC 6.2	END-OF-BLOCK MONITORING

NOT FOR CONSTRUCTION - REFER TO USER GUIDE



**GREEN INFRASTRUCTURE
TYPICAL DETAILS**
SAN FRANCISCO PUBLIC UTILITIES COMMISSION

DATE	JANUARY 2023
VERSION	3.0
REVISED	

SHEET INDEX

CLICK ON SHEET NUMBERS/TITLES FOR LINK TO SHEETS.

DWG NO.

USER GUIDE: HOW TO USE THESE GI TYPICAL DETAILS

THESE TYPICAL DETAILS AND SPECIFICATIONS WERE DEVELOPED TO BE **REVISED AND CUSTOMIZED FOR EACH INDIVIDUAL PROJECT BY DESIGN PROFESSIONALS**.

THEY SHOW **TYPICAL** CONFIGURATIONS, RATHER THAN A REQUIRED CITY **STANDARD** CONFIGURATION. THIS DISTINCTION IS DELIBERATE. WE RECOGNIZE THAT TO CREATE GI PROJECTS THAT ARE FUNCTIONAL, CONTEXTUAL, AND AESTHETIC, DESIGN PROFESSIONALS MUST USE THEIR PROFESSIONAL JUDGMENT AND CREATIVE THINKING TO BE RESPONSIVE TO EACH SITE-SPECIFIC CONDITION.

ACAD DRAWINGS OF THESE TYPICAL DETAILS ARE PROVIDED SUCH THAT THE DESIGN PROFESSIONALS MUST MODIFY THE PLAN, SECTIONS, CALL-OUTS, AND/OR CONSTRUCTION NOTES TO ADDRESS THE PROJECTS SITE-SPECIFIC CONDITIONS.

CONTENT

THESE TYPICAL DETAILS ARE FORMATTED, ORGANIZED, AND DEVELOPED WITH THE NECESSARY INFORMATIONAL TOOLS TO GUIDE THE DESIGN PROFESSIONAL THROUGH THE PROPER SELECTION, LAYOUT, AND DESIGN OF **GI BEST MANAGEMENT PRACTICES (BMPS)** AND THE SELECTION OF APPROPRIATE SITE-SPECIFIC BMP **COMPONENT DETAILS** (I.E. INLETS, OUTLETS, AND EDGE TREATMENTS, ETC.). THESE TYPICAL DETAILS PROVIDE THE FOLLOWING ORGANIZATION:

PURPOSE: SUMMARY OF EACH FACILITY'S INTENDED PERFORMANCE AND FUNCTION.

DESIGNER NOTES & GUIDELINES: TECHNICAL DESIGN REQUIREMENTS AND/OR SIZING CRITERIA GUIDELINES ARE PROVIDED TO ENSURE THAT EACH FACILITY IS DESIGNED AND APPROPRIATELY CUSTOMIZED BY THE DESIGN PROFESSIONAL.

LAYOUT REQUIREMENTS: TECHNICAL INFORMATION, DESIGN REQUIREMENTS, AND REFERENCE TO RELATED CITY REQUIREMENTS.

DESIGNER CHECKLIST: TECHNICAL DESIGN INFORMATION THAT **MUST** BE DETERMINED AND SHOWN IN THE CONSTRUCTION DOCUMENTS TO ENSURE PROPER DESIGN AND CONSTRUCTABILITY.

BMP PLANS: TYPICAL PLAN VIEW WITH GENERAL CONFIGURATION FOR PROPER FUNCTION. DIMENSIONAL LAYOUT AND EDGING MATERIALS SHOULD BE ADJUSTED BASED ON PROPOSED SITE DESIGN AND PROGRAMING. **[ADJUST ACAD DETAIL CALL-OUTS AND REFERENCES FOR USE IN CDs]**

BMP SECTIONS AND PROFILES: A TYPICAL SECTION AND/OR PROFILE WITH GENERAL CONFIGURATION FOR PROPER FUNCTION. DIMENSIONAL LAYOUT AND EDGING MATERIALS SHOULD BE ADJUSTED BASED ON PROPOSED SITE DESIGN AND PROGRAMING. **[ADJUST ACAD DETAILS CALL-OUTS AND REFERENCES FOR USE IN CDs]**

CONSTRUCTION NOTES: CONSTRUCTION RELATED NOTES FOR USE BY THE CONTRACTOR. **[ADJUST ACAD NOTES FOR USE IN CDs]**

NAVIGATION

ALL SHEET NUMBERS ARE LINKED IN PDF VERSION FOR QUICK NAVIGATION. THE TYPICAL DETAILS HAVE BEEN DEVELOPED WITH A NAVIGATION SYSTEM AND KEY BAR TO ASSIST THE DESIGN PROFESSIONALS WITH LINKING THE SPECIFIC BMP TO RELEVANT. DESIGN NOTES AND POSSIBLE DETAIL COMPONENTS. EXAMPLE KEY BAR:

EDGE TREATMENTS						SUBSURFACE CHECK DAMS		SUBSURFACE OUTLETS				
KEY MAP		COMPONENTS				NOTES	COMPONENTS	NOTES	COMPONENTS			
PC 1.1	PC 1.2	PC 1.3	PC 1.4	PC 1.5	PC 1.6	PC 2.1	PC 2.2	PC 3.1	PC 3.2	PC 3.3	PC 3.4	

USE ON CONSTRUCTION DOCUMENTS

DESIGN PROFESSIONALS USING THE AUTOCAD DRAWINGS **MUST REVIEW AND ADJUST THE DETAILS AND CONSTRUCTION NOTES TO ADDRESS THEIR SITE-SPECIFIC CONDITIONS**. TO ALLOW FOR SITE-SPECIFIC DESIGN ADJUSTMENTS THE TYPICAL DETAILS ARE DEVELOPED AS **"NOT FOR CONSTRUCTION"** DRAWINGS. TITLE BLOCKS ARE PROVIDED FOR DOCUMENT ORGANIZATION AND REFERENCE ONLY.

- **DO NOT** INCLUDE THE NON-ADJUSTED DETAIL WITH TITLE BLOCK WITHIN THE CONSTRUCTION DOCUMENTS.
- **DO NOT** INCLUDE NON-ADJUSTED DETAIL PLANS, SECTIONS, OR CONSTRUCTION NOTES WITHIN THE CONSTRUCTION DOCUMENTS.
- **DO NOT** REFERENCE THE GI TYPICAL DETAIL SHEET NAME AND/OR NUMBER (I.E. **BP 2.1**) AS A STANDARD DETAIL CALL-OUT WITHIN THE CDs.
- **DO NOT** EXPECT CONTRACTORS TO CONDUCT CALCULATIONS OR BE RESPONSIBLE FOR MISSING DESIGN INFORMATION.



**GREEN INFRASTRUCTURE
TYPICAL DETAILS**
SAN FRANCISCO PUBLIC UTILITIES COMMISSION

DATE
JANUARY 2023
VERSION
3.0
REVISED

USER GUIDE

DWG NO.
**GEN
0.1**

NOT FOR CONSTRUCTION - REFER TO USER GUIDE

SUMMARY OF REQUIREMENTS AND GUIDANCE FOR INFILTRATION-BASED BMPS:

REFER TO STORMWATER MANAGEMENT REQUIREMENTS APPENDIX C: CRITERIA FOR INFILTRATION - BASED BMPS FOR MORE DETAILED INFORMATION ON SITING AND DESIGN REQUIREMENTS FOR INFILTRATION-BASED BMPS.

1. STANDARD SETBACK REQUIREMENTS PER THE STORMWATER MANAGEMENT REQUIREMENTS:

SETBACK DISTANCE (FEET)	SETBACK FROM:
5	PROPERTY LINE
10	DOWNGRADIENT FROM ADJACENT FOUNDATIONS
100	UPGRADIENT FROM ADJACENT FOUNDATIONS
100	UPGRADIENT FROM GROUND SLOPES >15%
150	DRINKING WATER WELL

2. REFER TO APPENDIX C OF THE STORMWATER MANAGEMENT REQUIREMENTS FOR CONDITIONAL SETBACK REQUIREMENTS AND THE SFPUC ASSET PROTECTION STANDARDS FOR ADDITIONAL SETBACK REQUIREMENTS REGARDING WATER AND SEWER INFRASTRUCTURE.
3. MINIMUM 4-FOOT VERTICAL SEPARATION FROM BASE OF INFILTRATION GALLERY TO BEDROCK IS REQUIRED. IF A SAND LAYER IS INSTALLED FOR WATER QUALITY TREATMENT, THIS SEPARATION SHALL BE MEASURED FROM THE BASE OF THE SAND LAYER.
4. VERTICAL SEPARATION TO GROUND WATER (IF A SAND LAYER IS INSTALLED FOR WATER QUALITY TREATMENT, THIS SEPARATION SHALL BE MEASURED FROM THE BASE OF THE SAND LAYER):
- **BAYSIDE:** MINIMUM 4-FOOT VERTICAL SEPARATION FROM BASE OF INFILTRATION GALLERY TO SEASONAL HIGH GROUNDWATER TABLE IS REQUIRED FOR ALL BAYSIDE GROUNDWATER BASINS.
 - **LOBOS & WESTSIDE BASINS:** MINIMUM 4-FOOT TO 10-FOOT VERTICAL SEPARATION FROM BASE OF INFILTRATION GALLERY TO SEASONAL HIGH GROUNDWATER TABLE IS REQUIRED IN THE LOBOS AND WESTSIDE GROUNDWATER BASINS, DEPENDENT UPON SITE CHARACTERISTICS AND SFPUC APPROVAL.

SOIL TYPE GUIDANCE:

HYDROLOGIC SOIL GROUP	SOIL TYPE	CORRESPONDING UNIFIED SOIL CLASSIFICATION	DESCRIPTION
A	SAND, LOAMY SAND, OR SANDY LOAM	GW - WELL-GRADED GRAVELS, SANDY GRAVELS GP - GAP-GRADED OR UNIFORM GRAVELS, SANDY GRAVELS GM - SILTY GRAVELS, SILTY SANDY GRAVELS SW - WELL-GRADED, GRAVELLY SANDS SP - GAP-GRADED OR UNIFORM SANDS, GRAVELLY SANDS	LOW RUNOFF POTENTIAL. SOILS HAVING HIGH INFILTRATION RATES EVEN WHEN THOROUGHLY WETTED AND CONSISTING CHIEFLY OF DEEP, WELL TO EXCESSIVELY DRAINED SANDS OR GRAVELS.
B	SILT LOAM OR LOAM	SM - SILTY SANDS, SILTY GRAVELLY SANDS MH - MICACEOUS SILTS, DIATOMACEOUS SILTS, VOLCANIC ASH	SOILS HAVING MODERATE INFILTRATION RATES WHEN THOROUGHLY WETTED AND CONSISTING CHIEFLY OF MODERATELY DEEP TO DEEP, MODERATELY WELL TO WELL-DRAINED SOILS WITH MODERATELY FINE TO MODERATELY COARSE TEXTURES.
C	SANDY CLAY LOAM	ML - SILTS, VERY FINE SANDS, SILTY AND CLAYEY FINE SANDS	SOILS HAVING SLOW INFILTRATION RATES WHEN THOROUGHLY WETTED AND CONSISTING CHIEFLY OF SOILS WITH A LAYER THAT IMPEDES DOWNWARD MOVEMENT OF WATER, OR SOILS WITH MODERATELY FINE TO FINE TEXTURES.
D	CLAY LOAM, SANDY CLAY, SILTY CLAY, OR CLAY	GC - CLAYEY GRAVELS, CLAYEY SANDY GRAVELS SC - CLAYEY SANDS, CLAYEY GRAVELLY SANDS CL - LOW PLASTICITY CLAYS, SANDY OR SILTY CLAYS OL - ORGANIC SILTS AND CLAYS OF LOW PLASTICITY CH - HIGHLY PLASTIC LAYS AND SANDY CLAYS OH - ORGANIC SILTS AND CLAYS OF HIGH PLASTICITY	HIGH RUNOFF POTENTIAL. SOILS HAVING VERY SLOW INFILTRATION RATES WHEN THOROUGHLY WETTED AND CONSISTING CHIEFLY OF CLAY SOILS WITH A HIGH SWELLING POTENTIAL, SOILS WITH A PERMANENT HIGH WATER TABLE, AND SHALLOW SOILS OVER NEARLY IMPERVIOUS MATERIAL.



**GREEN INFRASTRUCTURE
TYPICAL DETAILS**
SAN FRANCISCO PUBLIC UTILITIES COMMISSION

DATE	JANUARY 2023
VERSION	3.0
REVISED	

**INFILTRATION-BASED BMP
GUIDANCE**

DWG NO.
**GEN
0.2**

PURPOSE:

PERMEABLE PAVEMENT (PAVEMENT) CONTROLS PEAK FLOWS AND VOLUMES OF STORMWATER RUNOFF VIA INFILTRATION THROUGH THE PAVEMENT SURFACE, STORAGE IN THE PAVEMENT SECTION, INFILTRATION INTO NATIVE SOIL, AND OVERFLOW THROUGH OPTIONAL SUBSURFACE OUTLETS (WHERE REQUIRED). RUNOFF IS TREATED AS IT INFILTRATES INTO UNDERLYING NATIVE SOIL. PER MS4 PERMIT, OUTFLOW FROM PERMEABLE PAVEMENT IS CONSIDERED UNTREATED.

DESIGNER NOTES & GUIDELINES:

1. THE DESIGNER MUST ADAPT PLAN, SECTION DRAWINGS, AND CALCULATE DEPTH TO ADDRESS SITE-SPECIFIC CONDITIONS.
2. ALL PAVEMENT SYSTEMS MUST BE DESIGNED BY A LICENSED ENGINEER IN ACCORDANCE WITH THE AASHTO GUIDE FOR DESIGN OF PAVEMENT STRUCTURES BASED ON SITE-SPECIFIC CONDITIONS INCLUDING TRAFFIC LOADS AND SUBGRADE CONDITIONS. PAVEMENT SECTIONS SET FORTH IN THESE TYPICAL DETAILS ARE PROVIDED TO REPRESENT THE ANTICIPATED RANGE OF DESIGN REQUIREMENTS, BASED ON "GOOD" AND "POOR" SOIL CHARACTERIZATIONS NORMALLY ENCOUNTERED IN SAN FRANCISCO. **ACTUAL SECTION DEPTHS MUST BE DETERMINED AS DESCRIBED IN GUIDELINE #3, BELOW.** SEE TABLES BELOW FOR TRAFFIC LOADING AND EFFECTIVE ROADBED SOIL RESILIENT MODULUS ASSUMPTIONS USED IN DEVELOPING THESE TYPICAL SECTIONS.
3. TRAFFIC LOADING ASSUMPTIONS:

DESIGN ASSUMPTION	MODERATE VEHICULAR	LIGHT VEHICULAR	PEDESTRIAN
EQUIVALENT SINGLE AXLE LOADS*	2,000,000	40,000	800
TRAFFIC INDEX (TI)**	10	6.5	4
* SEE AASHTO GUIDE FOR DESIGN OF PAVEMENT STRUCTURES FOR DEFINITIONS			
** SEE CALTRANS HIGHWAY DESIGN MANUAL FOR DEFINITIONS			

SUBGRADE ASSUMPTIONS:

DESIGN ASSUMPTION	GOOD SOILS	POOR SOILS
EFFECTIVE ROADBED SOIL RESILIENT MODULUS, M_R (PSI)*	6,800	3,700
CALIFORNIA R-VALUE **	33.3	15.6
DRAINAGE COEFFICIENT, m *	1.15	0.75
LAYER COEFFICIENT, a * FOR OPEN GRADED AGGREGATE BASE	0.08	
* SEE AASHTO GUIDE FOR DESIGN OF PAVEMENT STRUCTURES FOR DEFINITIONS		
** SEE CALTRANS HIGHWAY DESIGN MANUAL FOR DEFINITIONS		

4. GEOTECHNICAL EVALUATION OF SUBGRADE SOILS TO VERIFY THEIR STRUCTURAL SUITABILITY FOR PERMEABLE PAVEMENT INSTALLATIONS IS REQUIRED. INFILTRATION TESTING REQUIREMENTS ARE SUBJECT TO DIFFERENT THRESHOLDS. REFER TO SAN FRANCISCO STORMWATER MANAGEMENT REQUIREMENTS FOR GUIDANCE.
5. THE PERMEABLE PAVEMENT FACILITY MUST BE DESIGNED TO PROVIDE SUFFICIENT SUBSURFACE STORAGE IN THE PAVEMENT SECTION TO MEET PROJECT HYDROLOGIC PERFORMANCE GOALS. THE SECTION THICKNESS WILL BE A FUNCTION OF THE SUBGRADE INFILTRATION RATE (DRAINAGE COEFFICIENT), SUBGRADE SLOPE, AND THE HEIGHT AND SPACING OF SUBSURFACE CHECK DAMS. SEE **PC 2.1** AND **PC 2.2**.
6. ENTIRE PAVEMENT BASE SECTION MAY BE USED TO MEET SUBSURFACE STORAGE REQUIREMENTS.
7. SUBSURFACE STORAGE DRAWDOWN TIME (I.E. TIME FOR MAXIMUM SUBSURFACE STORAGE VOLUME TO INFILTRATE INTO SUBGRADE AFTER THE END OF A STORM) SHOULD NOT EXCEED 48 HOURS. DRAWDOWN TIME IS CALCULATED AS THE MAXIMUM SUBSURFACE PONDING DEPTH DIVIDED BY THE NATIVE SOIL INFILTRATION RATE.
8. THE DESIGNER MUST ENSURE THAT THE PAVEMENT EDGES ARE RESTRAINED AND THAT WATER IS CONTAINED IN THE PAVEMENT SECTION AS NEEDED TO PROTECT ADJACENT PAVEMENT SECTIONS OR STRUCTURES. SEE EDGE TREATMENTS (**PC 1.1** THROUGH **PC 1.6**) FOR GUIDANCE ON DESIGN OF THESE COMPONENTS.
9. THE DESIGNER MUST EVALUATE UTILITY SURVEYS FOR POTENTIAL UTILITY CROSSINGS OR CONFLICTS. REFER TO **GC 2.1 - GC 2.12** FOR UTILITY CROSSING DETAILS AND **GC 3.1 - GC 3.4** FOR UTILITY CROSSING CONFLICT DETAILS.

RELATED COMPONENTS		
EDGE TREATMENTS:	PC 1.1	PC 1.6
CHECK DAMS:	PC 2.1	PC 2.2
OVERFLOWS:	PC 3.1	PC 3.3
LINERS:	GC 1.1	GC 1.2
UTILITY CROSSINGS:	GC 2.1	GC 2.12
UTILITY CONFLICTS:	GC 3.1	GC 3.4
OBSERVATION PORTS:	GC 4.1	GC 4.3
CLEANOUTS:	GC 5.1	

RELATED SPECIFICATIONS	CSI NO.
PERMEABLE/POROUS UNIT PAVERS: - PERMEABLE /POROUS UNIT PAVERS - JOINT FILLER AGGREGATE - PAVEMENT BASE - EDGE RESTRAINTS - GEOTEXTILE FOR SOIL SEPARATION	32 14 43
PERVIOUS CONCRETE PAVEMENT: - PERVIOUS CONCRETE - PAVEMENT BASE - GEOTEXTILE FOR SOIL SEPARATION	32 13 43
POROUS ASPHALT PAVEMENT: - POROUS ASPHALT - PAVEMENT BASE - GEOTEXTILE FOR SOIL SEPARATION	32 12 43

NOTES		KEY MAP	SECTIONS		
PP 1.1	PP 1.2	PP 1.3	PP 2.1	PP 3.1	PP 4.1



**GREEN INFRASTRUCTURE
TYPICAL DETAILS**
SAN FRANCISCO PUBLIC UTILITIES COMMISSION

DATE	JANUARY 2023
VERSION	3.0
REVISED	

**PERMEABLE PAVEMENT
DESIGNER NOTES (1 OF 2)**

DWG NO.
**PP
1.1**

NOT FOR CONSTRUCTION - REFER TO USER GUIDE

LAYOUT REQUIREMENTS:

- ALL PERMEABLE PAVEMENT APPLICATIONS SHALL CONFORM TO THE CURRENT CITY OF SAN FRANCISCO PUBLIC WORKS PERMEABLE PAVEMENT DIRECTORS ORDER [PENDING COMPLETION]. THE DESIGN MUST COMPLY WITH SAN FRANCISCO PUBLIC WORKS STANDARD ACCESSIBILITY REQUIREMENTS.
- PERVIOUS PAVEMENT SHOULD BE DESIGNED TO PREVENT STORMWATER RUN-ON WHENEVER POSSIBLE. THE RECOMMENDED AND ALLOWED CONTRIBUTING RUN-ON FROM AN IMPERVIOUS SURFACE TO A PERVIOUS PAVEMENT IS PROVIDED IN THE FOLLOWING TABLE:

WEARING COURSE	INTERLOCKING GAP SIZE		RECOMMENDED RUN-ON RATIO	MAXIMUM ALLOWED RUN-ON RATIO ^c	
	(INCH)	(mm)		PUBLIC ROW (ROADWAY & PARKING LANE) AND PRIVATE DRIVEWAY	PUBLIC ROW SIDEWALK AND PRIVATE HARDSCAPE (PEDESTRIAN)
PERVIOUS CONCRETE & POROUS ASPHALT			NONE	2:1	3:1
PERMEABLE UNIT PAVERS [PARCEL ONLY] ^a	1/2" GAPS	12	NONE	2:1	3:1
PERMEABLE UNIT PAVERS [ROW OR PARCEL] ^{a,b}	≥ 3/8" GAPS	10	NONE	1.5:1	2:1
PERMEABLE UNIT PAVERS [ROW OR PARCEL] ^{a,b}	≥ 1/4" GAPS	6-8	NONE	0.5:1	1:1
POROUS PAVERS	-	-	NONE	NONE	NONE

NOTES:

- PERMEABLE UNIT PAVERS INSTALLED IN AREAS OF VEHICULAR LOADING SHALL HAVE INTERLOCKING SPACERS INTEGRATED INTO EACH UNIT TO INCREASE STABILITY AND MAINTAIN SPECIFIED GAP WIDTH.
- PERMEABLE UNIT PAVERS INSTALLED IN AREAS OF PEDESTRIAN LOADING ARE RECOMMENDED TO HAVE INTERLOCKING SPACERS, HOWEVER MAY SPECIFY STRUCTURAL PAVER SPACERS (I.E. TILE SPACERS NOT ALLOWED). SFPUC TO REVIEW AND APPROVE SPECIFIED SPACERS.
- THE DESIGNER SHALL INFORM OWNER OF NEED TO INCREASE SURFACE CLEANING INTERVALS ASSOCIATED WITH THESE RUN-ON RATIOS.

- WHEN DESIGNED TO ACCEPT RUN-ON FROM OTHER CATCHMENT AREAS, PERMEABLE PAVEMENT AREAS MUST BE PROTECTED FROM SEDIMENTATION WHICH CAN CAUSE CLOGGING AND DIMINISHED FACILITY PERFORMANCE. THE FOLLOWING REQUIREMENTS APPLY FOR RUN-ON CONTRIBUTIONS:
 - RUN-ON FROM UNSTABILIZED LANDSCAPE AREAS OR OTHER HIGH POLLUTANT AREAS (I.E. MORE POLLUTANT DISCHARGE THAN PARKING LOTS AND ROADWAYS) IS PROHIBITED. ANY LANDSCAPED AREAS WHICH DRAIN TO A PERVIOUS PAVEMENT SURFACE MUST BE FULLY MULCHED AND GRADED TO PREVENT SEDIMENT LADEN RUN-OFF FROM DEVELOPING. ANY TURF AREAS MUST BE ESTABLISHED FROM SOD.
 - CONCENTRATED RUN-ON (E.G., DIRECT DISCHARGE FROM A DOWNSPOUT) SHOULD BE DISPERSED PRIOR TO DISCHARGE TO A PERMEABLE PAVEMENT FACILITY. ACCEPTABLE METHODS INCLUDE SHEET FLOW OR SUBSURFACE DELIVERY TO THE STORAGE RESERVOIR. IF SUBSURFACE DELIVERY IS USED, (I.E. ACTS AS INFILTRATION GALLERY) PRETREATMENT AND FLOW DISTRIBUTION ARE REQUIRED, SEE IG1.1 - IG5.1.
- WEARING COURSE SHALL BE SET FLUSH (± 3/16 INCH) WITH ADJACENT WALKING SURFACES.

- WEARING COURSE SHALL HAVE A MINIMUM SURFACE SLOPE OF 0.5% TO ALLOW FOR SURFACE OVERFLOW AND A MAXIMUM SURFACE SLOPE AS LISTED BELOW:
 - POROUS ASPHALT SURFACE: 5 PERCENT SLOPE
 - PERVIOUS CONCRETE SURFACE: 10 PERCENT SLOPE
 - PERMEABLE UNIT PAVERS: 10 PERCENT SLOPE (OR LESS PER MANUFACTURER'S RECOMMENDATION)

- WHILE THERE IS NO MAXIMUM SLOPE FOR THE SUBGRADE UNDER THE PERMEABLE PAVEMENT COURSES, THERE MAY BE ENGINEERING CHALLENGES ASSOCIATED WITH SUBSURFACE CHECK DAM REQUIREMENTS ON SUBGRADE SLOPES EXCEEDING 5%. SEE SUBSURFACE CHECK DAMS (PC 2.1 AND PC 2.2).
- PAVER GAPS MUST HAVE AN OPEN AREA RATIO GREATER THAN 5%. TO MAXIMIZE LONG-TERM PERFORMANCE AND MINIMIZE CLOGGING, THE DESIGNER SHALL SELECT PERMEABLE UNIT PAVERS WITH HIGHER OPEN AREA RATIO WHEN LOCATED IN AREAS WITH POTENTIAL FOR SEDIMENT RUN-ON AND CLOGGING.
- REFER TO **SHEET GEN 0.2** AND APPENDIX C OF THE STORMWATER MANAGEMENT REQUIREMENTS FOR MORE DETAILED INFORMATION ON SITING AND DESIGN REQUIREMENTS FOR INFILTRATION-BASED BMPS.

DESIGNER CHECKLIST (MUST SPECIFY, AS APPLICABLE):

- PERMEABLE PAVEMENT SPECIFICATIONS AND/OR PAVER TYPE AND GAP WIDTH
- PERMEABLE PAVEMENT WIDTH AND LENGTH
- ELEVATIONS AND CONTROL POINTS AT EVERY CORNER OR POINT OF TANGENCY
- THICKNESS OF EACH LAYER IN THE PAVEMENT SECTION
- JOINT SPACING AND TYPE
- SUBGRADE SLOPE
- STRUCTURAL PAVER SPACER MODEL, HEIGHT, AND WIDTH (PEDESTRIAN ONLY)
- SUBSURFACE CHECK DAM SPACING, HEIGHT, AND TYPE
- SUBSURFACE OVERFLOW STRUCTURE
- ELEVATIONS OF EACH PIPE INLET AND OUTLET INVERT
- TYPE AND DESIGN OF PERMEABLE PAVEMENT COMPONENTS (E.G., OUTLETS, UNDERDRAINS, etc.)
- DETAIL OF PAVEMENT EDGE SHOWING STRUCTURAL SUPPORT AND TRANSITION TO ADJACENT SURFACE

NOTES		KEY MAP	SECTIONS		
PP 1.1	PP 1.2	PP 1.3	PP 2.1	PP 3.1	PP 4.1



**GREEN INFRASTRUCTURE
TYPICAL DETAILS**
SAN FRANCISCO PUBLIC UTILITIES COMMISSION

DATE	JANUARY 2023
VERSION	3.0
REVISED	

**PERMEABLE PAVEMENT
DESIGNER NOTES (2 OF 2)**

DWG NO.
**PP
1.2**

NOT FOR CONSTRUCTION - REFER TO USER GUIDE

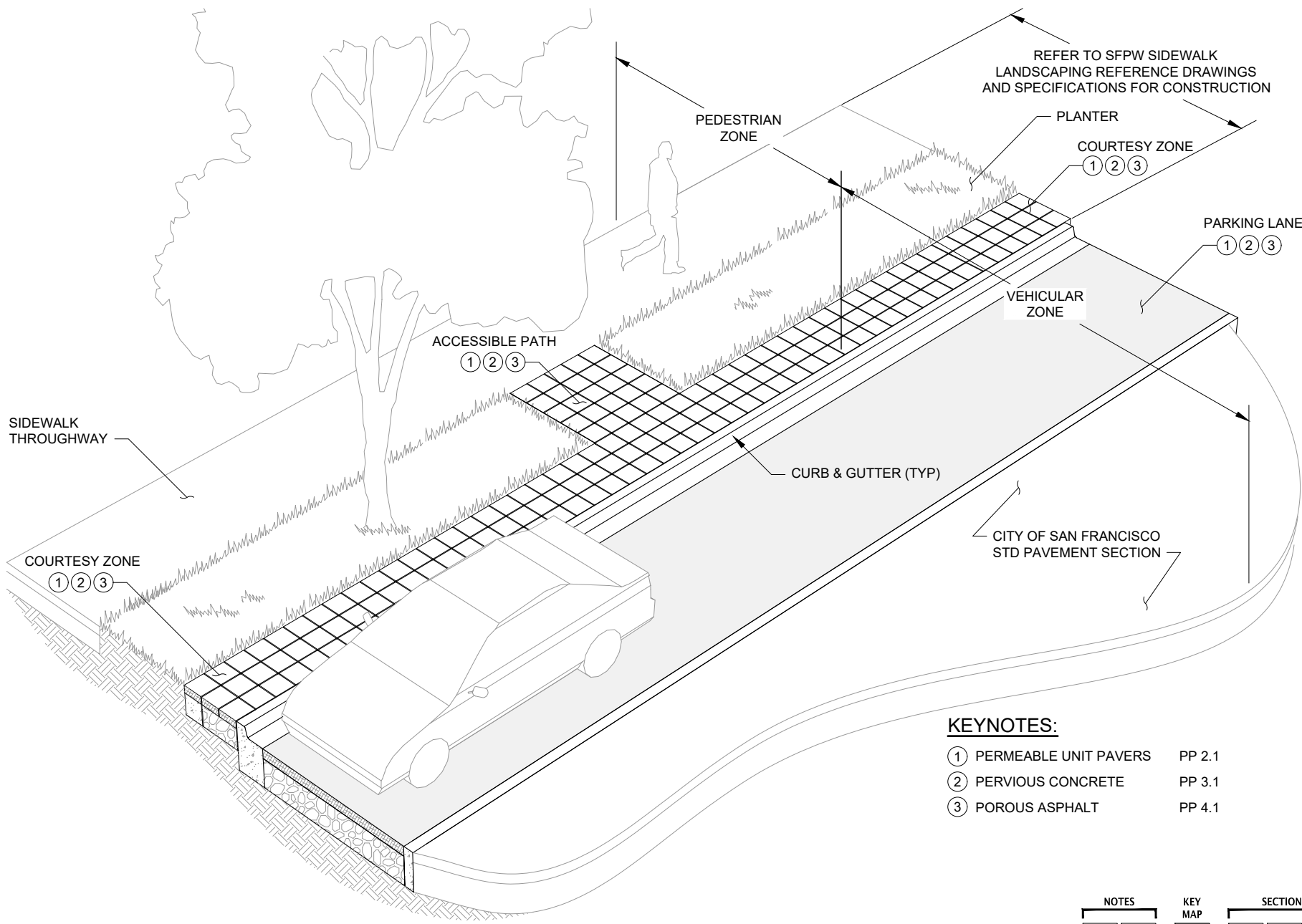

- KEYNOTES:**
- ① PERMEABLE UNIT PAVERS PP 2.1
 - ② PERVIOUS CONCRETE PP 3.1
 - ③ POROUS ASPHALT PP 4.1

NOTES		KEY MAP	SECTIONS		
PP 1.1	PP 1.2	PP 1.3	PP 2.1	PP 3.1	PP 4.1

NOT FOR CONSTRUCTION - REFER TO USER GUIDE



**GREEN INFRASTRUCTURE
TYPICAL DETAILS**
SAN FRANCISCO PUBLIC UTILITIES COMMISSION

DATE	JANUARY 2023
VERSION	3.0
REVISED	

**PERMEABLE PAVEMENT
KEY MAP**

DWG NO.
**PP
1.3**

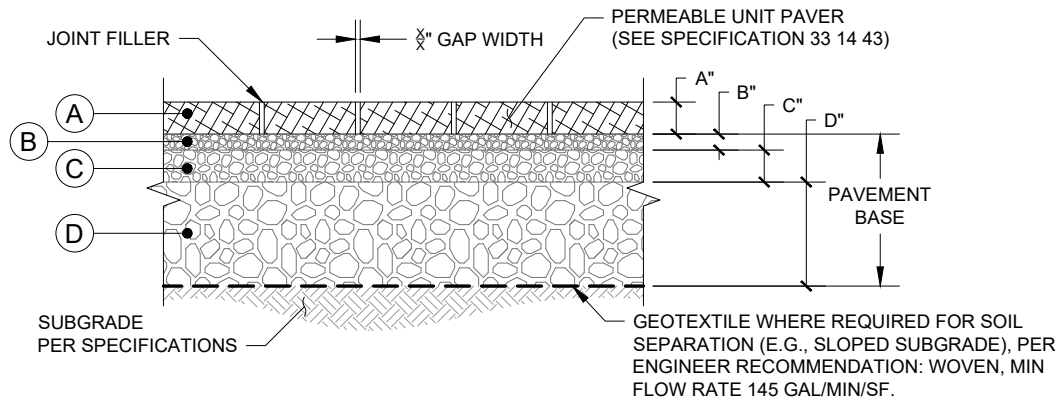

PERMEABLE UNIT PAVERS (1)

MINIMUM MATERIAL THICKNESS (IN):

LAYER	MATERIAL TYPE*	MODERATE VEHICULAR		LIGHT VEHICULAR		PEDESTRIAN	
		GOOD SOILS**	POOR SOILS**	GOOD SOILS**	POOR SOILS**	GOOD SOILS**	POOR SOILS**
(A)	PERMEABLE UNIT PAVERS	3 1/8	3 1/8	3 1/8	3 1/8	3 1/8	3 1/8
(B)	LEVELING COURSE ASTM NO. 8	2	2	2	2	2	2
(C)	BASE COURSE ASTM NO. 57	6	6	6	4	4	4
(D)	RESERVOIR COURSE ASTM NO. 2, 3, OR 57	22	28	-	10	-	-

* MATERIAL FINER THAN NO. 100 SIEVE SHALL NOT EXCEED 2 PERCENT FOR ANY AGGREGATE LAYER (LICENSED PROFESSIONAL TO SELECT AGGREGATE).

** "GOOD" AND "POOR" SOIL CLASSIFICATIONS BASED ON AASHTO GUIDE FOR DESIGN OF PAVEMENT STRUCTURES. SEE DESIGNER NOTES FOR SUBGRADE ASSUMPTIONS. (LICENSED PROFESSIONAL MUST CALCULATE REQUIRED DEPTH BASED ON SITE CONDITIONS).

TYPICAL JOINT FILLER AGGREGATE SIZE:

GAP WIDTH		JOINT FILLER AGGREGATE*
(INCH)	(mm)	
3/8 OR 1/2	10 OR 12	ASTM NO. 8 OR 89
1/4	6-8	ASTM NO. 9

* PROVIDED FOR REFERENCE ONLY, FOLLOW MANUFACTURER'S RECOMMENDATIONS

FOR POROUS PAVERS ONLY: USE ASTM #10. ASTM #20 SAND NOT ALLOWED (PER MANUFACTURER'S RECOMMENDATION).

CONSTRUCTION NOTES:

- SEE PERMEABLE/POROUS UNIT PAVER SPECIFICATIONS FOR WEARING COURSE, PAVEMENT BASE, SUBGRADE, AND OTHER REQUIREMENTS FOR PERMEABLE/POROUS UNIT PAVER FACILITIES.
- MINIMUM UTILITY SETBACKS AND PROTECTION MEASURES MUST CONFORM TO CURRENT SFPUC ASSET PROTECTION STANDARDS AND OTHER UTILITY PROVIDER REQUIREMENTS. COORDINATE WITH ENGINEER IN THE EVENT OF UTILITY CROSSINGS AND UTILITY CONFLICTS.

NOTES		KEY MAP	SECTIONS		
PP 1.1	PP 1.2	PP 1.3	PP 2.1	PP 3.1	PP 4.1



**GREEN INFRASTRUCTURE
TYPICAL DETAILS**
SAN FRANCISCO PUBLIC UTILITIES COMMISSION

DATE	JANUARY 2023
VERSION	3.0
REVISED	

**PERMEABLE PAVEMENT
MATERIAL SECTIONS
PERMEABLE UNIT PAVERS**

DWG. NO.
**PP
2.1**

NOT FOR CONSTRUCTION - REFER TO USER GUIDE

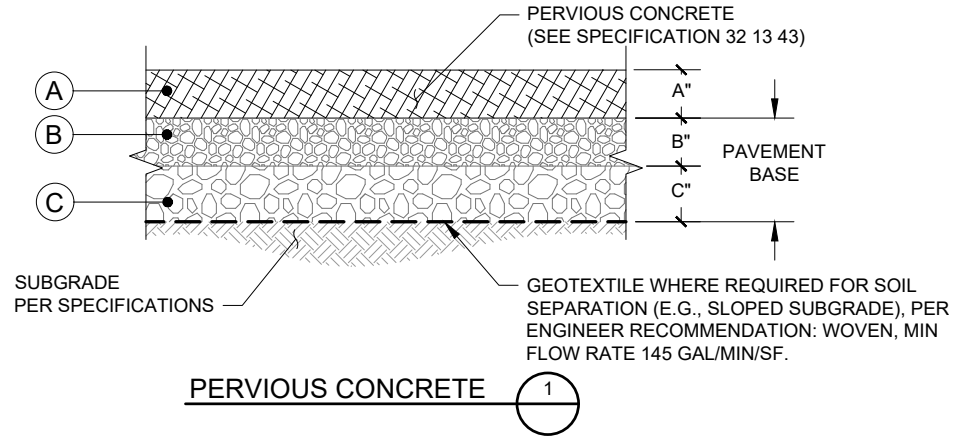

MINIMUM MATERIAL THICKNESS (IN):

LAYER	MATERIAL TYPE*	MODERATE VEHICULAR		LIGHT VEHICULAR		PEDESTRIAN	
		GOOD SOILS**	POOR SOILS**	GOOD SOILS**	POOR SOILS**	GOOD SOILS**	POOR SOILS**
(A)	PERVIOUS CONCRETE	9	9.5	6.5	7	4.5	5
(B)	BASE COURSE ASTM NO. 3 OR 57	6	6	6	6	6	6
(C)	OPTIONAL RESERVOIR COURSE ASTM NO. 2, 3, OR 57	-	-	-	-	-	-

* MATERIAL FINER THAN NO. 100 SIEVE SHALL NOT EXCEED 2 PERCENT FOR ANY AGGREGATE LAYER (LICENSED PROFESSIONAL TO SELECT AGGREGATE).

** "GOOD" AND "POOR" SOIL CLASSIFICATIONS BASED ON AASHTO GUIDE FOR DESIGN OF PAVEMENT STRUCTURES. SEE DESIGNER NOTES FOR SUBGRADE ASSUMPTIONS. (LICENSED PROFESSIONAL MUST CALCULATE REQUIRED DEPTH BASED ON SITE CONDITIONS).

CONSTRUCTION NOTES:

1. SEE PERVIOUS CONCRETE SPECIFICATIONS FOR WEARING COURSE, PAVEMENT BASE, SUBGRADE, AND OTHER REQUIREMENTS FOR PERVIOUS CONCRETE FACILITIES.
2. MINIMUM UTILITY SETBACKS AND PROTECTION MEASURES MUST CONFORM TO CURRENT SFPUC ASSET PROTECTION STANDARDS AND OTHER UTILITY PROVIDER REQUIREMENTS. COORDINATE WITH ENGINEER IN THE EVENT OF UTILITY CROSSINGS AND UTILITY CONFLICTS.

NOT FOR CONSTRUCTION - REFER TO USER GUIDE

NOTES		KEY MAP	SECTIONS		
PP 1.1	PP 1.2	PP 1.3	PP 2.1	PP 3.1	PP 4.1



**GREEN INFRASTRUCTURE
TYPICAL DETAILS**
SAN FRANCISCO PUBLIC UTILITIES COMMISSION

DATE	JANUARY 2023
VERSION	3.0
REVISED	

**PERMEABLE PAVEMENT
MATERIAL SECTIONS
PERVIOUS CONCRETE**

DWG NO.
**PP
3.1**

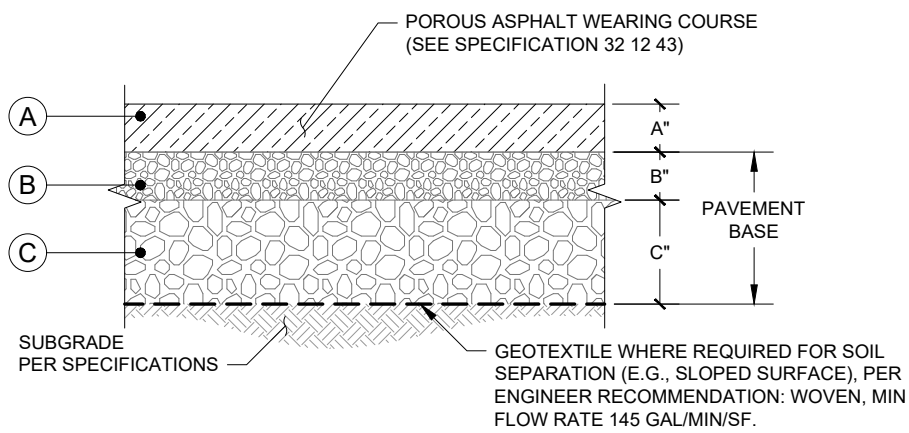

POROUS ASPHALT 1

MINIMUM MATERIAL THICKNESS (IN):

LAYER	MATERIAL TYPE*	MODERATE VEHICULAR		LIGHT VEHICULAR		PEDESTRIAN	
		GOOD SOILS**	POOR SOILS**	GOOD SOILS**	POOR SOILS**	GOOD SOILS**	POOR SOILS**
(A)	POROUS ASPHALT	6	8	4	4	3	4
(B)	BASE COURSE ASTM NO. 57	6	6	5	4	6	4
(C)	RESERVOIR COURSE ASTM NO. 2, 3, OR 57	10	19	-	11	-	8

* MATERIAL FINER THAN NO. 100 SIEVE SHALL NOT EXCEED 2 PERCENT FOR ANY AGGREGATE LAYER (LICENSED PROFESSIONAL TO SELECT AGGREGATE).

** "GOOD" AND "POOR" SOIL CLASSIFICATIONS BASED ON AASHTO GUIDE FOR DESIGN OF PAVEMENT STRUCTURES. SEE DESIGNER NOTES FOR SUBGRADE ASSUMPTIONS. (LICENSED PROFESSIONAL MUST CALCULATE REQUIRED DEPTH BASED ON SITE CONDITIONS).

CONSTRUCTION NOTES:

1. SEE POROUS ASPHALT SPECIFICATIONS FOR WEARING COURSE, PAVEMENT BASE, SUBGRADE, AND OTHER REQUIREMENTS FOR POROUS ASPHALT FACILITIES.
2. MINIMUM UTILITY SETBACKS AND PROTECTION MEASURES MUST CONFORM TO CURRENT SFPUC ASSET PROTECTION STANDARDS AND OTHER UTILITY PROVIDER REQUIREMENTS. COORDINATE WITH ENGINEER IN THE EVENT OF UTILITY CROSSINGS AND UTILITY CONFLICTS.

NOTES		KEY MAP	SECTIONS		
PP 1.1	PP 1.2	PP 1.3	PP 2.1	PP 3.1	PP 4.1



**GREEN INFRASTRUCTURE
TYPICAL DETAILS**
SAN FRANCISCO PUBLIC UTILITIES COMMISSION

DATE	JANUARY 2023
VERSION	3.0
REVISED	

**PERMEABLE PAVEMENT
MATERIAL SECTIONS
POROUS ASPHALT**

DWC NO.
**PP
4.1**

PURPOSE:

EDGE TREATMENTS ARE USED TO STABILIZE THE EDGE OF THE PERMEABLE PAVEMENT AND CONTAIN WATER WITHIN THE PERMEABLE PAVEMENT SECTION.

DESIGNER NOTES & GUIDELINES:

1. THE DESIGNER MUST ADAPT PLAN AND SECTION DRAWINGS TO ADDRESS SITE-SPECIFIC CONDITIONS.
2. ALL EDGE TREATMENT SYSTEMS MUST BE DESIGNED BY A LICENSED ENGINEER BASED ON SITE SPECIFIC CONDITIONS.
3. MINIMUM EDGE TREATMENT EMBEDMENT KEY DEPTHS ARE SPECIFIED TO PREVENT LATERAL SEEPAGE UNDER THE EDGE TREATMENT AND INTO ADJACENT PAVEMENT SECTIONS. DEEPER EMBEDMENT MAY BE REQUIRED UNDER SOME CONDITIONS.
4. FOR DEEP PAVEMENT SECTIONS, EDGE TREATMENT NOT REQUIRED TO EXTEND MORE THAN 12 INCHES BELOW WEARING COURSE PROVIDED REQUIREMENTS AT INTERFACE WITH IMPERMEABLE PAVEMENTS ARE SATISFIED.
5. USE THE EDGE TREATMENT KEY MAP ON **PC 1.2** AND CURRENT CITY OF SAN FRANCISCO PUBLIC WORKS PERMEABLE PAVEMENT DIRECTORS ORDER [PENDING COMPLETION] TO IDENTIFY WHERE EACH TYPE OF EDGE TREATMENT IS REQUIRED OR ALLOWED.
6. UNDERDRAIN LENGTHS SHALL BE SIZED FOR SUFFICIENT CAPACITY TO CONVEY THE PEAK FLOW TO THE BMP. THIS LENGTH SHALL BE BASED ON A CAPACITY OF 0.0047 CFS/LF.

DESIGNER CHECKLIST (MUST SPECIFY, AS APPLICABLE):

- EDGE TREATMENT TYPE AND MATERIAL
- EDGE TREATMENT WIDTH AND HEIGHT
- EMBEDMENT KEY DEPTH IF DIFFERENT THAN THE PROVIDED MINIMUMS
- MINIMUM UNDERDRAIN LENGTH TO CONVEY PEAK FLOW TO BMP

NOT FOR CONSTRUCTION - REFER TO USER GUIDE

EDGE TREATMENTS						SUBSURFACE CHECK DAMS		SUBSURFACE OUTLETS				
NOTES	KEY MAP	APPLICATIONS				NOTES	COMPONENTS	NOTES	COMPONENTS			
PC 1.1	PC 1.2	PC 1.3	PC 1.4	PC 1.5	PC 1.6	PC 2.1	PC 2.2	PC 3.1	PC 3.2	PC 3.3	PC 3.4	



**GREEN INFRASTRUCTURE
TYPICAL DETAILS**
 SAN FRANCISCO PUBLIC UTILITIES COMMISSION

DATE	JANUARY 2023
VERSION	3.0
REVISED	

PAVEMENT COMPONENTS
 EDGE TREATMENT
 DESIGNER NOTES

DWG NO.
**PC
1.1**

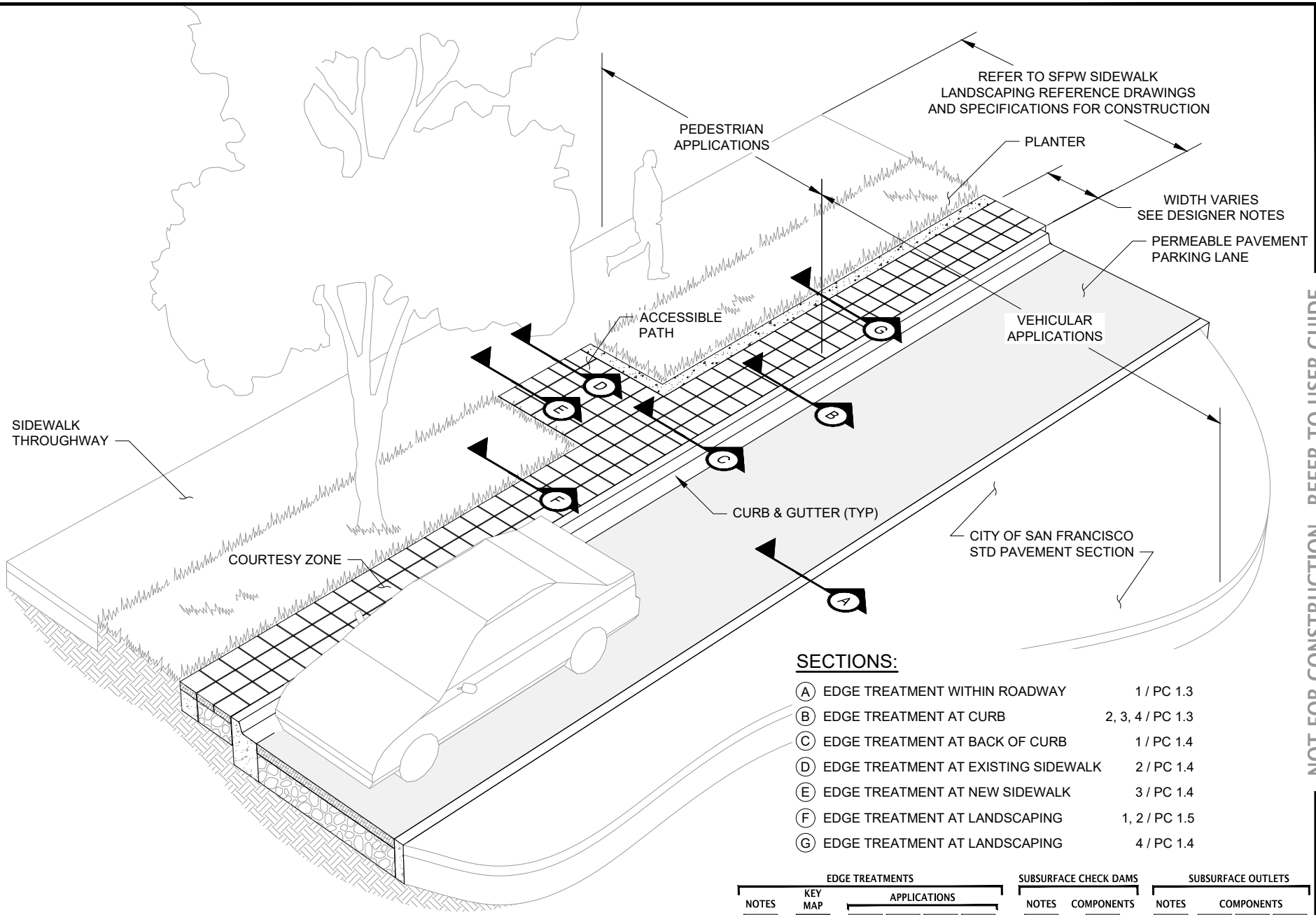

SECTIONS:

- (A) EDGE TREATMENT WITHIN ROADWAY 1 / PC 1.3
- (B) EDGE TREATMENT AT CURB 2, 3, 4 / PC 1.3
- (C) EDGE TREATMENT AT BACK OF CURB 1 / PC 1.4
- (D) EDGE TREATMENT AT EXISTING SIDEWALK 2 / PC 1.4
- (E) EDGE TREATMENT AT NEW SIDEWALK 3 / PC 1.4
- (F) EDGE TREATMENT AT LANDSCAPING 1, 2 / PC 1.5
- (G) EDGE TREATMENT AT LANDSCAPING 4 / PC 1.4

EDGE TREATMENTS						SUBSURFACE CHECK DAMS		SUBSURFACE OUTLETS			
NOTES	KEY MAP	APPLICATIONS				NOTES	COMPONENTS	NOTES	COMPONENTS		
PC 1.1	PC 1.2	PC 1.3	PC 1.4	PC 1.5	PC 1.6	PC 2.1	PC 2.2	PC 3.1	PC 3.2	PC 3.3	PC 3.4

NOT FOR CONSTRUCTION - REFER TO USER GUIDE



**GREEN INFRASTRUCTURE
TYPICAL DETAILS**
SAN FRANCISCO PUBLIC UTILITIES COMMISSION

DATE	JANUARY 2023
VERSION	3.0
REVISED	

**PAVEMENT COMPONENTS
EDGE TREATMENT
KEY MAP**

DWG. NO.
**PC
1.2**

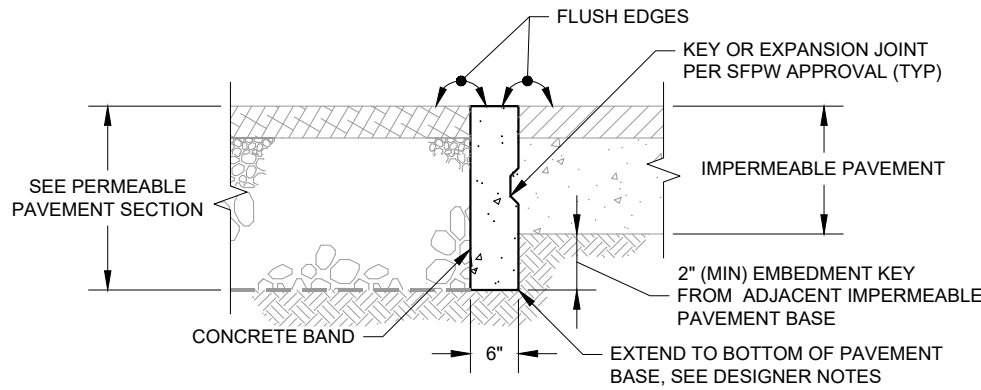

CONCRETE BAND WITHIN PAVED AREA ①

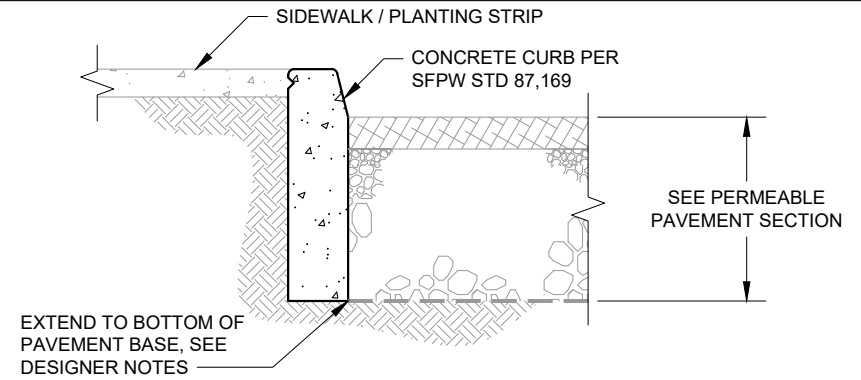

DEEPEMED STANDARD CURB ②

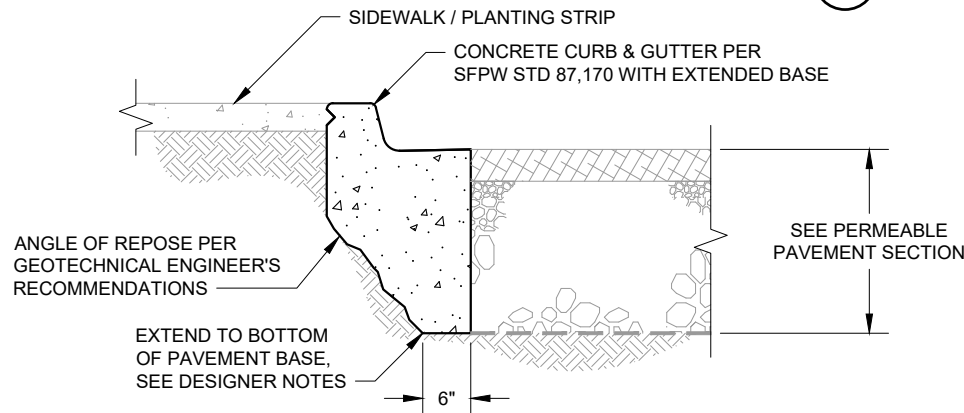

DEEPEMED STANDARD CURB AND GUTTER ③

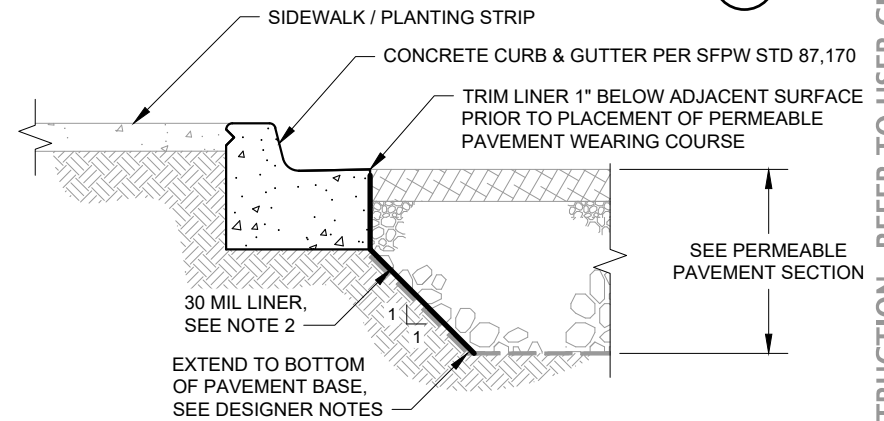

IMPERMEABLE LINER AT STANDARD CURB AND GUTTER ④

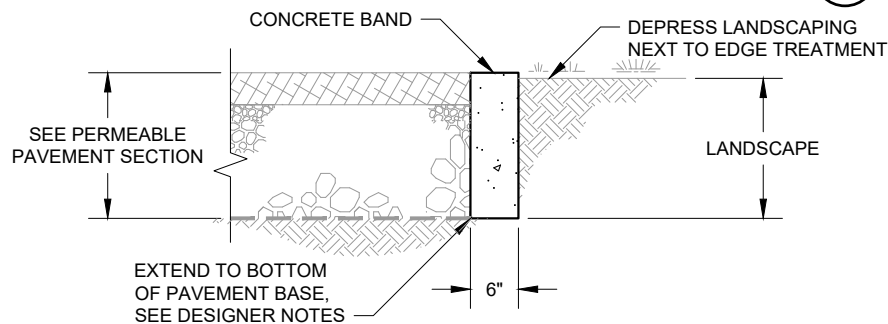

CONCRETE BAND AT LANDSCAPE ⑤

CONSTRUCTION NOTES:

1. ALL MATERIAL AND WORKMANSHIP FOR EDGE TREATMENTS SHALL CONFORM TO SAN FRANCISCO STANDARD SPECIFICATIONS AND APPLICABLE CODES PER SAN FRANCISCO DBI AND PUBLIC WORKS.
2. LINER SHALL BE HDPE CONFORMING TO GEOSYNTHETIC RESEARCH INSTITUTE (GRI) GM13 OR LLDPE CONFORMING TO GRI GM 17.

EDGE TREATMENTS						SUBSURFACE CHECK DAMS		SUBSURFACE OUTLETS			
NOTES	KEY MAP	APPLICATIONS				NOTES	COMPONENTS	NOTES	COMPONENTS		
PC 1.1	PC 1.2	PC 1.3	PC 1.4	PC 1.5	PC 1.6	PC 2.1	PC 2.2	PC 3.1	PC 3.2	PC 3.3	PC 3.4



**GREEN INFRASTRUCTURE
TYPICAL DETAILS**
SAN FRANCISCO PUBLIC UTILITIES COMMISSION

DATE
JANUARY 2023
VERSION
3.0
REVISED

PAVEMENT COMPONENTS
EDGE TREATMENTS
VEHICULAR APPLICATIONS

DWG NO.
PC 1.3

NOT FOR CONSTRUCTION - REFER TO USER GUIDE

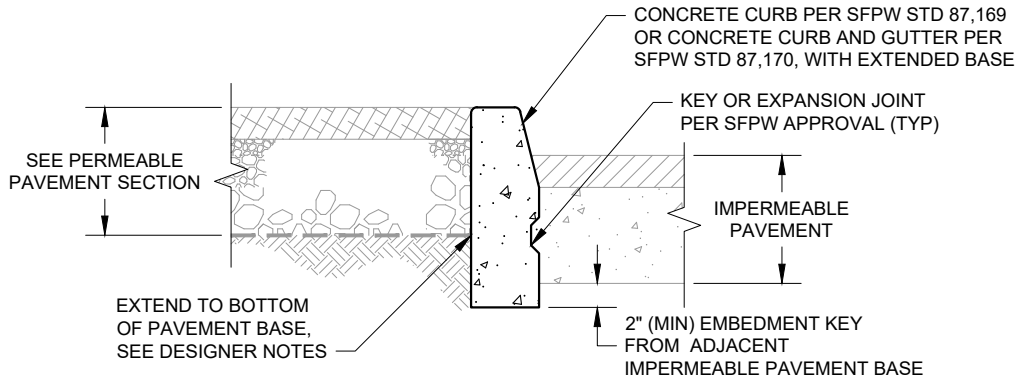

DEEPENED STANDARD CURB / CURB AND GUTTER ①

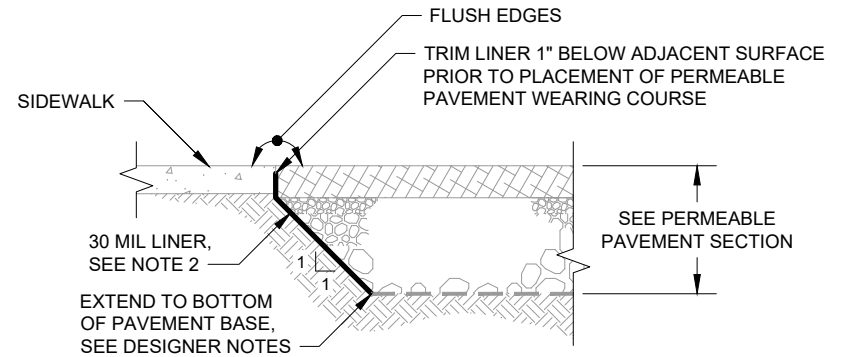

IMPERMEABLE LINER AT EXISTING SIDEWALK ②

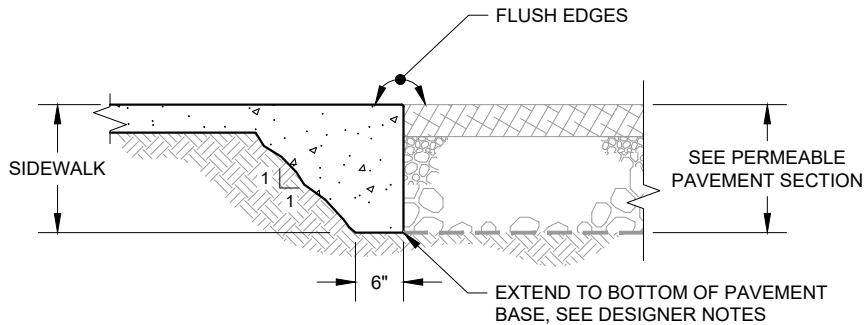

THICKENED EDGE AT NEW SIDEWALK ③

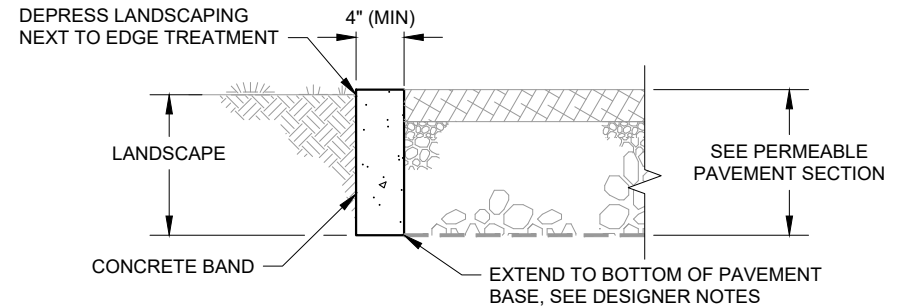

CONCRETE BAND AT LANDSCAPE ④

CONSTRUCTION NOTES:

1. ALL MATERIAL AND WORKMANSHIP FOR EDGE TREATMENTS SHALL CONFORM TO SAN FRANCISCO STANDARD SPECIFICATIONS AND APPLICABLE CODES PER SAN FRANCISCO DBI AND PUBLIC WORKS.
2. LINER SHALL BE HDPE CONFORMING TO GEOSYNTHETIC RESEARCH INSTITUTE (GRI) GM13 OR LLDPE CONFORMING TO GRI GM 17.

EDGE TREATMENTS						SUBSURFACE CHECK DAMS		SUBSURFACE OUTLETS			
NOTES	KEY MAP	APPLICATIONS				NOTES	COMPONENTS	NOTES	COMPONENTS		
PC	PC	PC	PC	PC	PC	PC	PC	PC	PC	PC	PC
1.1	1.2	1.3	1.4	1.5	1.6	2.1	2.2	3.1	3.2	3.3	3.4



**GREEN INFRASTRUCTURE
TYPICAL DETAILS**

SAN FRANCISCO PUBLIC UTILITIES COMMISSION

DATE
JANUARY 2023
VERSION
3.0
REVISED

**PAVEMENT COMPONENTS
EDGE TREATMENTS
PEDESTRIAN APPLICATIONS (1 OF 2)**

DWG NO.
**PC
1.4**

NOT FOR CONSTRUCTION - REFER TO USER GUIDE

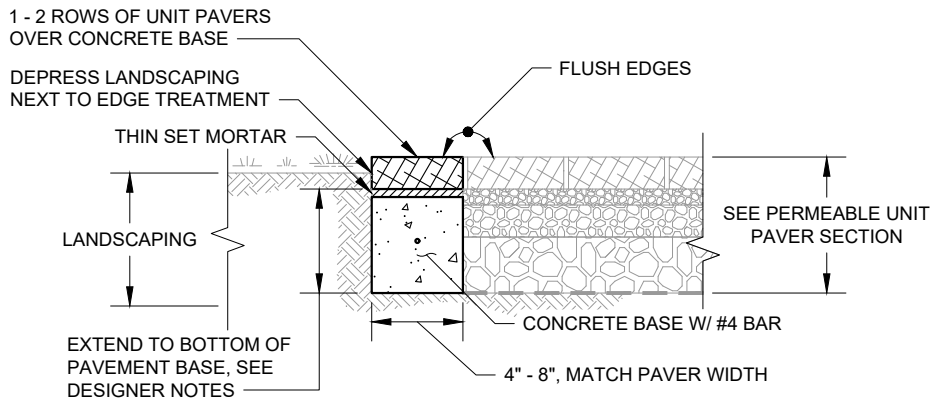

MORTARED PAVER AT LANDSCAPING ①

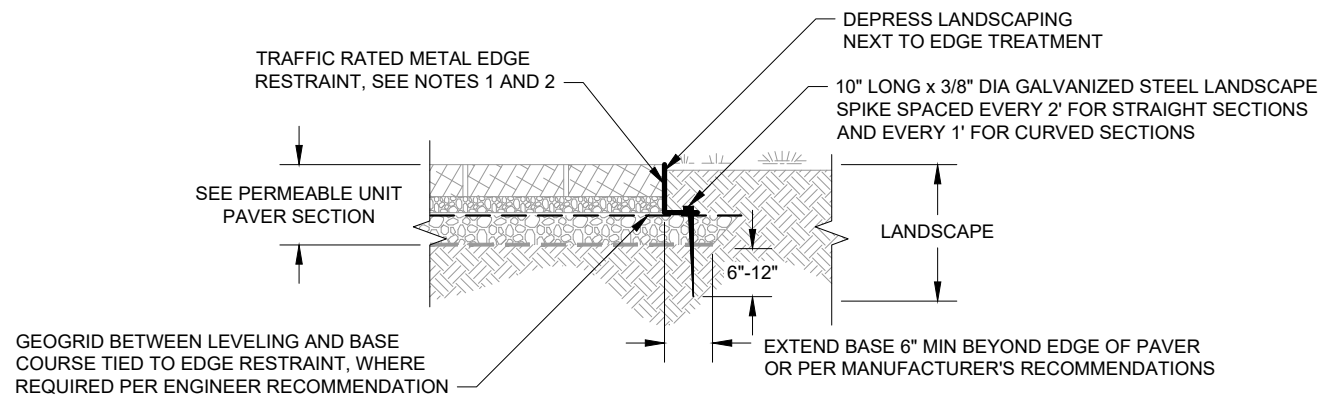

METAL PAVER EDGE AT LANDSCAPING ②

CONSTRUCTION NOTES:

1. ALL MATERIAL AND WORKMANSHIP FOR EDGE TREATMENTS SHALL CONFORM TO SAN FRANCISCO STANDARD SPECIFICATIONS AND APPLICABLE CODES PER SAN FRANCISCO DBI AND PUBLIC WORKS.
2. SIZE METAL EDGE RESTRAINT DEPTH TO 1/2" MAXIMUM BELOW TOP OF PAVER.
3. USE IN RIGHT OF WAY: MUST USE STEEL ANGLE IRON EDGE RESTRAINT. COORDINATE WITH SFPW.

EDGE TREATMENTS						SUBSURFACE CHECK DAMS		SUBSURFACE OUTLETS				
NOTES	KEY MAP	APPLICATIONS				NOTES	COMPONENTS	NOTES	COMPONENTS			
PC	PC	PC	PC	PC	PC	PC	PC	PC	PC	PC	PC	PC
1.1	1.2	1.3	1.4	1.5	1.6	2.1	2.2	3.1	3.2	3.3	3.4	



**GREEN INFRASTRUCTURE
TYPICAL DETAILS**
SAN FRANCISCO PUBLIC UTILITIES COMMISSION

DATE	JANUARY 2023
VERSION	3.0
REVISED	

PAVEMENT COMPONENTS
EDGE TREATMENTS
PEDESTRIAN APPLICATIONS (2 OF 2)

DWG NO.
**PC
1.5**

NOT FOR CONSTRUCTION - REFER TO USER GUIDE

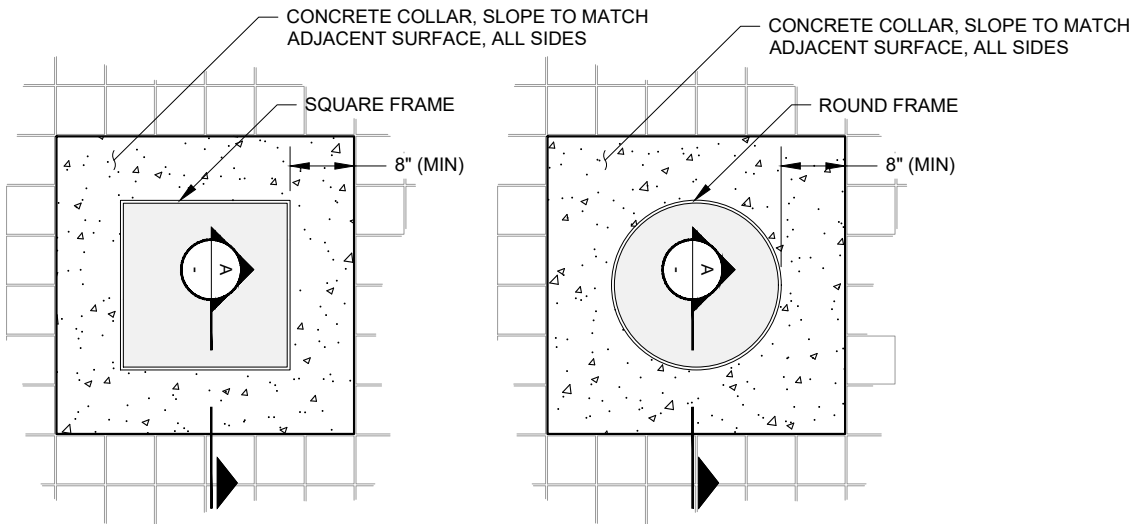

PLAN - SQUARE FRAME

PLAN - ROUND FRAME

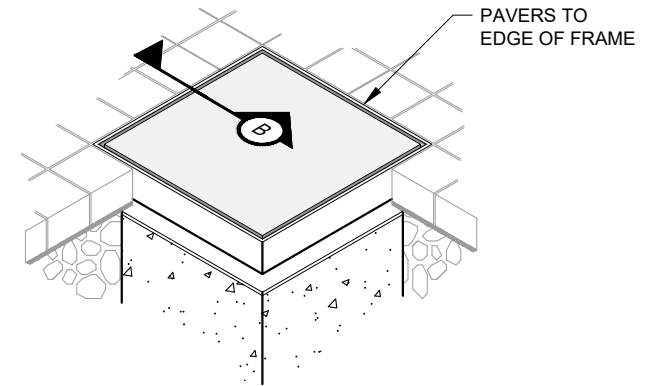

ISOMETRIC - SQUARE FRAME

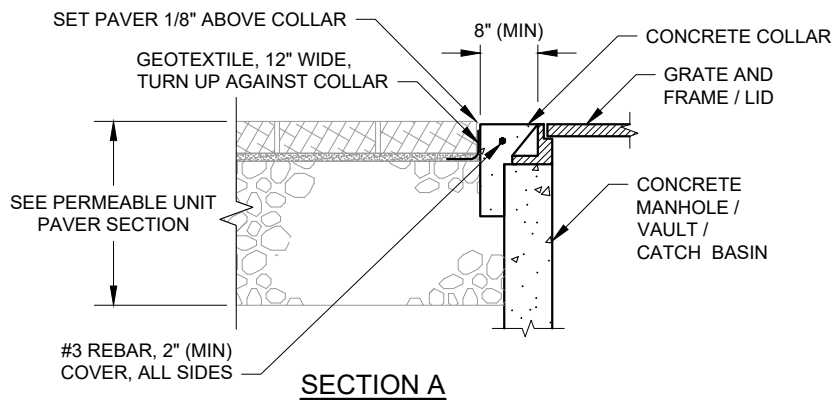

SECTION A

PERMEABLE UNIT PAVER EDGE AT STRUCTURE - VEHICULAR APPLICATIONS

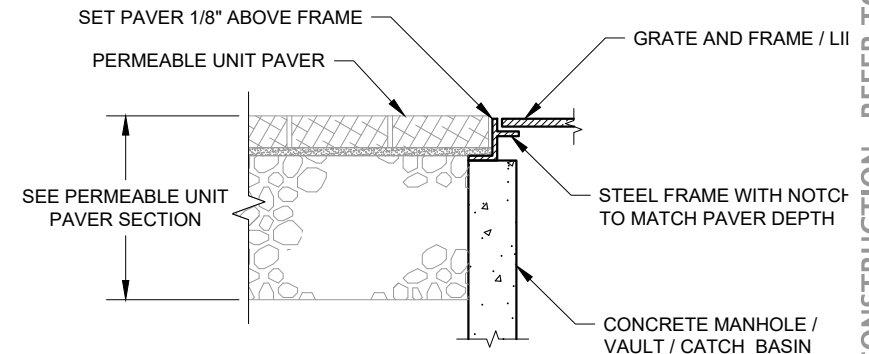

SECTION B

PERMEABLE UNIT PAVER EDGE AT STRUCTURE - PEDESTRIAN APPLICATIONS



CONSTRUCTION NOTES:

- ALL MATERIAL AND WORKMANSHIP FOR EDGE TREATMENTS SHALL CONFORM TO SAN FRANCISCO STANDARD SPECIFICATIONS AND APPLICABLE CODES PER SAN FRANCISCO DBI AND PUBLIC WORKS.

EDGE TREATMENTS						SUBSURFACE CHECK DAMS		SUBSURFACE OUTLETS			
NOTES	KEY MAP	APPLICATIONS				NOTES	COMPONENTS	NOTES	COMPONENTS		
PC 1.1	PC 1.2	PC 1.3	PC 1.4	PC 1.5	PC 1.6	PC 2.1	PC 2.2	PC 3.1	PC 3.2	PC 3.3	PC 3.4



**GREEN INFRASTRUCTURE
TYPICAL DETAILS**
SAN FRANCISCO PUBLIC UTILITIES COMMISSION

DATE	JANUARY 2023
VERSION	3.0
REVISED	

PAVEMENT COMPONENTS
EDGE TREATMENTS
PAVER AT STRUCTURES

DWG NO.
PC 1.6

NOT FOR CONSTRUCTION - REFER TO USER GUIDE

PURPOSE:

PERMEABLE PAVEMENT FACILITIES MUST BE DESIGNED TO PROVIDE SUBSURFACE STORAGE OF STORMWATER TO ALLOW TIME FOR THE WATER TO INFILTRATE INTO THE UNDERLYING SOIL. SLOPED FACILITIES ON POOR SOILS HAVE AN INCREASED POTENTIAL FOR LATERAL FLOWS THROUGH THE STORAGE RESERVOIR COURSE ALONG THE TOP OF THE RELATIVELY IMPERMEABLE SUBGRADE SOIL. THIS REDUCES THE STORAGE AND INFILTRATION CAPACITY OF THE PAVEMENT SYSTEM. SUBSURFACE DETENTION STRUCTURES, OR CHECK DAMS, CAN BE INCORPORATED INTO THE SUBGRADE AND ALIGNED PERPENDICULAR TO THE LONGITUDINAL SUBGRADE SLOPE TO CREATE PONDING IN THE AGGREGATE STORAGE RESERVOIR COURSE TO DETAIN SUBSURFACE FLOW, INCREASE INFILTRATION, AND REDUCE STRUCTURAL PROBLEMS ASSOCIATED WITH SUBGRADE EROSION ON SLOPES.

DESIGNER NOTES & GUIDELINES:

1. THE DESIGNER MUST ADAPT SECTION DRAWINGS TO ADDRESS SITE-SPECIFIC CONDITIONS.
2. WHILE THE DESIGNER MUST DETERMINE IF CHECK DAMS ARE NECESSARY BASED ON SITE-SPECIFIC CONDITIONS, SOME GENERAL GUIDELINES ARE PROVIDED BELOW:

SUBGRADE SOILS	SUBGRADE SLOPE	RUNON FROM OTHER AREAS	CHECK DAM REQUIRED
TYPE A/B	ANY	ALLOWED	NO
TYPE C/D	≤ 2%	NOT ALLOWED	NO
	≤ 2%	ALLOWED	NO*
	> 2%	ALLOWED	YES

* RECOMMENDED FOR SUBSURFACE FLOW PATHS OVER 50 FEET

3. THE DESIGNER MUST ESTABLISH THE HEIGHT AND SPACING OF THE CHECK DAMS BASED ON THE SUBGRADE SLOPE AND THE STORAGE DEPTH REQUIRED TO MEET PROJECT HYDROLOGIC PERFORMANCE GOALS. THE AVERAGE DEPTH OF SUBSURFACE STORAGE ACROSS THE FACILITY AREA MUST MEET THE REQUIRED STORAGE DEPTH. REFER TO CHECK DAM SPACING GUIDANCE ON THIS DRAWING FOR CHECK DAM SPACING CALCULATIONS.
4. MAXIMUM CHECK DAM HEIGHT IS GOVERNED BY 48 HOUR DRAWDOWN REQUIREMENT AND NATIVE SOIL INFILTRATION RATE. SEE **PP 1.1** FOR ADDITIONAL GUIDANCE.
5. THE AREA OF SUBBASE COVERED BY IMPERMEABLE CHECK DAM MATERIAL SHOULD BE EXCLUDED FROM HYDROLOGIC PERFORMANCE CALCULATIONS WHEN THE AREA IS SIGNIFICANT (GREATER THAN 10 PERCENT) RELATIVE TO THE PAVEMENT AREA.
6. THE DESIGNER MUST ENSURE THAT THE RESERVOIR COURSE DEPTH IS SUFFICIENT TO ACCOMMODATE THE HEIGHT OF THE CHECK DAMS WITH THE REQUIRED MINIMUM CLEARANCE.
7. CONVEYANCE CALCULATIONS ARE REQUIRED TO EVALUATE THE NEED FOR SUBSURFACE OUTLETS (E.G., PERFORATED OVERFLOW PIPES SET AT THE DESIGN SUBSURFACE PONDING DEPTH) AND DOWNSLOPE OVERFLOW SYSTEM. REFER TO **PC 3.1**.
8. LOCATE CHECK DAMS TO MINIMIZE IMPACT TO UTILITY ACCESS.
9. LOCATE PERVIOUS CONCRETE CONTROL JOINTS AT CHECK DAM LOCATIONS WHEN CHECK DAM EXTENDS INTO THE STRUCTURAL PAVEMENT SECTION.

DESIGNER CHECKLIST (MUST SPECIFY, AS APPLICABLE):

- CHECK DAM TYPE AND MATERIAL
- CHECK DAM ELEVATION, HEIGHT, AND WIDTH
- CHECK DAM SPACING
- CHECK DAM CLEARANCE (MEASURED FROM BOTTOM OF WEARING COURSE)

CHECK DAM SPACING GUIDANCE:

TYPICAL MAXIMUM SPACING, $L_{SPACING, MAX}$ (FEET) :

$$L_{SPACING, MAX} = D_{DOWNSLOPE} \div S_{SUBSURFACE}$$

$D_{DOWNSLOPE}$ = DOWNSLOPE STORAGE DEPTH (I.E. CHECK DAM HEIGHT) (FEET)

$S_{SUBSURFACE}$ = SUBSURFACE SLOPE (FT/FT)

SPACING, $L_{SPACING}$ (WHEN $L_{SPACING} \leq L_{SPACING, MAX}$) :

$$L_{SPACING} = \frac{2 (D_{AVERAGE} - D_{DOWNSLOPE})}{S_{SUBSURFACE}}$$

$D_{AVERAGE}$ = AVERAGE STORAGE DEPTH (FEET)

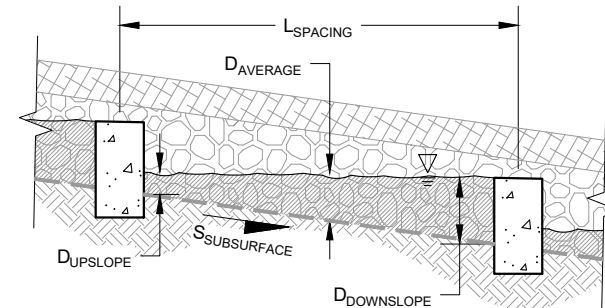

EDGE TREATMENTS						SUBSURFACE CHECK DAMS		SUBSURFACE OUTLETS			
NOTES	KEY MAP	APPLICATIONS				NOTES	COMPONENTS	NOTES	COMPONENTS		
PC 1.1	PC 1.2	PC 1.3	PC 1.4	PC 1.5	PC 1.6	PC 2.1	PC 2.2	PC 3.1	PC 3.2	PC 3.3	PC 3.4



**GREEN INFRASTRUCTURE
TYPICAL DETAILS**
SAN FRANCISCO PUBLIC UTILITIES COMMISSION

DATE
JANUARY 2023
VERSION
3.0
REVISED

**PAVEMENT COMPONENTS
SUBSURFACE CHECK DAMS
DESIGNER NOTES**

DWG NO.
**PC
2.1**

NOT FOR CONSTRUCTION - REFER TO USER GUIDE

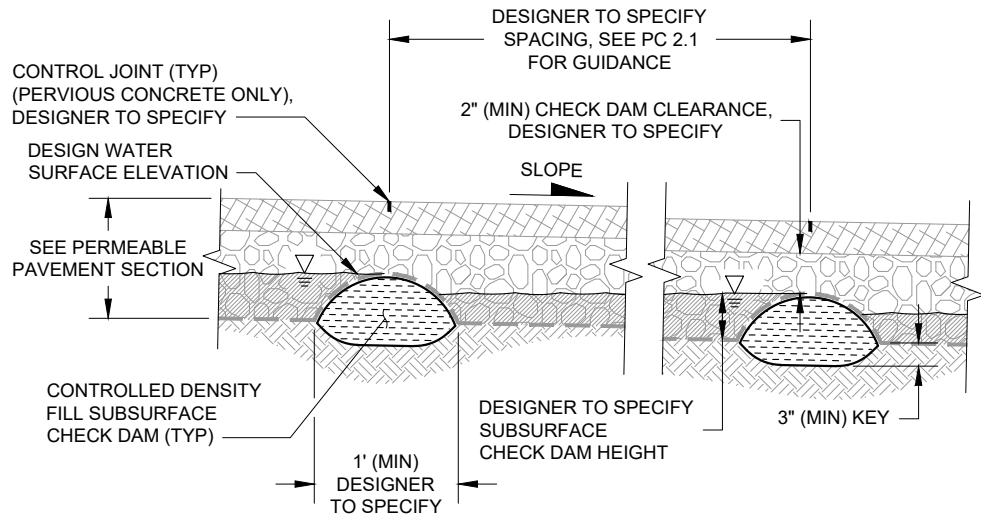

CONTROLLED DENSITY FILL SUBSURFACE CHECK DAM

1

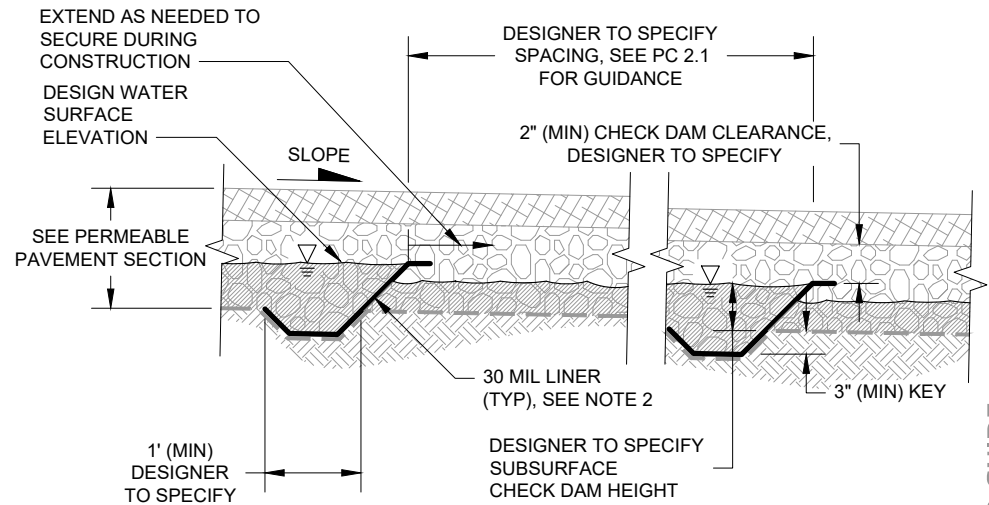

IMPERMEABLE LINER SUBSURFACE CHECK DAM

2

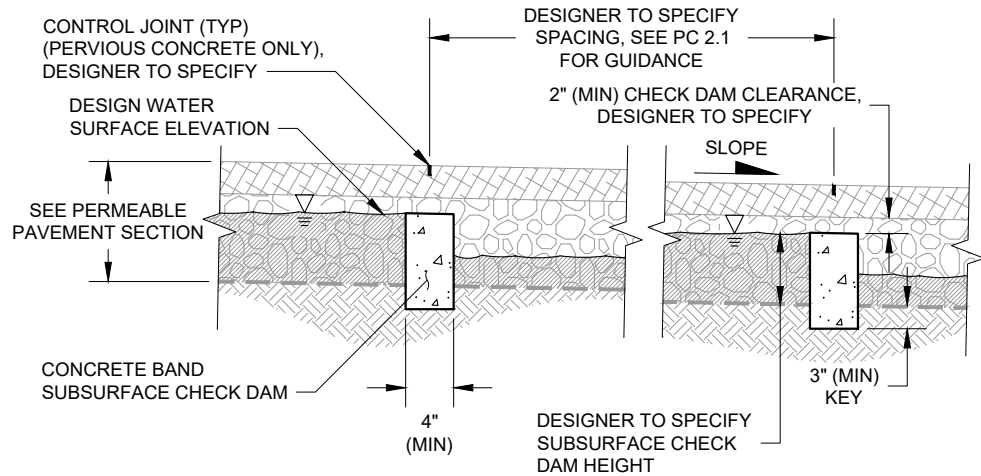

CONCRETE BAND SUBSURFACE CHECK DAM

3

CONSTRUCTION NOTES:

- ALL MATERIAL AND WORKMANSHIP FOR CHECK DAMS SHALL CONFORM TO SAN FRANCISCO STANDARD SPECIFICATIONS AND APPLICABLE CODES PER SAN FRANCISCO DBI AND PUBLIC WORKS.
- LINER SHALL BE HDPE CONFORMING TO GEOSYNTHETIC RESEARCH INSTITUTE (GRI) GM13 OR LLDPE CONFORMING TO GRI GM 17.

EDGE TREATMENTS						SUBSURFACE CHECK DAMS		SUBSURFACE OUTLETS				
NOTES	KEY MAP		APPLICATIONS				NOTES	COMPONENTS	NOTES	COMPONENTS		
PC	PC		PC	PC	PC	PC	PC	PC	PC	PC	PC	PC
1.1	1.2		1.3	1.4	1.5	1.6	2.1	2.2	3.1	3.2	3.3	3.4



**GREEN INFRASTRUCTURE
TYPICAL DETAILS**
SAN FRANCISCO PUBLIC UTILITIES COMMISSION

DATE
JANUARY 2023
VERSION
3.0
REVISED

**PAVEMENT COMPONENTS
SUBSURFACE CHECK DAMS**

DWG NO.
**PC
2.2**

NOT FOR CONSTRUCTION - REFER TO USER GUIDE

PURPOSE:

PERMEABLE PAVEMENT SUBSURFACE OVERFLOWS AND/OR UNDERDRAINS ARE DESIGNED TO CONVEY EXCESS FLOW TO AN APPROVED DISCHARGE POINT. FOR **SUBSURFACE OVERFLOW** CONFIGURATIONS, THE OVERFLOW RISER ELEVATION IS SET AT THE MAXIMUM DESIGN PONDING DEPTH IN THE PAVEMENT BASE. FOR **SUBSURFACE UNDERDRAIN** CONFIGURATIONS, THE CHECK DAM IS SET AT THE MAXIMUM DESIGN PONDING DEPTH IN THE PAVEMENT BASE, AND THE UNDERDRAIN IS LOCATED IN AN UNDERDRAIN TRENCH. WATER BELOW THE OVERFLOW RISER OR CHECK DAM ELEVATION IS TEMPORARILY STORED AND INFILTRATED INTO THE UNDERLYING SUBGRADE. UNDERDRAINS ARE ONLY RECOMMENDED WHEN AN AVAILABLE DAYLIGHT CONDITION EXISTS.

DESIGNER NOTES & GUIDELINES:

- DESIGNERS MUST ADAPT DRAWINGS TO ADDRESS SITE-SPECIFIC CONDITIONS.
- OVERFLOW / UNDERDRAIN PIPES MUST BE LOCATED AT AN ELEVATION HIGHER THAN THE SEWER HYDRAULIC GRADE LINE TO PREVENT BACK FLOW INTO THE PAVEMENT SECTION.
- OVERFLOW IS TYPICALLY PROVIDED BY A SUBSURFACE SLOTTED OVERFLOW PIPE(S) WITH DOWNSTREAM OUTLET CONTROL OR UPSTREAM CHECK DAMS SET AT THE DESIGN PONDING ELEVATION.
- EMERGENCY OVERFLOW FOR LARGE STORM EVENTS CAN BE PROVIDED BY SURFACE SHEET FLOW UPON INUNDATION OF THE PAVEMENT SECTION (REQUIRES SURFACE CONVEYANCE SYSTEM OR OTHER RUNOFF COLLECTION METHOD).
- THE DESIGNER MUST CONSIDER THE FLOW PATH OF WATER WHEN THE PERMEABLE PAVEMENT SECTION IS FULLY SATURATED TO THE MAXIMUM DESIGN DEPTH TO CONFIRM THERE ARE NO UNANTICIPATED DISCHARGE LOCATIONS (E.G., INTERSECTING UTILITY TRENCHES) AND TO ENSURE THE DESIGN PROVIDES EMERGENCY OVERFLOW CONVEYANCE TO AN APPROVED DISCHARGE POINT.
- CONVEYANCE CALCULATIONS ARE REQUIRED TO DESIGN THE OVERFLOW / UNDERDRAIN PIPE DIAMETER AND PIPE SPACING TO SATISFY SFPW HYDRAULIC REQUIREMENTS.
- IF SITE CONSTRAINTS NECESSITATE USE OF OVERFLOW PIPE IN AN AREA SUBJECT TO VEHICULAR TRAFFIC OR OTHER LOADING, APPROPRIATE COVER DEPTH AND PIPE MATERIAL MUST BE DESIGNED.
- WEARING COURSE MAY BE USED TO FULFILL MINIMUM COVER REQUIREMENTS PROVIDED WEARING COURSE IS RIGID PAVEMENT.
- OPTIONAL OBSERVATION PORTS CAN BE USED TO DETERMINE WHETHER AN OVERFLOW / UNDERDRAIN IS DEWATERING PROPERLY. REFER TO **GC 3.1- GC 3.3**.
- OVERFLOW / UNDERDRAIN PIPES MUST BE EQUIPPED WITH CLEANOUTS. REFER TO **GC 5.2**.
- INSTALL OVERFLOW PIPES AT DOWNGRADE END OF PAVEMENT. OVERFLOWS NOT REQUIRED AT EACH CHECK DAM LOCATIONS.
- PIPE MATERIAL SHALL BE DESIGNED PER SAN FRANCISCO ENVIRONMENTAL CODE (CHAPTER 5, SECTION 509 AND CHAPTER 7, SECTION 706).
- AN OUTLET ORIFICE CONTROL DEVICE MAY BE INSTALLED TO FURTHER DETAIN OUTFLOW AND MAXIMIZE INFILTRATION. ENGINEER SHALL DESIGN, DETAIL, SPECIFY, AND CONDUCT SUPPLEMENTAL PERFORMANCE CALCULATIONS AS NEEDED.

DESIGNER CHECKLIST (MUST SPECIFY, AS APPLICABLE):

- OVERFLOW / UNDERDRAIN PIPE MATERIAL, DIAMETER, AND COVER DEPTH
- OVERFLOW / UNDERDRAIN PIPE INVERT ELEVATION AND SLOPE
- OVERFLOW / UNDERDRAIN PIPE ALIGNMENT AND DISCHARGE LOCATION

NOT FOR CONSTRUCTION - REFER TO USER GUIDE

EDGE TREATMENTS						SUBSURFACE CHECK DAMS		SUBSURFACE OUTLETS			
NOTES	KEY MAP	APPLICATIONS				NOTES	COMPONENTS	NOTES	COMPONENTS		
PC	PC	PC	PC	PC	PC	PC	PC	PC	PC	PC	PC
1.1	1.2	1.3	1.4	1.5	1.6	2.1	2.2	3.1	3.2	3.3	3.4



**GREEN INFRASTRUCTURE
TYPICAL DETAILS**
SAN FRANCISCO PUBLIC UTILITIES COMMISSION

DATE	JANUARY 2023
VERSION	3.0
REVISED	

**PAVEMENT COMPONENTS
SUBSURFACE OVERFLOWS
DESIGNER NOTES**

DWG. NO.	PC 3.1
----------	------------------

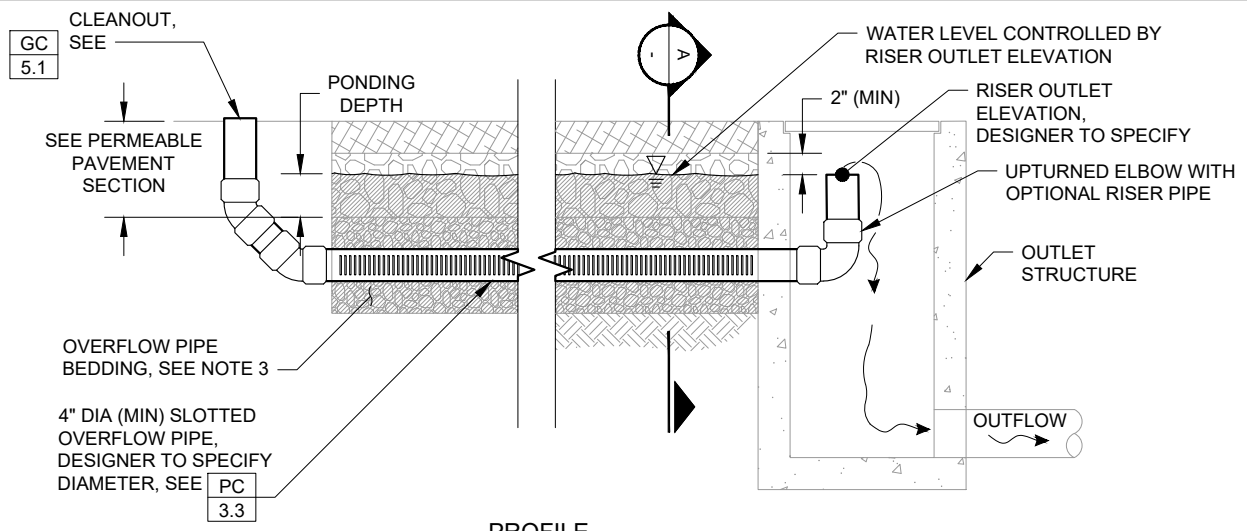

PROFILE
OVERFLOW CONTROL STRUCTURE WITH RISER 1

- CONSTRUCTION NOTES:**
1. ALL MATERIAL AND WORKMANSHIP FOR OVERFLOW STRUCTURES SHALL CONFORM TO SAN FRANCISCO STANDARD SPECIFICATIONS AND APPLICABLE CODES PER SAN FRANCISCO DBI AND PUBLIC WORKS.
 2. LOCATE OVERFLOW PIPE BELOW STRUCTURAL PAVEMENT BASE DEPTH.
 3. OVERFLOW PIPE BEDDING SHALL BE ASTM NO. 57 CONFORMING TO THE REQUIREMENTS OF GRAVEL BASE MATERIAL FOR PAVEMENTS, UNLESS OTHERWISE SPECIFIED.

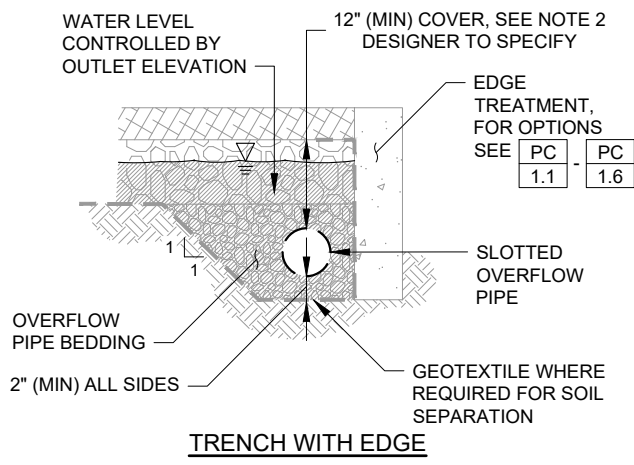

TRENCH WITH EDGE

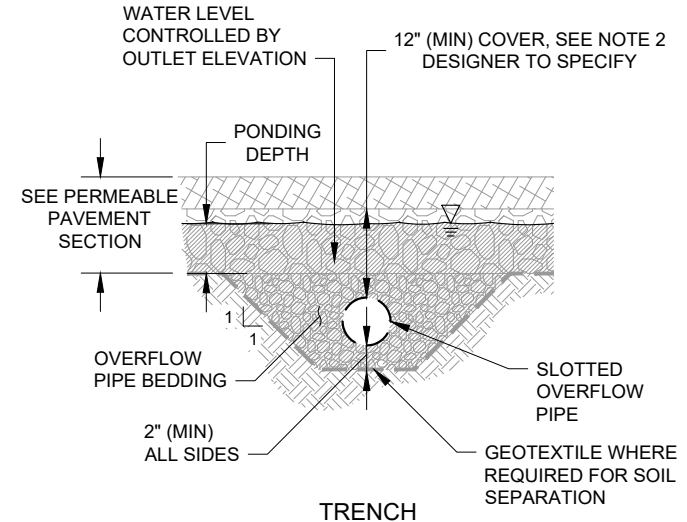

TRENCH

OVERFLOW PIPE TRENCH SECTION A

EDGE TREATMENTS						SUBSURFACE CHECK DAMS		SUBSURFACE OUTLETS			
NOTES	KEY MAP	APPLICATIONS				NOTES	COMPONENTS	NOTES	COMPONENTS		
PC 1.1	PC 1.2	PC 1.3	PC 1.4	PC 1.5	PC 1.6	PC 2.1	PC 2.2	PC 3.1	PC 3.2	PC 3.3	PC 3.4



**GREEN INFRASTRUCTURE
TYPICAL DETAILS**

SAN FRANCISCO PUBLIC UTILITIES COMMISSION

DATE	JANUARY 2023
VERSION	3.0
REVISED	

**PAVEMENT COMPONENTS
SUBSURFACE OVERFLOW**

DWG NO.
**PC
3.2**

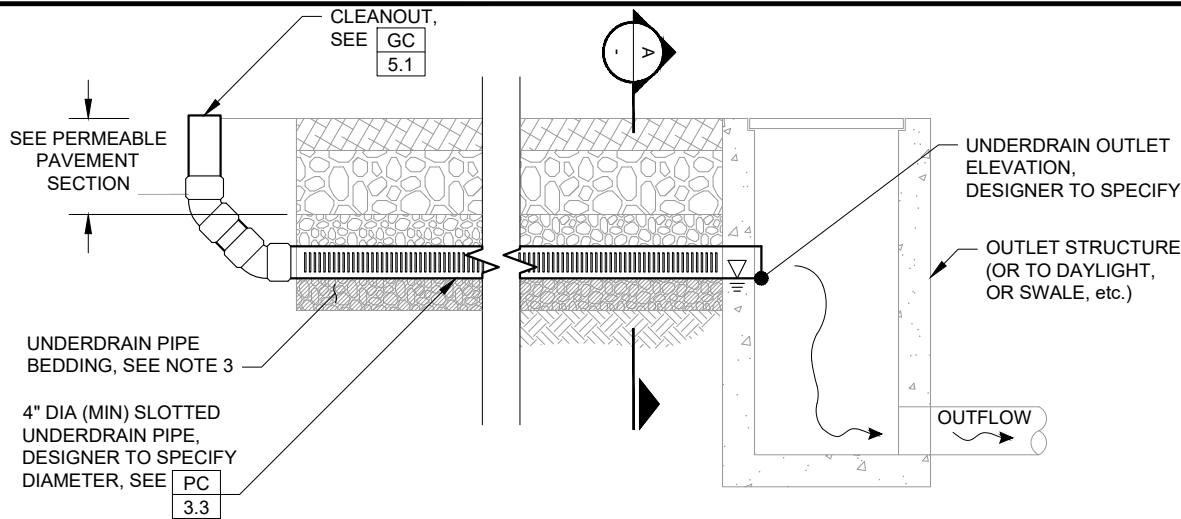

PROFILE

UNDERDRAIN TO DAYLIGHT ①

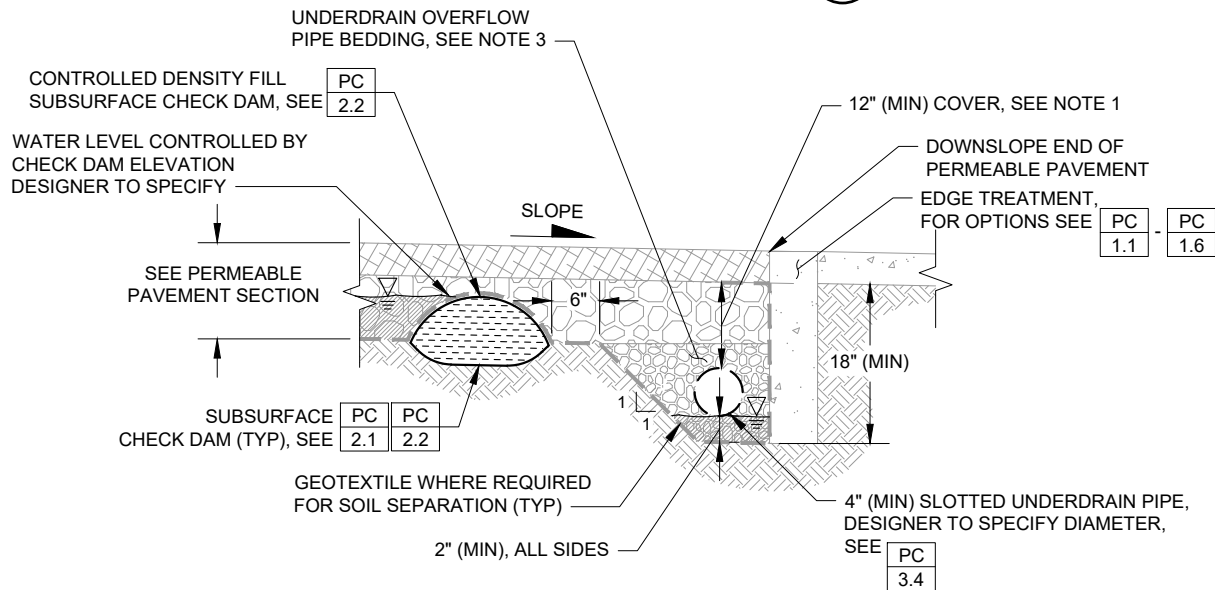

CHECK DAM-CONTROLLED WITH UNDERDRAIN A

CONSTRUCTION NOTES:

1. ALL MATERIAL AND WORKMANSHIP FOR OVERFLOW STRUCTURES SHALL CONFORM TO SAN FRANCISCO STANDARD SPECIFICATIONS AND APPLICABLE CODES PER SAN FRANCISCO DBI AND PUBLIC WORKS.
2. LOCATE UNDERDRAIN PIPE BELOW STRUCTURAL PAVEMENT BASE DEPTH.
3. UNDERDRAIN PIPE BEDDING SHALL BE ASTM NO. 57 CONFORMING TO THE REQUIREMENTS OF GRAVEL BASE MATERIAL FOR PAVEMENTS, UNLESS OTHERWISE SPECIFIED.

EDGE TREATMENTS						SUBSURFACE CHECK DAMS		SUBSURFACE OUTLETS			
NOTES	KEY MAP	APPLICATIONS				NOTES	COMPONENTS	NOTES	COMPONENTS		
PC 1.1	PC 1.2	PC 1.3	PC 1.4	PC 1.5	PC 1.6	PC 2.1	PC 2.2	PC 3.1	PC 3.2	PC 3.3	PC 3.4



**GREEN INFRASTRUCTURE
TYPICAL DETAILS**
SAN FRANCISCO PUBLIC UTILITIES COMMISSION

DATE
JANUARY 2023
VERSION
3.0
REVISED

**PAVEMENT COMPONENTS
SUBSURFACE UNDERDRAIN**

DWG NO.
**PC
3.3**

NOT FOR CONSTRUCTION - REFER TO USER GUIDE

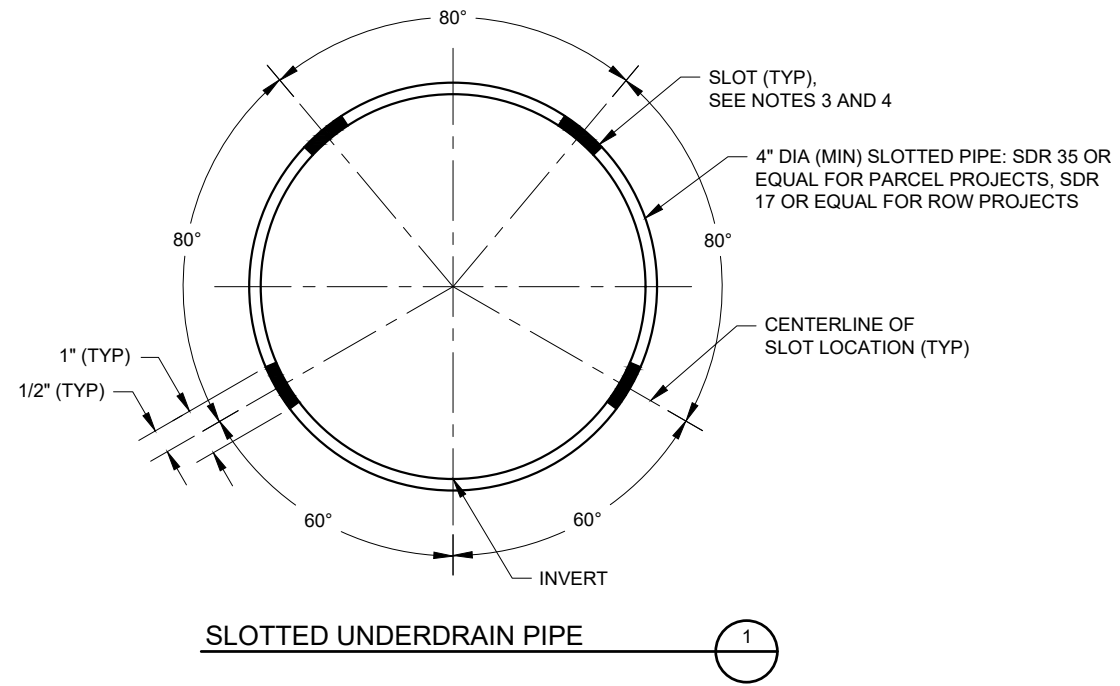

SLOTTED UNDERDRAIN PIPE (1)

CONSTRUCTION NOTES:

1. SINGLE WALL AND DUAL WALL CORRUGATED PIPE (AASHTO M252 AND M294 TYPES C, S, AND D) ARE NOT ALLOWED.
2. PVC PIPE IS NOT ALLOWED FOR CITY PROJECTS AND CITY-ACCEPTED ASSETS (REFER TO SF ENVIRONMENT CODE CHAPTER 5 SECTION 509 FOR ACCEPTABLE MATERIALS).
3. ALL PERFORATIONS SHALL BE SLOTTED TYPE, MEASURING 0.064 INCH WIDE (MAX), SPACED AT 0.30 INCH ON CENTER, AND PROVIDING A MINIMUM INLET AREA OF 10.0 SQUARE INCH PER LINEAR FOOT OF PIPE. OTHER SLOT CONFIGURATIONS PROVIDING A MINIMUM INLET AREA OF 10.0 SQUARE INCHES PER LINEAR FOOT OF PIPE MAY BE SUBMITTED FOR APPROVAL BY SFPUC.
4. SLOTS SHALL BE ORIENTED PERPENDICULAR TO LONG AXIS OF PIPE, AND EVENLY SPACED AROUND CIRCUMFERENCE AND LENGTH OF PIPE.
5. SLOTTED UNDERDRAIN, CLEANOUT PIPE, AND FITTINGS SHALL BE OF SAME SIZE AND MATERIAL.
6. ALL MATERIAL AND WORKMANSHIP FOR UNDERDRAINS SHALL CONFORM TO SAN FRANCISCO STANDARD SPECIFICATIONS AND APPLICABLE CODES PER SAN FRANCISCO DBI AND PUBLIC WORKS.
7. SET CROWN OF UNDERDRAIN PIPE AT OR BELOW BOTTOM OF LEVELING COURSE. SEE DESIGNER NOTES FOR ADDITIONAL GUIDANCE ON LOCATING UNDERDRAIN PIPE IN GRAVEL STORAGE.
8. LONGITUDINAL SLOPE OF UNDERDRAIN PIPE SHALL BE 0.5% MINIMUM UNLESS APPROVED BY SFPUC (PARCEL APPLICATIONS ONLY).

EDGE TREATMENTS						SUBSURFACE CHECK DAMS		SUBSURFACE OUTLETS				
NOTES	KEY MAP		APPLICATIONS				NOTES	COMPONENTS	NOTES	COMPONENTS		
PC	PC		PC	PC	PC	PC	PC	PC	PC	PC	PC	PC
1.1	1.2		1.3	1.4	1.5	1.6	2.1	2.2	3.1	3.2	3.3	3.4



**GREEN INFRASTRUCTURE
TYPICAL DETAILS**
SAN FRANCISCO PUBLIC UTILITIES COMMISSION

DATE	JANUARY 2023
VERSION	3.0
REVISED	

**PAVEMENT COMPONENTS
UNDERDRAIN PIPE**

DWG NO.
**PC
3.4**

PURPOSE:

ROADSIDE BIORETENTION PLANTERS IN:

- CSS AREAS: CONTROL PEAK FLOWS AND VOLUMES OF STORMWATER RUNOFF BY PROVIDING SURFACE, SUBSURFACE STORAGE AND INFILTRATION INTO NATIVE SOIL.
- MS4 AREAS: REMOVE POLLUTANTS OF CONCERN AS WATER FILTERS THROUGH BIORETENTION SOIL.

DESIGNER NOTES & GUIDELINES:

1. THE DESIGNER MUST ADAPT PLAN AND SECTION DRAWINGS TO ADDRESS SITE-SPECIFIC CONDITIONS.
2. PLANTER AREA, PONDING DEPTH, BIORETENTION SOIL DEPTH, AND AGGREGATE STORAGE DEPTH MUST BE SIZED TO MEET PROJECT HYDROLOGIC PERFORMANCE GOALS.
3. PONDING AND BIORETENTION SOIL DRAWDOWN TIME (I.E., TIME FOR MAXIMUM SURFACE PONDING TO DRAIN THROUGH THE BIORETENTION SOIL AFTER THE END OF A STORM) RECOMMENDATIONS:
 - 3 - 12 HOUR PONDING AND BIORETENTION SOIL DRAWDOWN (TYPICAL)
 - 24 HOUR MAXIMUM PONDING AND BIORETENTION SOIL DRAWDOWN
4. FACILITY DRAWDOWN TIME (I.E., TIME FOR SURFACE PONDING TO DRAIN THROUGH THE ENTIRE SECTION INCLUDING AGGREGATE STORAGE AFTER THE END OF A STORM) REQUIREMENTS:
 - 48 HOUR MAXIMUM FACILITY DRAWDOWN (I.E. ORIFICE CONTROLLED SYSTEM OR EXTENDED STORAGE DEPTH WITHIN INFILTRATION SYSTEM)
5. AN AGGREGATE COURSE UNDER THE BIORETENTION SOIL IS REQUIRED FOR BIORETENTION IN SEPARATE SEWER SYSTEM AREAS. USE AGGREGATE COURSE WHERE REQUIRED (E.G., WITH UNDERDRAIN, FOR STORAGE, ETC.) FOR FACILITIES IN COMBINED SEWER SYSTEM AREAS.
6. THE PLANTER WALL SLOPE IS TYPICALLY DESIGNED TO MATCH THE LONGITUDINAL SLOPE OF THE ADJACENT ROADWAY/SIDEWALK. CHECK DAMS MAY BE USED FOR HIGHER-SLOPED INSTALLATIONS TO TERRACE FACILITIES TO PROVIDE SUFFICIENT PONDING AND TO MINIMIZE LARGE ELEVATION DROPS FROM ADJACENT SURFACES. DESIGNER MUST SPECIFY CHECK DAM HEIGHT AND SPACING. REFER TO **BC 6.1** AND **BC 6.2** FOR GUIDANCE ON CHECK DAM DESIGN.
7. THE DESIGN SHALL MINIMIZE THE HEIGHT OF EXPOSED PLANTER WALLS BETWEEN THE TOP OF SOIL AND TOP OF CURB WALL AND CONSIDER PEDESTRIAN AND VEHICLE SAFETY, ACCESSIBILITY REQUIREMENTS, AND OVERALL AESTHETICS. DEPENDING ON THE HEIGHT OF THE PROPOSED PLANTER WALL, ADDITIONAL STRUCTURAL CONSIDERATIONS MAY BE REQUIRED TO ADDRESS WALL LOADING. REFER TO **BC 1.1** THROUGH **BC 1.7** FOR GUIDANCE ON EDGE TREATMENTS.
8. WHEN FACILITY CONSTRUCTION IMPACTS EXISTING SIDEWALK, ALL SAW CUTS MUST ADHERE TO SFPUC REQUIREMENTS. SAW CUTS SHOULD BE ALONG SCORE LINES AND ANY DISTURBED SIDEWALK FLAGS SHOULD BE REPLACED IN THEIR ENTIRETY.
9. BIORETENTION PLANTERS LOCATED IN PUBLIC ROW SHOULD BE DESIGNED WITH AN OFFLINE CONFIGURATION (I.E. NO OVERFLOW STRUCTURE TO SD LATERAL; CURB CUTS SERVE AS INLET AND OVERFLOW TO GUTTER FLOW LINE). ONLINE BIORETENTION CONFIGURATION (I.E. OVERFLOW STRUCTURE WITHIN PLANTER TO SD LATERAL) REQUIRES SFPUC APPROVAL. HARD-PIPED DISCHARGE INTO ROW BIORETENTION PLANTERS MAY REQUIRE AN ONLINE CONFIGURATION.
10. FOR APPROVED ONLINE CONFIGURATIONS: OVERFLOW STRUCTURE (MATERIAL AND WORKMANSHIP) SHALL CONFORM TO APPLICABLE CODES AND REQUIREMENTS. SIZE AND MODEL OF ATRIUM GRATE AT OVERFLOW TO BE DETERMINED BY ENGINEER TO ENSURE CONVEYANCE OF PEAK FLOW.
11. PLANTER VEGETATION MUST BE SPECIFIED BY DESIGN PROFESSIONAL PER SFPUC VEGETATION PALLETTE.
12. THE DESIGNER MUST EVALUATE UTILITY SURVEYS FOR POTENTIAL UTILITY CROSSINGS OR CONFLICTS. REFER TO **GC 2.1 - GC 2.12** FOR UTILITY CROSSING DETAILS AND **GC 3.1 - GC 3.4** FOR UTILITY CROSSING CONFLICT DETAILS.
13. MINIMUM UTILITY SETBACKS AND PROTECTION MEASURES MUST CONFORM TO CURRENT SFPUC ASSET PROTECTION STANDARDS AND OTHER UTILITY PROVIDER REQUIREMENTS.

RELATED COMPONENTS		
EDGE TREATMENTS:	BC 1.1	BC 1.7
INLETS:	BC 2.1	BC 2.4
OUTLETS:	BC 3.1	BC 3.4
AGGREGATE STORAGE:	BC 4.1	
UNDERDRAINS:	BC 5.1	BC 5.2
CHECK DAMS:	BC 6.1	BC 6.2
LINERS:	GC 1.1	GC 1.2
UTILITY CROSSINGS:	GC 2.1	GC 2.12
UTILITY CONFLICTS:	GC 3.1	GC 3.4
OBSERVATION PORTS:	GC 4.1	GC 4.3
CLEANOUTS:	GC 5.1	

RELATED SPECIFICATIONS	CSI NO.
BIORETENTION: - BIORETENTION SOIL MIX - AGGREGATE STORAGE - MULCH - STREAMBED COBBLES	33 47 27

ROADSIDE APPLICATIONS												PARCEL APPLICATIONS						
NOTES		W/PARKING		W/O PARKING		BULBOUT						NOTES		PLAN		SECTIONS		
BP 1.1	BP 1.2	BP 2.1	BP 2.2	BP 3.1	BP 3.2	BP 4.1	BP 4.2	BP 4.3	BP 4.4	BP 4.5	BP 4.6	BP 5.1	BP 5.2	BP 5.3	BP 5.4	BP 5.5	BP 5.6	BP 5.7



**GREEN INFRASTRUCTURE
TYPICAL DETAILS**
SAN FRANCISCO PUBLIC UTILITIES COMMISSION

DATE	JANUARY 2023
VERSION	3.0
REVISED	

**ROADSIDE PLANTER
DESIGNER NOTES (1 OF 2)**

DWG NO.
**BP
1.1**

NOT FOR CONSTRUCTION - REFER TO USER GUIDE

LAYOUT REQUIREMENTS:

1. REFER TO THE SAN FRANCISCO STANDARD ACCESSIBILITY REQUIREMENTS IN THE SAN FRANCISCO PUBLIC WORKS SIDEWALK LANDSCAPING REFERENCE DRAWINGS AND SPECIFICATIONS FOR COURTESY STRIP, THROUGHWAY, PARKING SPACE AND ACCESSIBLE PATH REQUIREMENTS.
2. LOCATE CURB CUTS AND GUTTER MODIFICATIONS TO AVOID CONFLICTS WITH ACCESSIBILITY REQUIREMENTS (E.G., OVERFLOWS SHALL DISCHARGE TO CB OR INLET PRIOR TO CROSSING A CURB RAMP OR CROSSWALK).
3. REFER TO **SHEET GEN 0.2** AND APPENDIX C OF THE STORMWATER MANAGEMENT REQUIREMENTS FOR MORE DETAILED INFORMATION ON SITING AND DESIGN REQUIREMENTS FOR INFILTRATION-BASED BMPS.

DESIGNER CHECKLIST (MUST SPECIFY, AS APPLICABLE):

- PLANTER WIDTH AND LENGTH
- DEPTH OF PONDING
- DEPTH OF FREEBOARD
- DEPTH OF BIORETENTION SOIL
- DEPTH AND TYPE OF AGGREGATE STORAGE, IF ANY
- PLANTER SURFACE ELEVATION (TOP OF BIORETENTION SOIL) AT UPSLOPE AND DOWNSLOPE ENDS OF FACILITY (I.E., PROVIDE SPOTS AND/OR CONTOURS AS NEEDED).
- DEFINED SURVEY POINTS AT EVERY PLANTER WALL CORNER AND POINT OF TANGENCY
- HORIZONTAL CONTROL: DIMENSIONS AND DISTANCE TO EVERY INLET, OUTLET, CHECK DAM, SIDEWALK NOTCH, ETC.
- VERTICAL CONTROL: ELEVATIONS OF EVERY INLET, OUTLET, STRUCTURE RIM AND INVERT, CHECK DAM, PLANTER WALL CORNER, AND SIDEWALK NOTCH
- TYPE AND DESIGN OF PLANTER COMPONENTS (E.G., EDGE TREATMENTS, INLETS/GUTTER MODIFICATIONS, UTILITY CROSSINGS, LINER, AND PLANTING DETAILS)

NOT FOR CONSTRUCTION - REFER TO USER GUIDE

ROADSIDE APPLICATIONS												PARCEL APPLICATIONS						
NOTES		W/PARKING		W/O PARKING		BULBOUT						NOTES		PLAN		SECTIONS		
BP 1.1	BP 1.2	BP 2.1	BP 2.2	BP 3.1	BP 3.2	BP 4.1	BP 4.2	BP 4.3	BP 4.4	BP 4.5	BP 4.6	BP 5.1	BP 5.2	BP 5.3	BP 5.4	BP 5.5	BP 5.6	BP 5.7



**GREEN INFRASTRUCTURE
TYPICAL DETAILS**
SAN FRANCISCO PUBLIC UTILITIES COMMISSION

DATE	JANUARY 2023
VERSION	3.0
REVISED	

**ROADSIDE PLANTER
DESIGNER NOTES (2 OF 2)**

DWG NO.
**BP
1.2**

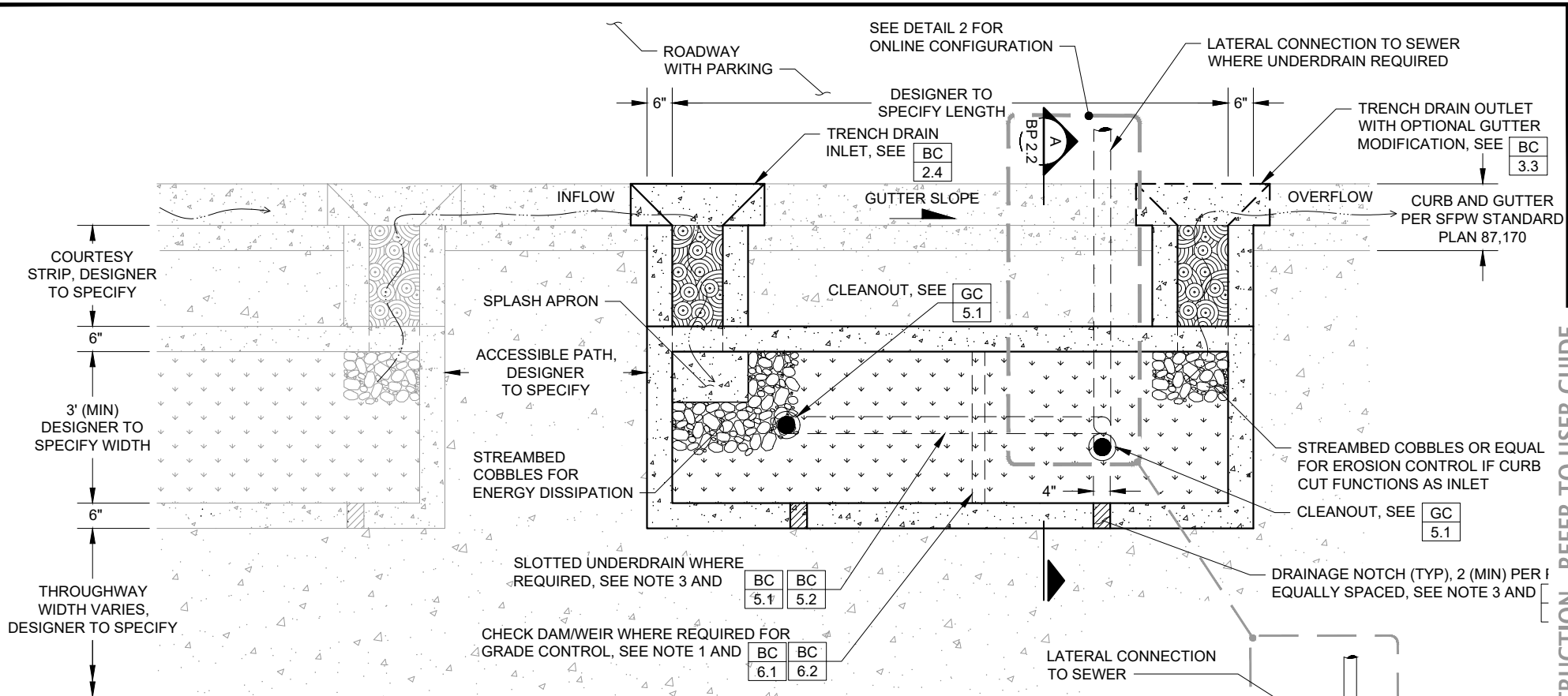

PLAN - OFFLINE CONFIGURATION 1

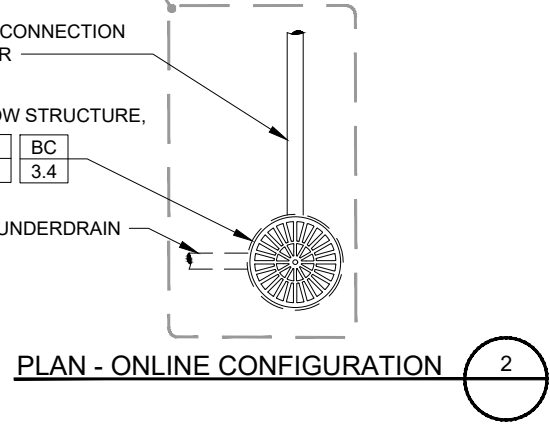

CONSTRUCTION NOTES:

1. CHECK DAMS/WEIRS SHALL BE SPACED TO PROVIDE PONDING PER SITE SPECIFIC DESIGN.
2. LAY OUT DRAINAGE NOTCHES TO PREVENT PONDING BEHIND PLANTER WALL WITH 5' MAXIMUM SPACING BETWEEN NOTCHES.
3. PROVIDE ONE CLEANOUT PER PLANTER (MIN) FOR FACILITIES WITH UNDERDRAINS.
4. MINIMUM UTILITY SETBACKS AND PROTECTION MEASURES MUST CONFORM TO CURRENT SFPUC ASSET PROTECTION STANDARDS. COORDINATE WITH ENGINEER IN THE EVENT OF UTILITY CROSSING AND UTILITY CONFLICTS.
5. PUBLIC ROW/SFPUC ASSETS: SHALL BE OFFLINE CONFIGURATION, SEE BP 1.1.
6. PRIVATE PARCEL: OFFLINE OR ONLINE CONFIGURATION ALLOWED.

ROADSIDE APPLICATIONS												PARCEL APPLICATIONS						
NOTES		W/PARKING		W/O PARKING		BULBOUT						NOTES		PLAN		SECTIONS		
BP 1.1	BP 1.2	BP 2.1	BP 2.2	BP 3.1	BP 3.2	BP 4.1	BP 4.2	BP 4.3	BP 4.4	BP 4.5	BP 4.6	BP 5.1	BP 5.2	BP 5.3	BP 5.4	BP 5.5	BP 5.6	BP 5.7



**GREEN INFRASTRUCTURE
TYPICAL DETAILS**
SAN FRANCISCO PUBLIC UTILITIES COMMISSION

DATE	JANUARY 2023
VERSION	3.0
REVISED	

**BIORETENTION PLANTER
ROADSIDE PLANTER WITH PARKING
PLAN**

DWG NO.
**BP
2.1**

NOT FOR CONSTRUCTION - REFER TO USER GUIDE

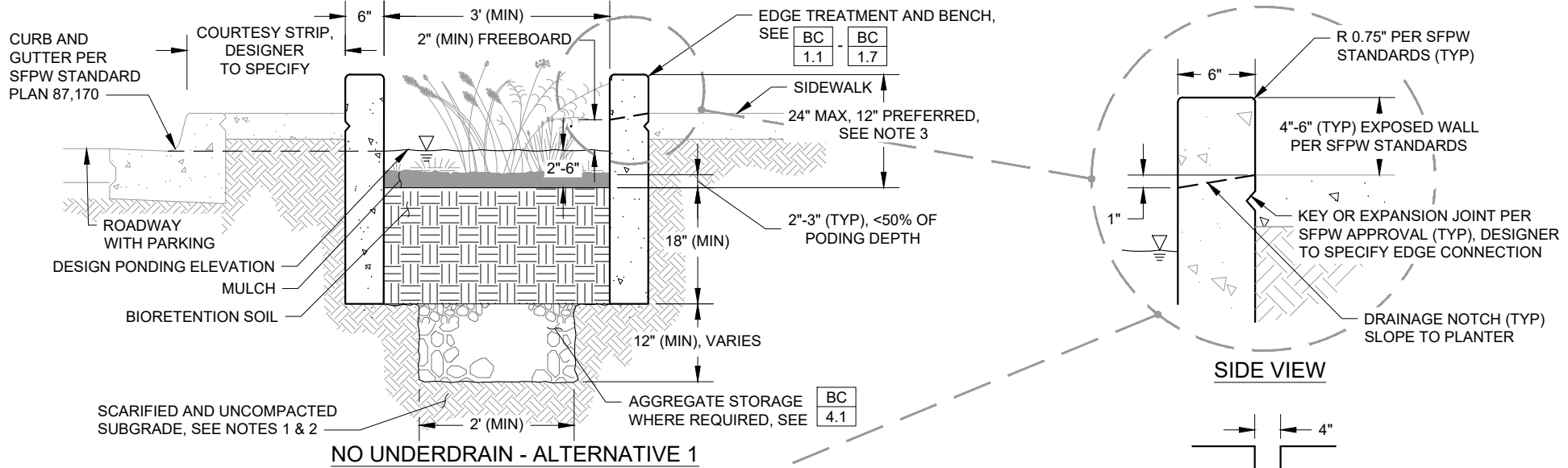

NO UNDERDRAIN - ALTERNATIVE 1

TYPICAL DRAINAGE NOTCH DETAIL

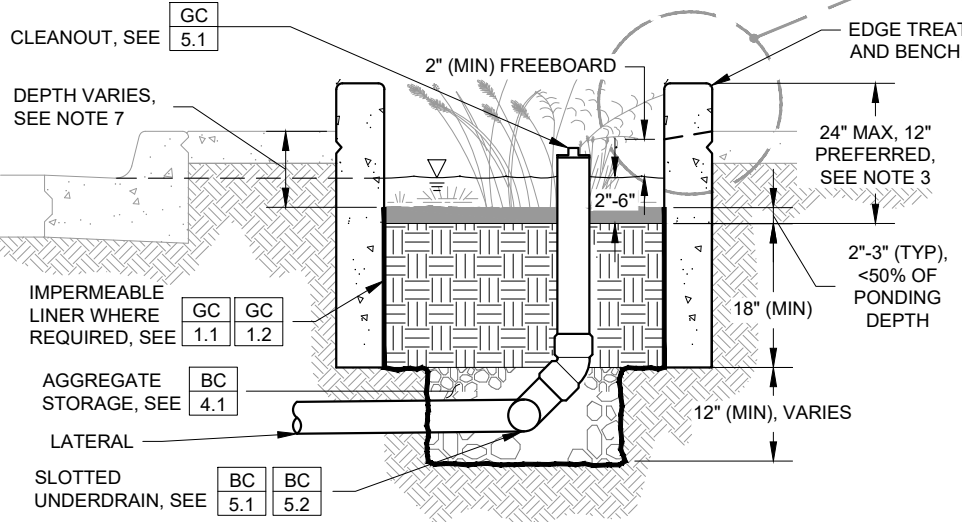

OFFLINE CONFIGURATION WITH UNDERDRAIN - ALTERNATIVE 2

CONSTRUCTION NOTES:

1. AVOID COMPACTION OF EXISTING SUBGRADE BELOW PLANTER DURING CONSTRUCTION.
2. SCARIFY SUBGRADE TO A DEPTH OF 3 INCHES (MIN) IMMEDIATELY PRIOR TO PLACEMENT OF AGGREGATE STORAGE AND BIORETENTION SOIL MATERIAL.
3. MAXIMUM DROP FROM TOP OF CURB/WALL TO TOP OF BIORETENTION SOIL SHALL INCLUDE CONSIDERATIONS FOR BIORETENTION SOIL SETTLEMENT. 30" DROP REQUIRES GUARD RAIL.
4. SLOPE TOP OF PLANTER WALL TO MATCH LONGITUDINAL SLOPE OF ADJACENT SURFACE.
5. SEE **BC 3.4** FOR ONLINE CONFIGURATIONS WITH OVERFLOW STRUCTURE.
6. PRIOR TO PLACEMENT OF IMPERMEABLE LINER, THE SUBGRADE SHALL BE PREPARED AND CONTOURED AS NECESSARY TO PROVIDE A SMOOTH SURFACE, VOID OF SHARP ROCK/DEBRIS. NO VOID SPACES SHALL BE PRESENT BETWEEN THE LINER AND THE SUBGRADE. GEOTEXTILE FABRIC MAY BE INSTALLED BETWEEN THE SUBGRADE AND THE LINER TO PROTECT THE LINER FROM SHARP AGGREGATE PRESENT IN THE SUBGRADE. ENGINEER SHALL INSPECT/APPROVE THE PREPARED BASIN SUBGRADE PRIOR TO THE INSTALLATION OF ANY OVERLYING GEOTEXTILE MATERIAL. SEE BIORETENTION SPECIFICATION.
7. MAXIMUM DROP FROM TOP OF WALKING SURFACE TO TOP OF MULCH SHALL INCLUDE CONSIDERATIONS FOR SOIL SETTLEMENT.

BIORETENTION PLANTER WITH PARKING (A)

ROADSIDE APPLICATIONS												PARCEL APPLICATIONS						
NOTES		W/PARKING		W/O PARKING		BULBOUT						NOTES		PLAN		SECTIONS		
BP 1.1	BP 1.2	BP 2.1	BP 2.2	BP 3.1	BP 3.2	BP 4.1	BP 4.2	BP 4.3	BP 4.4	BP 4.5	BP 4.6	BP 5.1	BP 5.2	BP 5.3	BP 5.4	BP 5.5	BP 5.6	BP 5.7



**GREEN INFRASTRUCTURE
TYPICAL DETAILS**
SAN FRANCISCO PUBLIC UTILITIES COMMISSION

DATE	JANUARY 2023
VERSION	3.0
REVISED	

**BIORETENTION PLANTER
ROADSIDE PLANTER WITH PARKING
SECTIONS**

DWG NO.
**BP
2.2**

NOT FOR CONSTRUCTION - REFER TO USER GUIDE

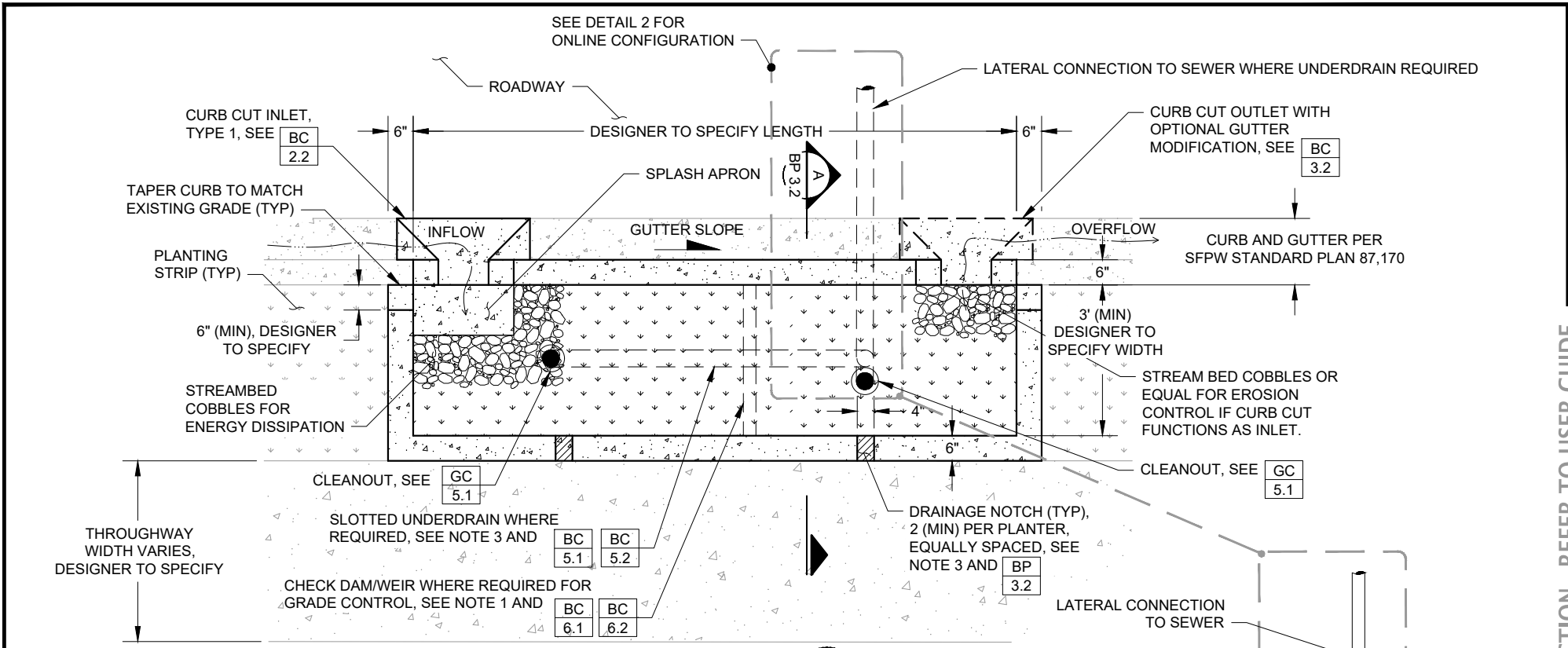

PLAN - OFFLINE CONFIGURATION 1

CONSTRUCTION NOTES:

1. CHECK DAMS SHALL BE SPACED TO PROVIDE PONDING PER SITE SPECIFIC DESIGN.
2. LAY OUT DRAINAGE NOTCHES TO PREVENT PONDING BEHIND PLANTER WALL WITH 5' MAXIMUM SPACING BETWEEN NOTCHES.
3. PROVIDE ONE CLEANOUT PER PLANTER (MIN) FOR FACILITIES WITH UNDERDRAINS.
4. MINIMUM UTILITY SETBACKS AND PROTECTION MEASURES MUST CONFORM TO CURRENT SFPUC ASSET PROTECTION STANDARDS. COORDINATE WITH ENGINEER IN THE EVENT OF UTILITY CROSSING AND UTILITY CONFLICTS.
5. PUBLIC ROW/SFPUC ASSETS: SHALL BE OFFLINE CONFIGURATION, SEE BP 1.1.
6. PRIVATE PARCEL: OFFLINE OR ONLINE CONFIGURATION ALLOWED.
7. PRIOR TO PLACEMENT OF IMPERMEABLE LINER, THE SUBGRADE SHALL BE PREPARED AND CONTOURED AS NECESSARY TO PROVIDE A SMOOTH SURFACE, VOID OF SHARP ROCK/DEBRIS. NO VOID SPACES SHALL BE PRESENT BETWEEN THE LINER AND THE SUBGRADE. GEOTEXTILE FABRIC MAY BE INSTALLED BETWEEN THE SUBGRADE AND THE LINER TO PROTECT THE LINER FROM SHARP AGGREGATE PRESENT IN THE SUBGRADE. ENGINEER SHALL INSPECT/APPROVE THE PREPARED BASIN SUBGRADE PRIOR TO THE INSTALLATION OF ANY OVERLYING GEOTEXTILE MATERIAL. SEE BIORETENTION SPECIFICATION.

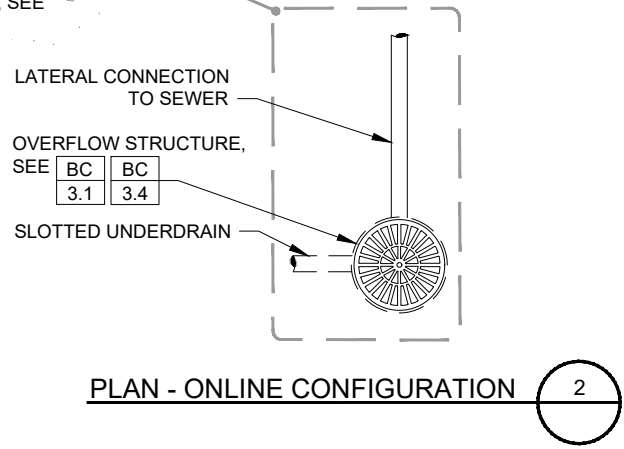

PLAN - ONLINE CONFIGURATION 2

ROADSIDE APPLICATIONS												PARCEL APPLICATIONS						
NOTES		W/PARKING		W/O PARKING		BULBOUT						NOTES		PLAN		SECTIONS		
BP 1.1	BP 1.2	BP 2.1	BP 2.2	BP 3.1	BP 3.2	BP 4.1	BP 4.2	BP 4.3	BP 4.4	BP 4.5	BP 4.6	BP 5.1	BP 5.2	BP 5.3	BP 5.4	BP 5.5	BP 5.6	BP 5.7



**GREEN INFRASTRUCTURE
TYPICAL DETAILS**
SAN FRANCISCO PUBLIC UTILITIES COMMISSION

DATE	JANUARY 2023
VERSION	3.0
REVISED	

**BIORETENTION PLANTER
ROADSIDE PLANTER WITHOUT PARKING
PLAN**

DWG NO.
**BP
3.1**

NOT FOR CONSTRUCTION - REFER TO USER GUIDE

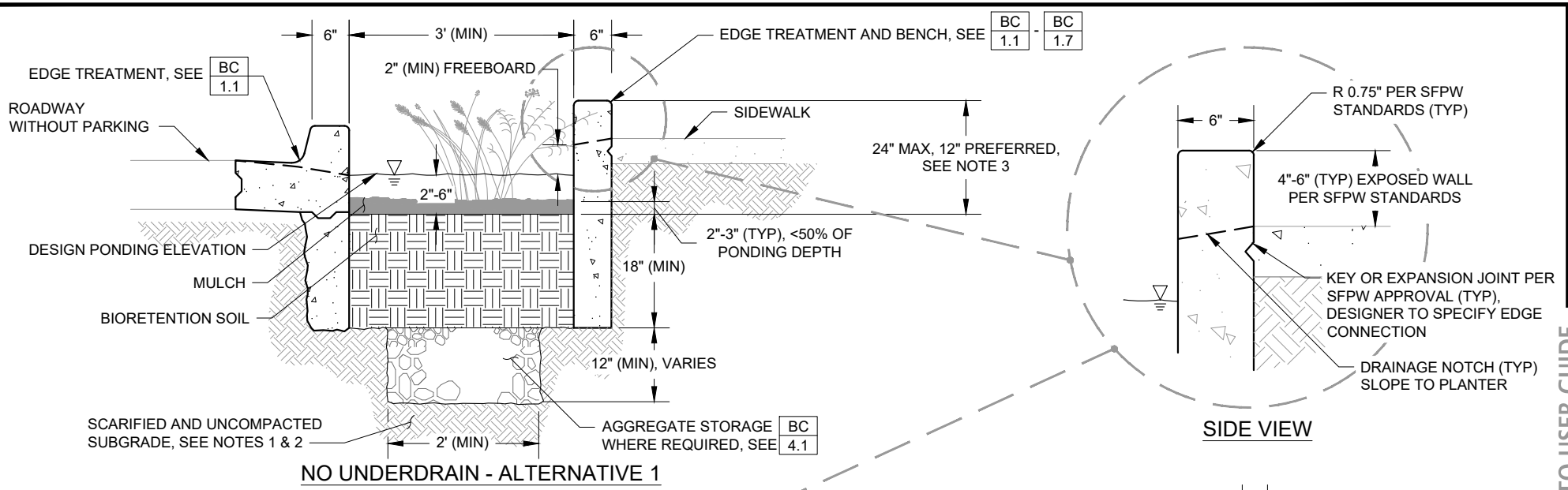

NO UNDERDRAIN - ALTERNATIVE 1

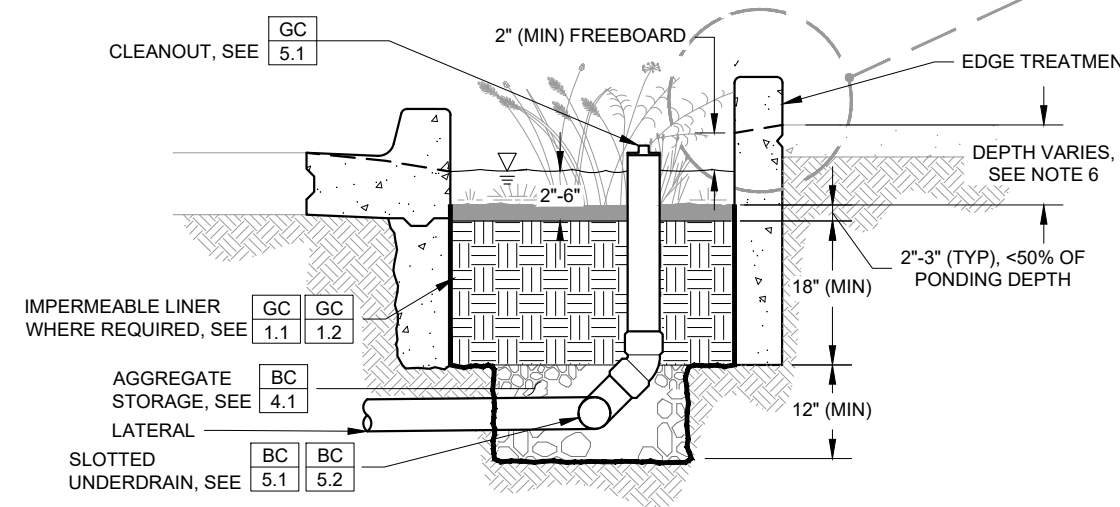

OFFLINE CONFIGURATION WITH UNDERDRAIN - ALTERNATIVE 2

BIORETENTION PLANTER WITHOUT PARKING

CONSTRUCTION NOTES:

1. AVOID COMPACTION OF EXISTING SUBGRADE BELOW PLANTER DURING CONSTRUCTION.
2. SCARIFY SUBGRADE TO A DEPTH OF 3 INCHES (MIN) IMMEDIATELY PRIOR TO PLACEMENT OF AGGREGATE STORAGE AND BIORETENTION SOIL MATERIAL.
3. MAXIMUM DROP FROM TOP OF CURB/WALL TO TOP OF BIORETENTION SOIL SHALL INCLUDE CONSIDERATIONS FOR BIORETENTION SOIL SETTLEMENT. 30" DROP REQUIRES GUARD RAIL.
4. SLOPE OF PLANTER WALL TO MATCH LONGITUDINAL SLOPE OF ADJACENT SURFACES.
5. SEE BC 3.4 FOR ONLINE CONFIGURATIONS WITH OVERFLOW STRUCTURE.
6. MAXIMUM DROP FROM TOP OF WALKING SURFACE TO TOP OF MULCH SHALL INCLUDE CONSIDERATIONS FOR SOIL SETTLEMENT.

ROADSIDE APPLICATIONS										PARCEL APPLICATIONS								
NOTES		W/PARKING		W/O PARKING		BULBOUT						NOTES		PLAN		SECTIONS		
BP 1.1	BP 1.2	BP 2.1	BP 2.2	BP 3.1	BP 3.2	BP 4.1	BP 4.2	BP 4.3	BP 4.4	BP 4.5	BP 4.6	BP 5.1	BP 5.2	BP 5.3	BP 5.4	BP 5.5	BP 5.6	BP 5.7



**GREEN INFRASTRUCTURE
TYPICAL DETAILS**

SAN FRANCISCO PUBLIC UTILITIES COMMISSION

DATE	JANUARY 2023
VERSION	3.0
REVISED	

**BIORETENTION PLANTER
ROADSIDE PLANTER WITHOUT PARKING
SECTIONS**

DWG NO.
**BP
3.2**

NOT FOR CONSTRUCTION - REFER TO USER GUIDE

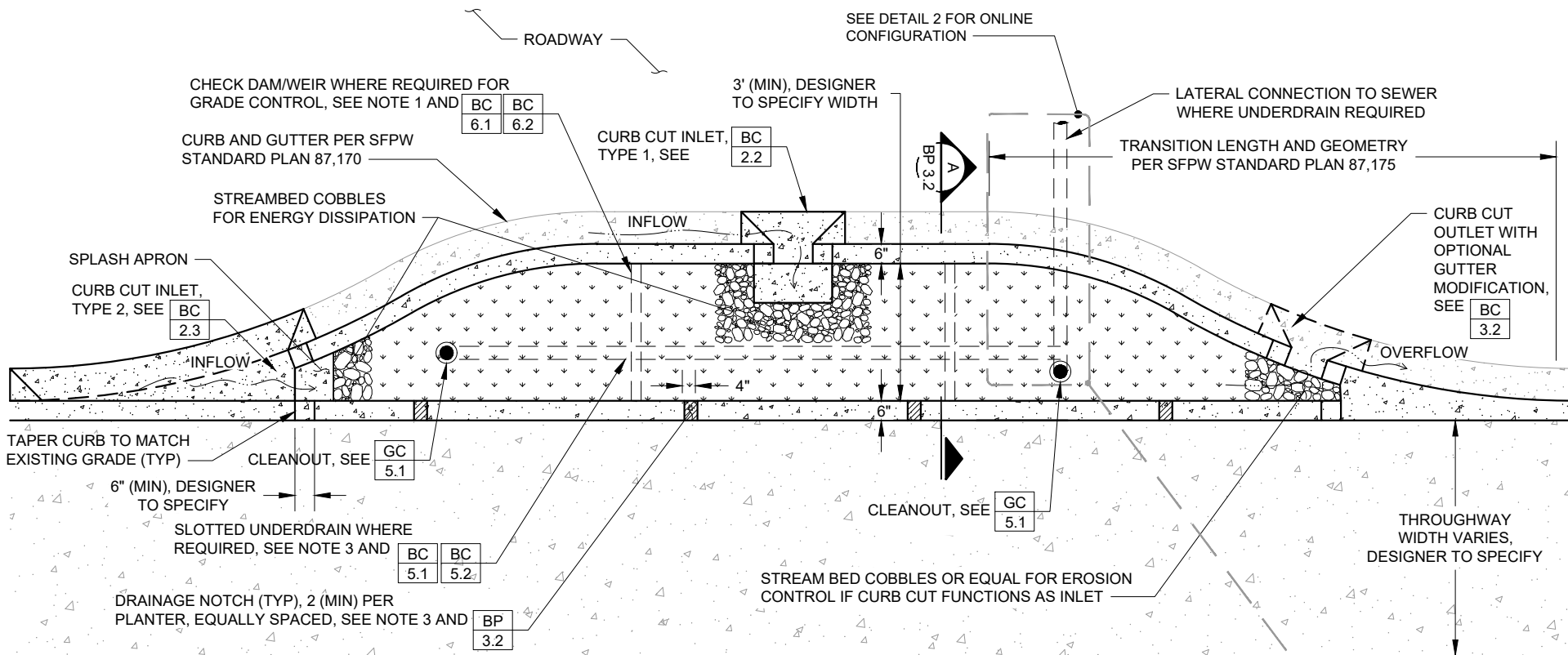

PLAN - OFFLINE CONFIGURATION 1

CONSTRUCTION NOTES:

1. CHECK DAMS SHALL BE SPACED TO PROVIDE PONDING PER SITE SPECIFIC DESIGN.
2. LAY OUT DRAINAGE NOTCHES TO PREVENT PONDING BEHIND PLANTER WALL WITH 5' MAXIMUM SPACING BETWEEN NOTCHES.
3. PROVIDE ONE CLEANOUT PER PLANTER (MIN) FOR FACILITIES WITH UNDERDRAINS.
4. MINIMUM UTILITY SETBACKS AND PROTECTION MEASURES MUST CONFORM TO CURRENT SFPUC ASSET PROTECTION STANDARDS. COORDINATE WITH ENGINEER IN THE EVENT OF UTILITY CROSSING AND UTILITY CONFLICTS.
5. PUBLIC ROW/SFPUC ASSETS: SHALL BE OFFLINE CONFIGURATION, SEE BP 1.1.
6. PRIVATE PARCEL: OFFLINE OR ONLINE CONFIGURATION ALLOWED.

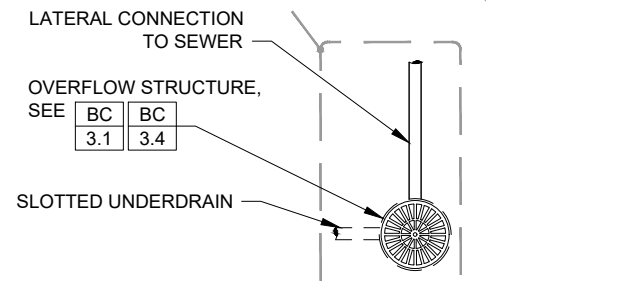

PLAN - ONLINE CONFIGURATION 2

ROADSIDE APPLICATIONS											PARCEL APPLICATIONS							
NOTES		W/PARKING		W/O PARKING		BULBOUT					NOTES		PLAN		SECTIONS			
BP 1.1	BP 1.2	BP 2.1	BP 2.2	BP 3.1	BP 3.2	BP 4.1	BP 4.2	BP 4.3	BP 4.4	BP 4.5	BP 4.6	BP 5.1	BP 5.2	BP 5.3	BP 5.4	BP 5.5	BP 5.6	BP 5.7



**GREEN INFRASTRUCTURE
TYPICAL DETAILS**
SAN FRANCISCO PUBLIC UTILITIES COMMISSION

DATE	JANUARY 2023
VERSION	3.0
REVISED	

**BIORETENTION PLANTER
ROADSIDE BULBOUT PLANTER
ALTERNATIVE 1**

DWG NO.

**BP
4.1**

NOT FOR CONSTRUCTION - REFER TO USER GUIDE

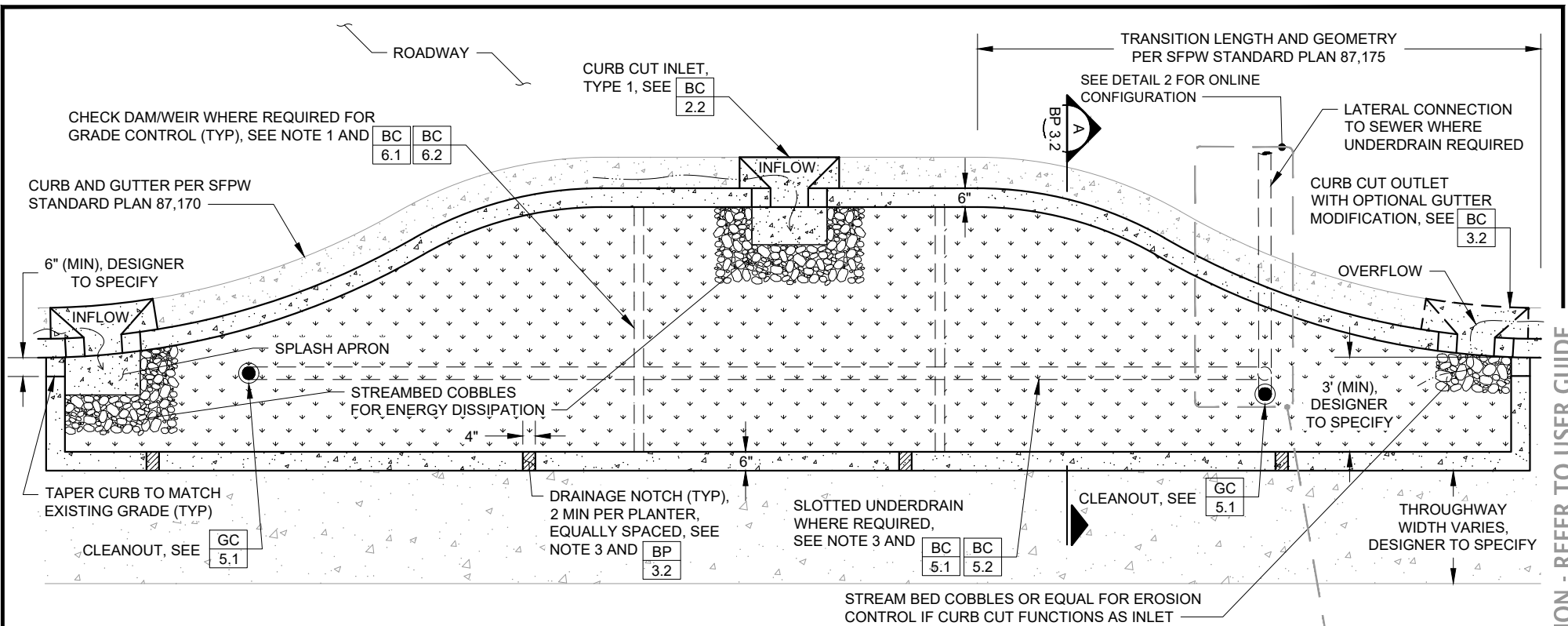

PLAN - OFFLINE CONFIGURATION 1

CONSTRUCTION NOTES:

1. CHECK DAMS SHALL BE SPACED TO PROVIDE PONDING PER SITE SPECIFIC DESIGN.
2. LAY OUT DRAINAGE NOTCHES TO PREVENT PONDING BEHIND PLANTER WALL WITH 5' MAXIMUM SPACING BETWEEN NOTCHES.
3. PROVIDE ONE CLEANOUT PER PLANTER (MIN) FOR FACILITIES WITH UNDERDRAINS.
4. MINIMUM UTILITY SETBACKS AND PROTECTION MEASURES MUST CONFORM TO CURRENT SFPUC ASSET PROTECTION STANDARDS. COORDINATE WITH ENGINEER IN THE EVENT OF UTILITY CROSSING AND UTILITY CONFLICTS.
5. PUBLIC ROW/SFPUC ASSETS: SHALL BE OFFLINE CONFIGURATION, SEE BP 1.1.
6. PRIVATE PARCEL: OFFLINE OR ONLINE CONFIGURATION ALLOWED.

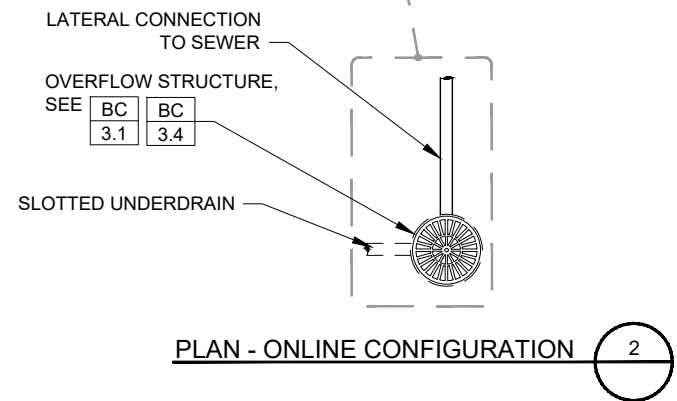

PLAN - ONLINE CONFIGURATION 2

ROADSIDE APPLICATIONS											PARCEL APPLICATIONS							
NOTES		W/PARKING		W/O PARKING		BULBOUT						NOTES		PLAN		SECTIONS		
BP 1.1	BP 1.2	BP 2.1	BP 2.2	BP 3.1	BP 3.2	BP 4.1	BP 4.2	BP 4.3	BP 4.4	BP 4.5	BP 4.6	BP 5.1	BP 5.2	BP 5.3	BP 5.4	BP 5.5	BP 5.6	BP 5.7



**GREEN INFRASTRUCTURE
TYPICAL DETAILS**
SAN FRANCISCO PUBLIC UTILITIES COMMISSION

DATE
JANUARY 2023
VERSION
3.0
REVISED

**BIORETENTION PLANTER
ROADSIDE BULBOUT PLANTER
ALTERNATIVE 2**

DWG NO.
**BP
4.2**

NOT FOR CONSTRUCTION - REFER TO USER GUIDE

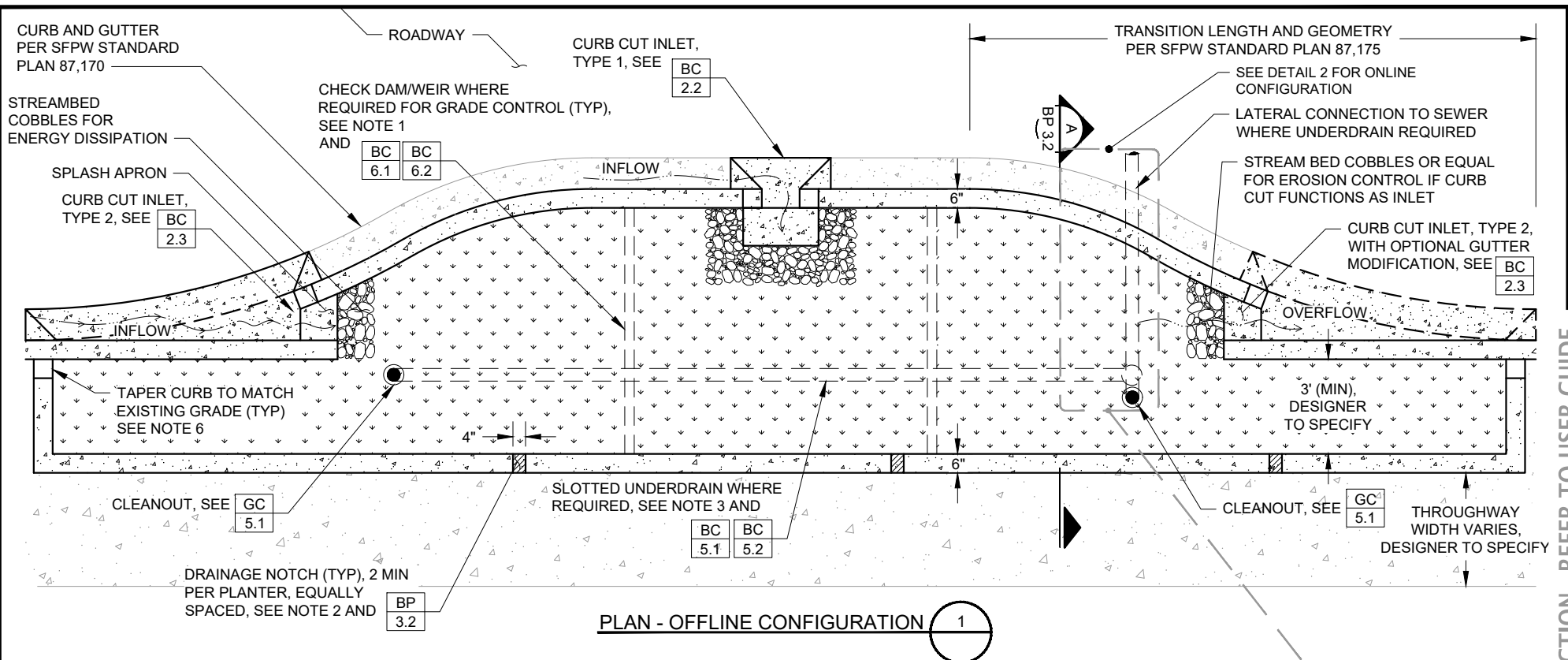

PLAN - OFFLINE CONFIGURATION 1

CONSTRUCTION NOTES:

1. CHECK DAMS SHALL BE SPACED TO PROVIDE PONDING PER SITE SPECIFIC DESIGN.
2. LAY OUT DRAINAGE NOTCHES TO PREVENT PONDING BEHIND PLANTER WALL WITH 5' MAXIMUM SPACING BETWEEN NOTCHES.
3. PROVIDE ONE CLEANOUT PER PLANTER (MIN) FOR FACILITIES WITH UNDERDRAINS.
4. MINIMUM UTILITY SETBACKS AND PROTECTION MEASURES MUST CONFORM TO CURRENT SFPUC ASSET PROTECTION STANDARDS. COORDINATE WITH ENGINEER IN THE EVENT OF UTILITY CROSSING AND UTILITY CONFLICTS.
5. IF STREET PARKING IS ALLOWED IMMEDIATELY ADJACENT TO THE CURB CUT INLET/OUTLET, THE PLANTER WALL TAPER SHOULD BE LOCATED 18" BEHIND THE FACE OF CURB. COORDINATE WITH SAN FRANCISCO PUBLIC WORKS.
6. PUBLIC ROW/SFPUC ASSETS: SHALL BE OFFLINE CONFIGURATION, SEE **BP 1.1**.
7. PRIVATE PARCEL: OFFLINE OR ONLINE CONFIGURATION ALLOWED.

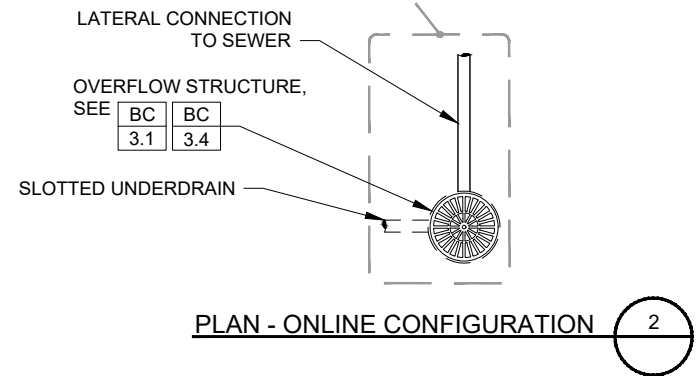

PLAN - ONLINE CONFIGURATION 2

ROADSIDE APPLICATIONS											PARCEL APPLICATIONS							
NOTES		W/PARKING		W/O PARKING		BULBOUT						NOTES		PLAN		SECTIONS		
BP 1.1	BP 1.2	BP 2.1	BP 2.2	BP 3.1	BP 3.2	BP 4.1	BP 4.2	BP 4.3	BP 4.4	BP 4.5	BP 4.6	BP 5.1	BP 5.2	BP 5.3	BP 5.4	BP 5.5	BP 5.6	BP 5.7



**GREEN INFRASTRUCTURE
TYPICAL DETAILS**
SAN FRANCISCO PUBLIC UTILITIES COMMISSION

DATE
JANUARY 2023
VERSION
3.0
REVISED

**BIORETENTION PLANTER
ROADSIDE BULBOUT PLANTER
ALTERNATIVE 3**

DWG NO.
**BP
4.3**

NOT FOR CONSTRUCTION - REFER TO USER GUIDE

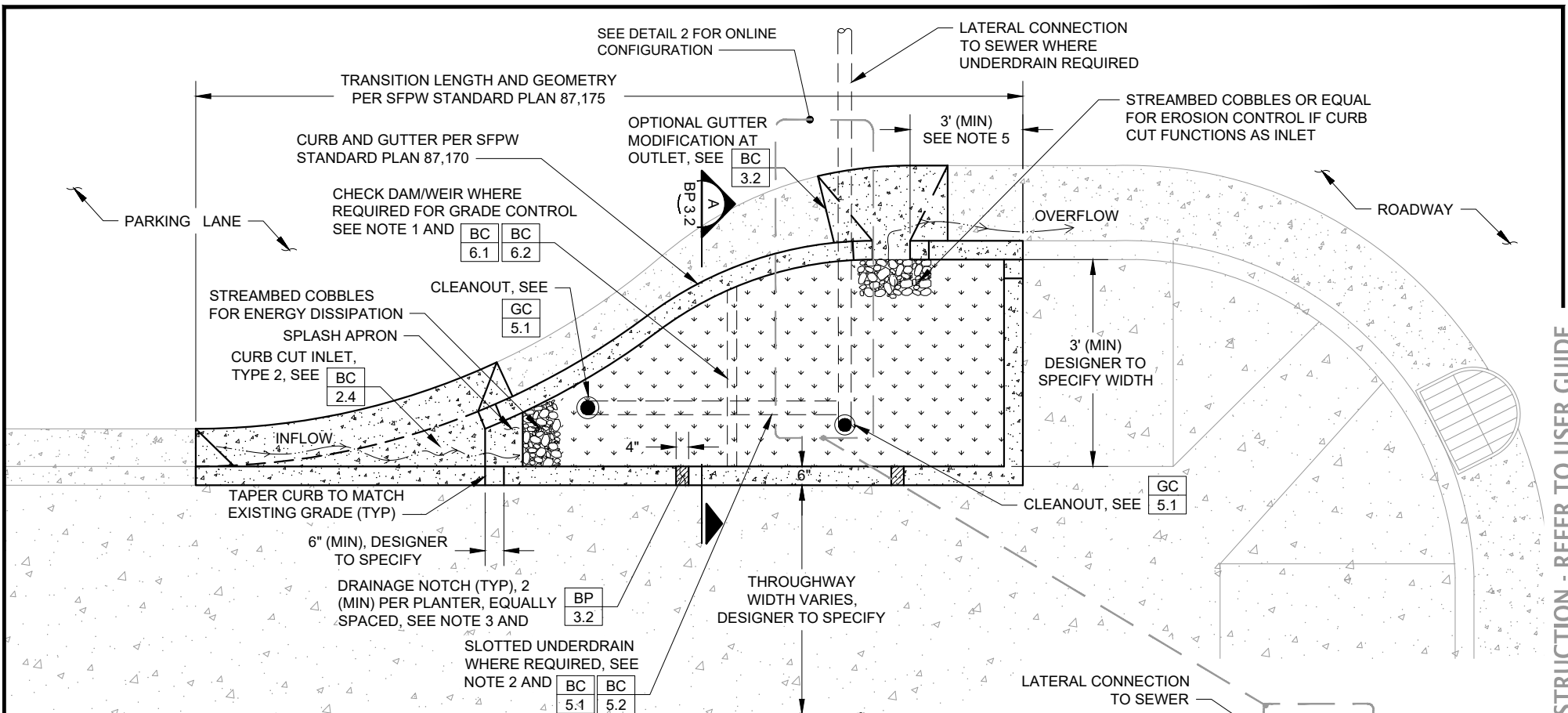

PLAN - OFFLINE CONFIGURATION 1

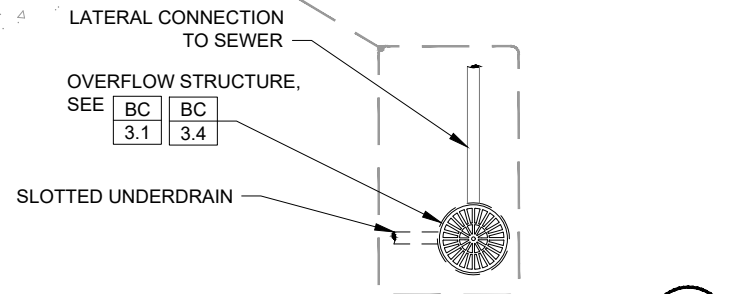

PLAN - ONLINE CONFIGURATION 2

CONSTRUCTION NOTES:

- CHECK DAMS SHALL BE SPACED TO PROVIDE PONDING PER SITE SPECIFIC DESIGN.
- LAY OUT DRAINAGE NOTCHES TO PREVENT PONDING BEHIND PLANTER WALL WITH 5' MAXIMUM SPACING BETWEEN NOTCHES.
- PROVIDE ONE CLEANOUT PER PLANTER (MIN) FOR FACILITIES WITH UNDERDRAINS.
- MINIMUM UTILITY SETBACKS AND PROTECTION MEASURES MUST CONFORM TO CURRENT SFPUC ASSET PROTECTION STANDARDS. COORDINATE WITH ENGINEER IN THE EVENT OF UTILITY CROSSING AND UTILITY CONFLICTS.
- PUBLIC ROW/ SFPUC ASSETS: SHALL BE OFFLINE CONFIGURATION. SEE BP1.1
- PRIVATE PARCEL: OFFLINE OR ONLINE CONFIGURATION ALLOWED

ROADSIDE APPLICATIONS											PARCEL APPLICATIONS							
NOTES		W/PARKING		W/O PARKING		BULBOUT						NOTES		PLAN		SECTIONS		
BP	BP	BP	BP	BP	BP	BP	BP	BP	BP	BP	BP	BP	BP	BP	BP	BP	BP	BP
1.1	1.2	2.1	2.2	3.1	3.2	4.1	4.2	4.3	4.4	4.5	4.6	5.1	5.2	5.3	5.4	5.5	5.6	5.7



**GREEN INFRASTRUCTURE
TYPICAL DETAILS**

SAN FRANCISCO PUBLIC UTILITIES COMMISSION

DATE
JANUARY 2023
VERSION
3.0
REVISED

**BIORETENTION PLANTER
ROADSIDE BULBOUT PLANTER
ALTERNATIVE 4**

DWG NO.
**BP
4.4**

NOT FOR CONSTRUCTION - REFER TO USER GUIDE

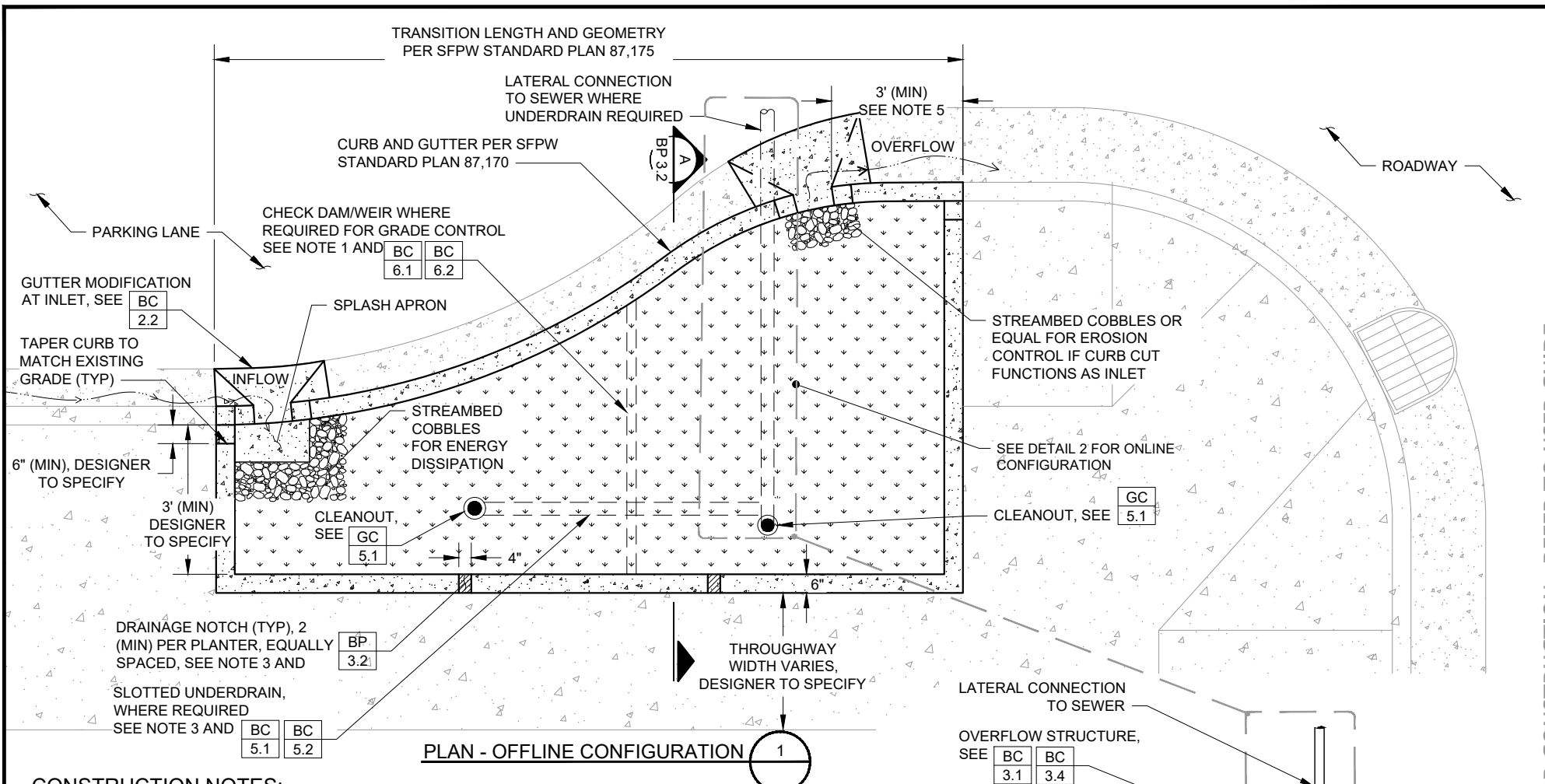

PLAN - OFFLINE CONFIGURATION 1

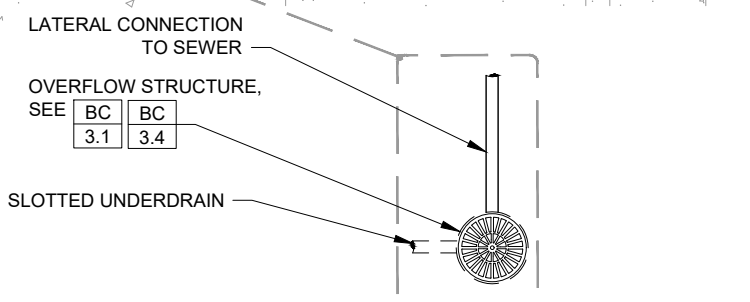

PLAN - ONLINE CONFIGURATION 2

CONSTRUCTION NOTES:

- CHECK DAMS SHALL BE SPACED TO PROVIDE PONDING PER SITE SPECIFIC DESIGN.
- LAY OUT DRAINAGE NOTCHES TO PREVENT PONDING BEHIND PLANTER WALL WITH 5' MAXIMUM SPACING BETWEEN NOTCHES.
- PROVIDE ONE CLEANOUT PER PLANTER (MIN) FOR FACILITIES WITH UNDERDRAINS.
- MINIMUM UTILITY SETBACKS AND PROTECTION MEASURES MUST CONFORM TO CURRENT SFPUC ASSET PROTECTION STANDARDS. COORDINATE WITH ENGINEER IN THE EVENT OF UTILITY CROSSING AND UTILITY CONFLICTS.
- PUBLIC ROW/ SFPUC ASSETS: SHALL BE OFFLINE CONFIGURATION. SEE BP1.1
- PRIVATE PARCEL: OFFLINE OR ONLINE CONFIGURATION ALLOWED

ROADSIDE APPLICATIONS										PARCEL APPLICATIONS								
NOTES		W/PARKING		W/O PARKING		BULBOUT				NOTES		PLAN		SECTIONS				
BP 1.1	BP 1.2	BP 2.1	BP 2.2	BP 3.1	BP 3.2	BP 4.1	BP 4.2	BP 4.3	BP 4.4	BP 4.5	BP 4.6	BP 5.1	BP 5.2	BP 5.3	BP 5.4	BP 5.5	BP 5.6	BP 5.7



**GREEN INFRASTRUCTURE
TYPICAL DETAILS**

SAN FRANCISCO PUBLIC UTILITIES COMMISSION

DATE	JANUARY 2023
VERSION	3.0
REVISED	

**BIORETENTION PLANTER
ROADSIDE BULBOUT PLANTER
ALTERNATIVE 5**

DWG NO.
**BP
4.5**

NOT FOR CONSTRUCTION - REFER TO USER GUIDE

TRANSITION LENGTH AND GEOMETRY
PER SFPW STANDARD PLAN 87,175

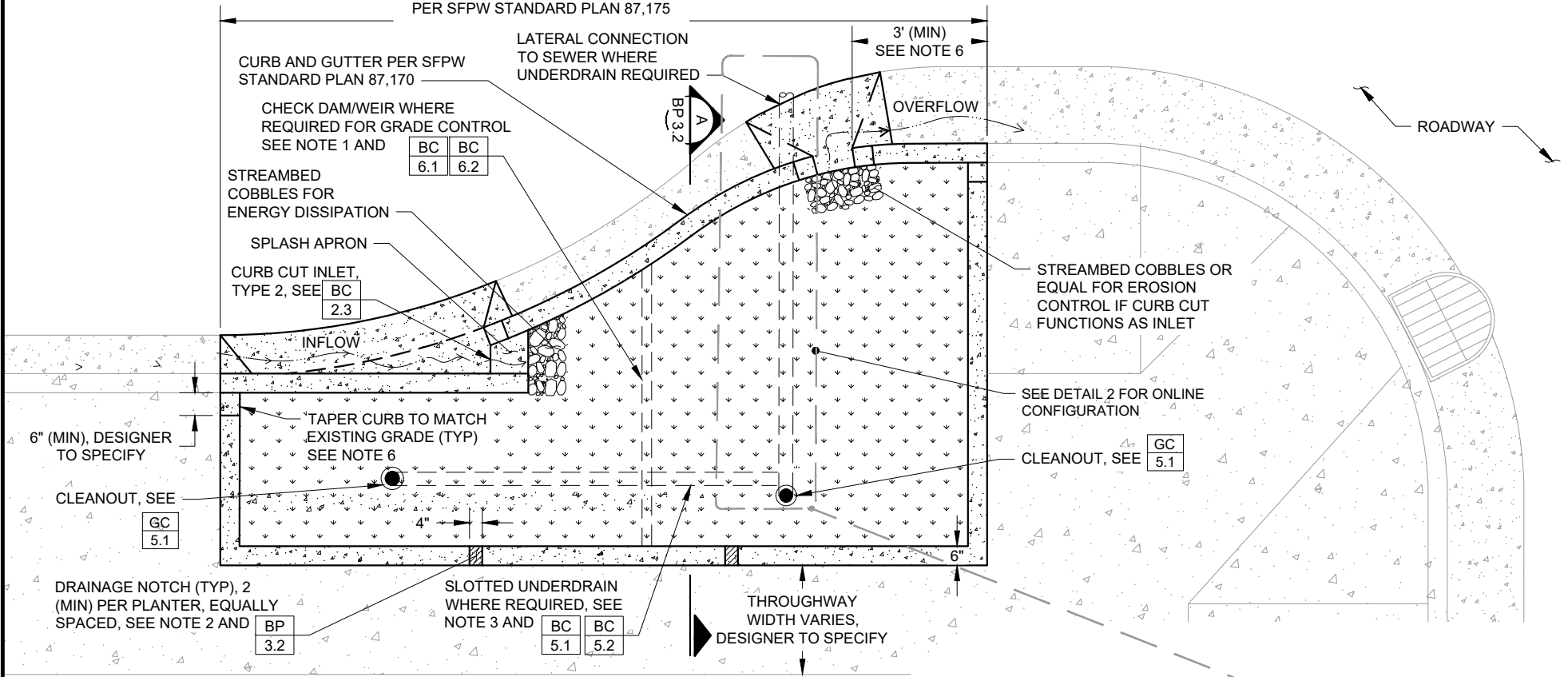

PLAN - OFFLINE CONFIGURATION 1

CONSTRUCTION NOTES:

- CHECK DAMS SHALL BE SPACED TO PROVIDE PONDING PER SITE SPECIFIC DESIGN.
- LAY OUT DRAINAGE NOTCHES TO PREVENT PONDING BEHIND PLANTER WALL WITH 5' MAXIMUM SPACING BETWEEN NOTCHES.
- PROVIDE ONE CLEANOUT PER PLANTER (MIN) FOR FACILITIES WITH UNDERDRAINS.
- MINIMUM UTILITY SETBACKS AND PROTECTION MEASURES MUST CONFORM TO CURRENT SFPUC ASSET PROTECTION STANDARDS. COORDINATE WITH ENGINEER IN THE EVENT OF UTILITY CROSSING AND UTILITY CONFLICTS.
- IF STREET PARKING IS ALLOWED IMMEDIATELY ADJACENT TO THE CURB CUT INLET/OUTLET, THE PLANTER WALL TAPER SHOULD BE LOCATED 18" BEHIND THE FACE OF CURB. COORDINATE WITH SAN FRANCISCO PUBLIC WORKS.
- PUBLIC ROW/ SFPUC ASSETS: SHALL BE OFFLINE CONFIGURATION. SEE BP1.1
- PRIVATE PARCEL: OFFLINE OR ONLINE CONFIGURATION ALLOWED

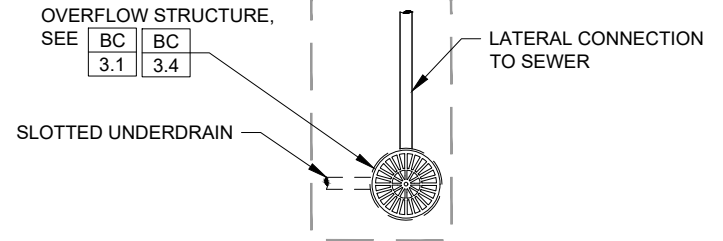

PLAN - ONLINE CONFIGURATION 2

ROADSIDE APPLICATIONS

PARCEL APPLICATIONS

NOTES		W/PARKING		W/O PARKING		BULBOUT					NOTES		PLAN		SECTIONS			
BP 1.1	BP 1.2	BP 2.1	BP 2.2	BP 3.1	BP 3.2	BP 4.1	BP 4.2	BP 4.3	BP 4.4	BP 4.5	BP 4.6	BP 5.1	BP 5.2	BP 5.3	BP 5.4	BP 5.5	BP 5.6	BP 5.7



**GREEN INFRASTRUCTURE
TYPICAL DETAILS**
SAN FRANCISCO PUBLIC UTILITIES COMMISSION

DATE
JANUARY 2023
VERSION
3.0
REVISED

**BIORETENTION PLANTER
ROADSIDE BULBOUT PLANTER
ALTERNATIVE 6**

DWG NO.
**BP
4.6**

NOT FOR CONSTRUCTION - REFER TO USER GUIDE

PURPOSE:

PARCEL BIORETENTION PLANTERS IN:

- CSS AREAS: CONTROL PEAK FLOWS AND VOLUMES OF STORMWATER RUNOFF BY PROVIDING SURFACE, SUBSURFACE STORAGE AND INFILTRATION INTO NATIVE SOIL;
- MS4 AREAS: REMOVE POLLUTANTS OF CONCERN AS WATER FILTERS THROUGH BIORETENTION SOIL.

DESIGNER NOTES & GUIDELINES:

1. THE DESIGNER MUST ADAPT PLAN AND SECTION DRAWINGS TO ADDRESS BUILDING- AND SITE-SPECIFIC CONDITIONS.
2. THE DESIGNER MUST COMPLY WITH ALL APPLICABLE SITE AND BUILDING CODE REQUIREMENTS FOR ON-SITE ACCESSIBILITY AND SAFETY INCLUDING, BUT NOT LIMITED TO, CURBS, PEDESTRIAN SURFACING, AND GUARDRAILS/FALL HEIGHTS.
3. PLANTER AREA, PONDING DEPTH, BIORETENTION SOIL DEPTH, AND AGGREGATE STORAGE DEPTH MUST BE SIZED TO MEET PROJECT-SPECIFIC PERFORMANCE GOALS.
4. PONDING AND BIORETENTION SOIL DRAWDOWN TIME (I.E., TIME FOR MAXIMUM SURFACE PONDING TO DRAIN THROUGH THE BIORETENTION SOIL AFTER THE END OF A STORM) RECOMMENDATIONS:
 - 3 - 12 HOUR DRAWDOWN FOR PONDING AND BIORETENTION SOIL (TYPICAL)
 - 24 HOUR MAXIMUM DRAWDOWN FOR PONDING AND BIORETENTION SOIL
5. FACILITY DRAWDOWN TIME (I.E., TIME FOR SURFACE PONDING TO DRAIN THROUGH THE ENTIRE SECTION INCLUDING AGGREGATE STORAGE AFTER THE END OF A STORM) REQUIREMENTS:
 - 48 HOUR MAXIMUM FACILITY DRAWDOWN (I.E., ORIFICE CONTROLLED SYSTEM OR EXTENDED STORAGE DEPTH WITHIN INFILTRATION SYSTEM)
6. AN AGGREGATE COURSE UNDER THE BIORETENTION SOIL IS REQUIRED FOR BIORETENTION IN SEPARATE SEWER SYSTEM. USE AGGREGATE COURSE WHERE REQUIRED (E.G., WITH UNDERDRAIN, FOR STORAGE, ETC.) FOR FACILITIES IN COMBINED SEWER SYSTEM AREAS.
7. CHECK DAMS OR WEIRS MAY BE USED TO TERRACE FACILITIES TO PROVIDE SUFFICIENT PONDING FOR HIGHER-SLOPED INSTALLATIONS. DESIGNER MUST SPECIFY CHECK DAM HEIGHT AND SPACING. REFER TO **BC 6.1** AND **BC 6.2** FOR GUIDANCE ON CHECK DAM DESIGN.
8. PLANTER OVERFLOW STRUCTURES SHALL BE DESIGNED TO CONVEY THE ANTICIPATED PEAK DESIGN FLOWS PER SAN FRANCISCO DBI REQUIREMENTS.
9. FOR BMPS ON BUILDING STRUCTURE, PASSIVE GRAVITY OVERFLOW FROM BMP IS REQUIRED EITHER BY OVERFLOW PIPING FROM BMP OR BY "FAILSAFE" BYPASS DIVERTER VALVE.
10. PLANTERS SHALL BE DESIGNED TO OVERFLOW TO THE STREET OR DRAIN AWAY FROM BUILDINGS (IF NOT ADJACENT TO THE STREET). DESIGNER TO CONSIDER ADDING OVERFLOW NOTCH TO DIRECT EMERGENCY OVERFLOW TO DRAIN.
11. MATERIALS FOR PLANTERS MUST BE WATER-TIGHT AND MAY VARY TO WORK WITH SITE AND ARCHITECTURAL PALETTE.
12. BUILDING SETBACKS SHALL CONFORM TO SMR APPENDIX C, TABLE C1.
13. FACILITIES MAY BE EXTENDED ABOVE GRADE FOR SEATWALL OR RAISED PLANTER CONFIGURATIONS, IF APPROPRIATE CONVEYANCE MEASURES ARE PROVIDED TO MEET DESIGN REQUIREMENTS.
14. CONVEYANCE CONNECTIONS MAY BE CONFIGURED TO ACCEPT RUNOFF VIA OVERHEAD CONVEYANCE (DOWNSPOUTS, OVERHEAD RUNNELS), SURFACE FLOW (CHANNELS), OR SUBSURFACE CONVEYANCE (PIPES, TRENCH DRAINS). REFER TO APPLICABLE SAN FRANCISCO DBI CODES FOR CONVEYANCE CONNECTION REQUIREMENTS.
15. CONVEYANCE CONNECTIONS (E.G. SCUPPER, CHANNEL, PIPE) SHALL BE SIZED TO ACCOMMODATE DRAINAGE FROM ROOF AREA WITH ADEQUATE FREEBOARD TO AVOID OVERFLOWING DURING PEAK FLOWS. REFER TO APPLICABLE SAN FRANCISCO DBI CODES FOR CONVEYANCE CONNECTION REQUIREMENTS.
16. UNDERDRAINS REQUIRED WHEN PLANTER IS LOCATED ON STRUCTURE TO DRAIN PLANTER AND AVOID ACCUMULATION OF WATER ON STRUCTURE WATERPROOFING SYSTEM
17. OVERFLOW STRUCTURE (MATERIAL AND WORKMANSHIP) SHALL CONFORM TO APPLICABLE SAN FRANCISCO DBI AND PUBLIC WORKS CODES AND REQUIREMENTS. SIZE AND MODEL OF ATRIUM GRATE AT OVERFLOW TO BE DETERMINED BY ENGINEER TO ENSURE CONVEYANCE OF PEAK FLOW WITH CONSIDERATION FOR RESTRICTED FLOW CAPACITY THROUGH ATRIUM GRATE.
18. THE DESIGNER MUST EVALUATE UTILITY SURVEYS FOR POTENTIAL UTILITY CROSSINGS OR CONFLICTS. REFER TO **GC 2.1 - GC 2.12** FOR UTILITY CROSSING DETAILS AND **GC 3.1 - GC 3.4** FOR UTILITY CONFLICT DETAILS.
19. REFER TO SAN FRANCISCO DBI CODES FOR CURB AND/OR RAILING REQUIREMENTS.
20. UNDERDRAIN LENGTHS SHALL BE SIZED FOR SUFFICIENT CAPACITY TO CONVEY THE PEAK FLOW TO THE BMP. THIS LENGTH SHALL BE BASED ON A CAPACITY OF 0.0047 CFS/LF.

NOT FOR CONSTRUCTION - REFER TO USER GUIDE

NOTES						ROADSIDE APPLICATIONS						PARCEL APPLICATIONS						
NOTES		W/PARKING		W/O PARKING		BULBOUT						NOTES		PLAN		SECTIONS		
BP 1.1	BP 1.2	BP 2.1	BP 2.2	BP 3.1	BP 3.2	BP 4.1	BP 4.2	BP 4.3	BP 4.4	BP 4.5	BP 4.6	BP 5.1	BP 5.2	BP 5.3	BP 5.4	BP 5.5	BP 5.6	BP 5.7



**GREEN INFRASTRUCTURE
TYPICAL DETAILS**
SAN FRANCISCO PUBLIC UTILITIES COMMISSION

DATE	JANUARY 2023
VERSION	3.0
REVISED	

**BIORETENTION PLANTER
PARCEL PLANTER
DESIGNER NOTES (1 OF 2)**

DWG. NO.
**BP
5.1**

LAYOUT REQUIREMENTS:

- DESIGNER MUST COMPLY WITH ALL CURRENT LOCAL CODES, INCLUDING BUT NOT LIMITED TO:
 - SAN FRANCISCO STORMWATER MANAGEMENT ORDINANCE
 - SAN FRANCISCO PLANNING CODE
 - CALIFORNIA BUILDING CODE
 - SAN FRANCISCO BUILDING CODE AMENDMENTS
 - ADA STANDARDS FOR ACCESSIBLE DESIGN
- PARCEL PLANTERS SHOULD NOT INTERFERE WITH OTHER LAND USE REQUIREMENTS SUCH AS BUFFERING AND SCREENING, SETBACKS, SIGHT DISTANCE, AND MINIMUM SITE COVERAGE.
- DESIGN ALL BMPS TO BE ACCESSIBLE FOR INSPECTIONS AND MAINTENANCE WITHOUT ACCESS THROUGH A TENANT RESIDENTIAL UNIT.
- INCORPORATE 'SAFETY BY DESIGN' INTO ALL ROOFTOP VEGETATED SYSTEMS TO ENSURE EASE OF ACCESS FOR MAINTENANCE AND INSPECTION. ADHERE TO APPLICABLE CAL-OSHA AND BUILDING CODES.
- CONSULTATION WITH A CALIFORNIA-REGISTERED STRUCTURAL ENGINEER IS RECOMMENDED TO EVALUATE LOAD-BEARING CAPACITY FOR COMPLIANCE WITH BUILDING CODE REQUIREMENTS.
- REFER TO **SHEET GEN 0.2** AND APPENDIX C OF THE STORMWATER MANAGEMENT REQUIREMENTS FOR MORE DETAILED INFORMATION ON SITING AND DESIGN REQUIREMENTS FOR INFILTRATION-BASED BMPS.

DESIGNER CHECKLIST (MUST SPECIFY, AS APPLICABLE):

- PLANTER WIDTH AND LENGTH
- DEPTH OF PONDING
- DEPTH OF FREEBOARD
- DEPTH OF BIORETENTION SOIL
- DEPTH AND TYPE OF AGGREGATE STORAGE, IF ANY
- PLANTER SURFACE ELEVATION (TOP OF BIORETENTION SOIL) AT UPSLOPE AND DOWNSLOPE ENDS OF FACILITY (I.E., PROVIDE SPOTS AND/OR CONTOURS AS NEEDED)
- CONTROL POINTS AT EVERY PLANTER WALL CORNER OR POINT OF TANGENCY
- DIMENSIONS AND DISTANCE TO EVERY INLET, OUTLET, CHECK DAM, WEIR, SIDEWALK NOTCH, ETC.
- ELEVATIONS OF EVERY INLET, OUTLET, STRUCTURE RIM AND INVERT, CLEAN OUT, PLANTER WALL CORNER, AND SIDEWALK NOTCH
- TYPE AND DESIGN OF PLANTER COMPONENTS (E.G., EDGE TREATMENTS, INLETS/GUTTER MODIFICATIONS, UTILITY CROSSINGS, LINER SPECIFICATION/DETAIL, AND PLANTING DETAILS)
- OVERFLOW STRUCTURE SIZE/DIAMETER (NOTE: OVERFLOW STRUCTURES SHALL BE SIZED TO CONVEY CONTRIBUTING AREA PEAK FLOW PER APPLICABLE BUILDING CODE, AND ALSO CONSIDER MAINTENANCE ACCESS, COMPATIBLE GRATE SIZES, AND GENERAL AESTHETICS.)
- OVERFLOW STRUCTURE ATRIUM GRATE SIZE, MODEL NUMBER, AND FLOW CAPACITY PER MANUFACTURER PRODUCT SHEET (NOTE: ATRIUM GRATE SHALL BE SIZED TO CONVEY CONTRIBUTING AREA PEAK FLOW PER APPLICABLE BUILDING CODE, WITH 4-INCH MIN.)
- OVERFLOW STRUCTURE/RISER SLAB PENETRATION DETAIL PER PLUMBING
- INLET STRUCTURES INCLUDING FITTINGS, SCUPPERS, ETC. FLOW DISTRIBUTION REQUIRED FOR EXCESSIVELY LONG OR LINEAR PLANTERS
- MINIMUM UNDERDRAIN LENGTH TO CONVEY PEAK FLOW TO BMP

RELATED COMPONENTS	
EDGE TREATMENTS:	BC 1.1 - BC 1.7
INLETS:	BC 2.1 - BC 2.4
OUTLETS:	BC 3.1 - BC 3.4
AGGREGATE STORAGE:	BC 4.1
UNDERDRAINS:	BC 5.1 - BC 5.2
CHECK DAMS:	BC 6.1 - BC 6.2
LINERS:	GC 1.1 - GC 1.2
UTILITY CROSSINGS:	GC 2.1 - GC 2.12
UTILITY CONFLICTS:	GC 2.1 - GC 3.4
OBSERVATION PORTS:	GC 4.1 - GC 4.3
CLEANOUTS:	GC 5.1

RELATED SPECIFICATIONS	CSI NO.
BIORETENTION: - BIORETENTION SOIL MIX - AGGREGATE STORAGE - MULCH - STREAMBED COBBLES	33 47 27

ROADSIDE APPLICATIONS												PARCEL APPLICATIONS						
NOTES		W/PARKING		W/O PARKING		BULBOUT						NOTES		PLAN		SECTIONS		
BP 1.1	BP 1.2	BP 2.1	BP 2.2	BP 3.1	BP 3.2	BP 4.1	BP 4.2	BP 4.3	BP 4.4	BP 4.5	BP 4.6	BP 5.1	BP 5.2	BP 5.3	BP 5.4	BP 5.5	BP 5.6	BP 5.7



**GREEN INFRASTRUCTURE
TYPICAL DETAILS**
SAN FRANCISCO PUBLIC UTILITIES COMMISSION

DATE	JANUARY 2023
VERSION	3.0
REVISED	

**BIORETENTION PLANTER
PARCEL PLANTER
DESIGNER NOTES (2 OF 2)**

DWG NO.
**BP
5.2**

NOT FOR CONSTRUCTION - REFER TO USER GUIDE

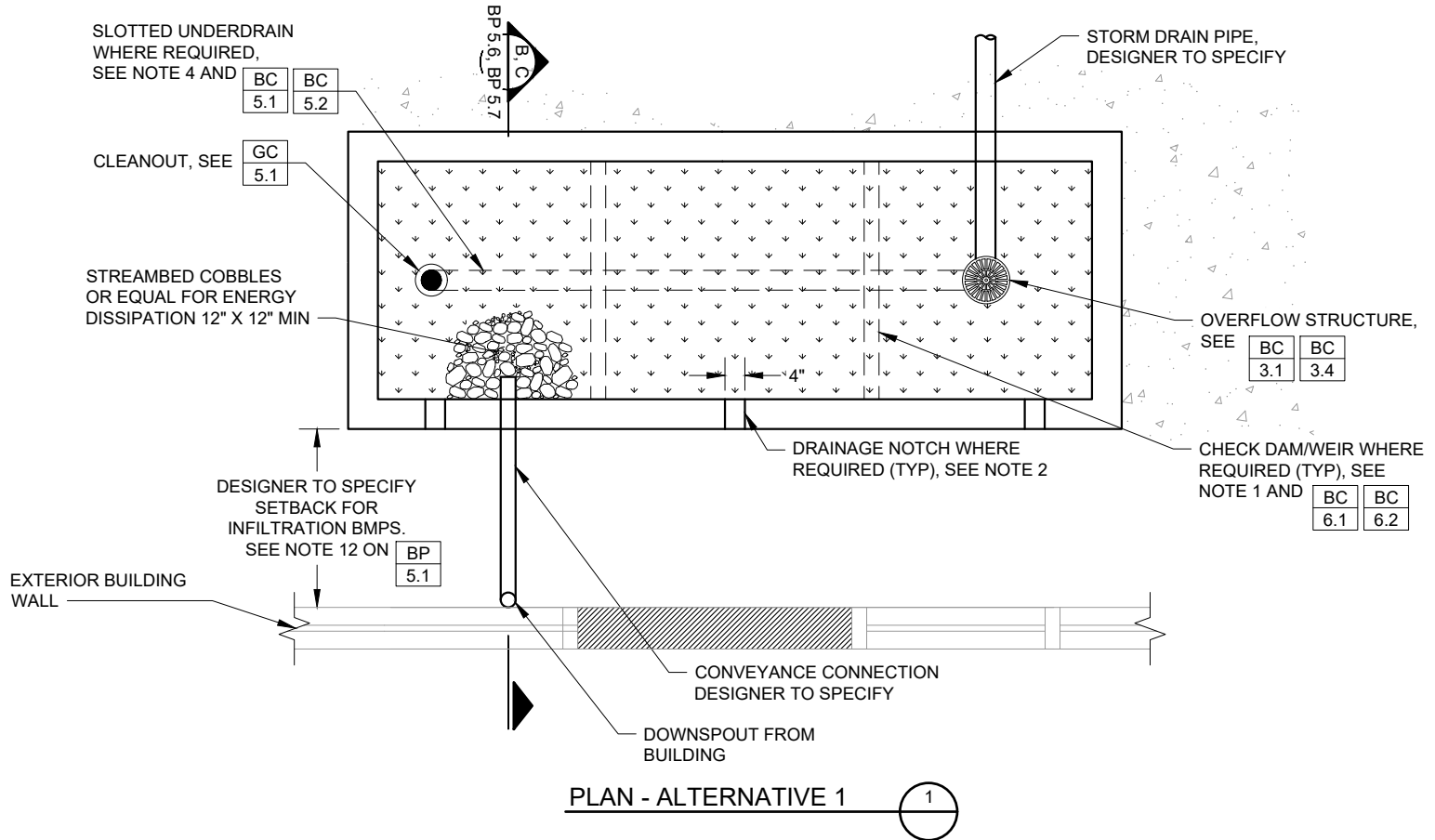

CONSTRUCTION NOTES:

1. CHECK DAMS/WEIRS SHALL BE SPACED TO PROVIDE PONDING PER SITE SPECIFIC DESIGN.
2. LAY OUT DRAINAGE NOTCHES TO PREVENT PONDING BEHIND PLANTER WALL WITH 5' MAXIMUM SPACING BETWEEN NOTCHES.
3. WATERPROOFING AND/OR LINER SYSTEM TO BE DESIGNED AND INSTALLED BY A WATERPROOFING PROFESSIONAL.
4. PROVIDE ONE CLEANOUT PER PLANTER (MIN) FOR FACILITIES WITH UNDERDRAINS.
5. MINIMUM UTILITY SETBACKS AND PROTECTION MEASURES MUST CONFORM TO CURRENT SFPUC ASSET PROTECTION STANDARDS. COORDINATE WITH ENGINEER IN THE EVENT OF UTILITY CROSSING AND UTILITY CONFLICTS.
6. PUBLIC ROW/SFPUC ASSETS: SHALL BE OFFLINE CONFIGURATION. SEE BP1.1.
7. PRIVATE PARCEL: OFFLINE OR ONLINE CONFIGURATION ALLOWED.

ROADSIDE APPLICATIONS												PARCEL APPLICATIONS						
NOTES		W/PARKING		W/O PARKING		BULBOUT						NOTES		PLAN		SECTIONS		
BP 1.1	BP 1.2	BP 2.1	BP 2.2	BP 3.1	BP 3.2	BP 4.1	BP 4.2	BP 4.3	BP 4.4	BP 4.5	BP 4.6	BP 5.1	BP 5.2	BP 5.3	BP 5.4	BP 5.5	BP 5.6	BP 5.7



**GREEN INFRASTRUCTURE
TYPICAL DETAILS**
SAN FRANCISCO PUBLIC UTILITIES COMMISSION

DATE
JANUARY 2023
VERSION
3.0
REVISED

**BIORETENTION PLANTER
PARCEL PLANTER PLAN
ALTERNATIVE 1**

DWG NO.
**BP
5.3**

NOT FOR CONSTRUCTION - REFER TO USER GUIDE

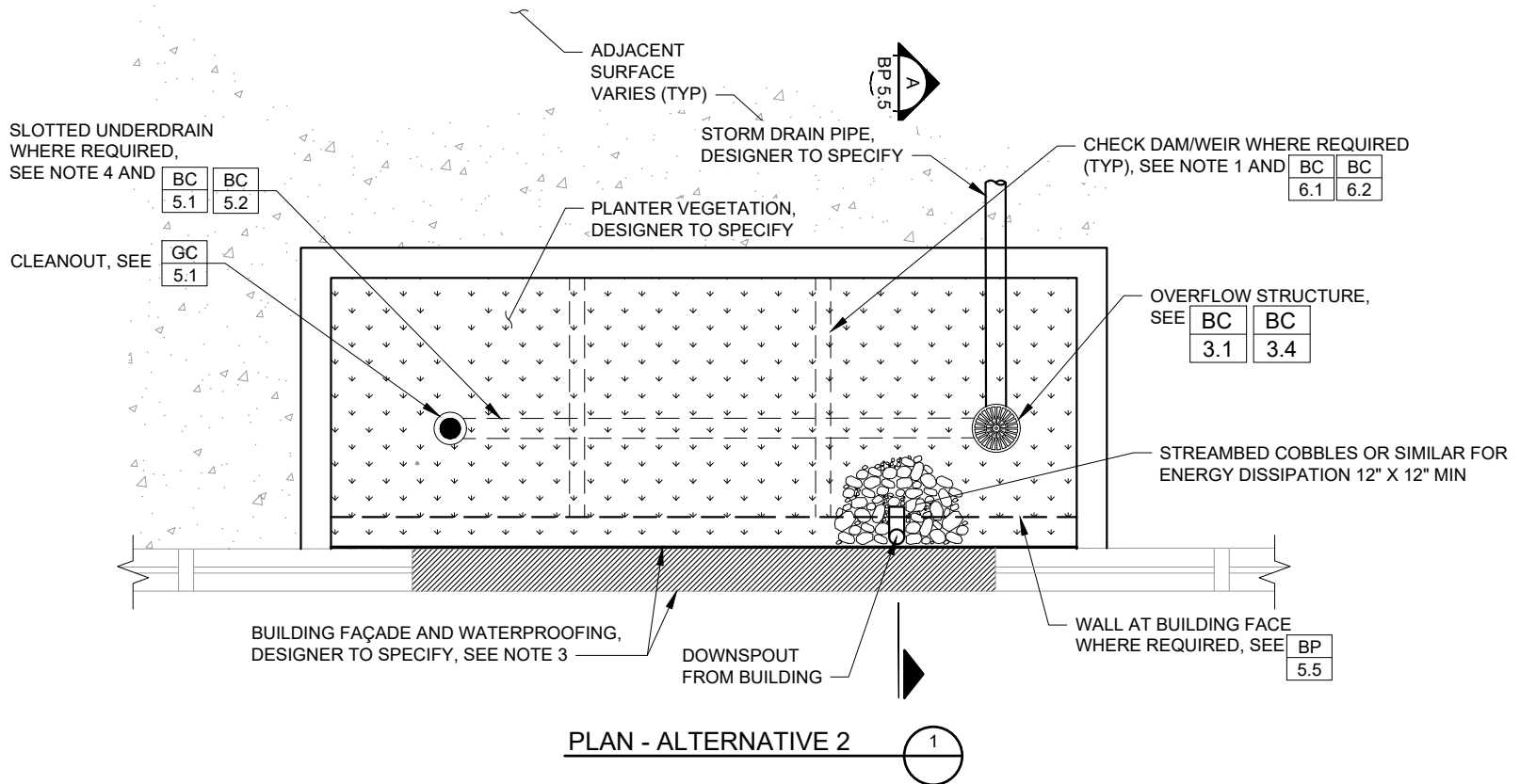

PLAN - ALTERNATIVE 2 1

CONSTRUCTION NOTES:

1. CHECK DAMS/WEIRS SHALL BE SPACED TO PROVIDE PONDING PER SITE SPECIFIC DESIGN.
2. LAY OUT DRAINAGE NOTCHES TO PREVENT PONDING BEHIND PLANTER WALL WITH 5' MAXIMUM SPACING BETWEEN NOTCHES.
3. WATERPROOFING AND/OR LINER SYSTEM TO BE DESIGNED AND INSTALLED BY A WATERPROOFING PROFESSIONAL.
4. PROVIDE ONE CLEANOUT PER PLANTER (MIN) FOR FACILITIES WITH UNDERDRAINS.
5. MINIMUM UTILITY SETBACKS AND PROTECTION MEASURES MUST CONFORM TO CURRENT SFPUC ASSET PROTECTION STANDARDS. COORDINATE WITH ENGINEER IN THE EVENT OF UTILITY CROSSING AND UTILITY CONFLICTS.
6. PUBLIC ROW/SFPUC ASSETS: SHALL BE OFFLINE CONFIGURATION. SEE BP1.1.
7. PRIVATE PARCEL: OFFLINE OR ONLINE CONFIGURATION ALLOWED.

ROADSIDE APPLICATIONS												PARCEL APPLICATIONS						
NOTES		W/PARKING		W/O PARKING		BULBOUT						NOTES		PLAN		SECTIONS		
BP 1.1	BP 1.2	BP 2.1	BP 2.2	BP 3.1	BP 3.2	BP 4.1	BP 4.2	BP 4.3	BP 4.4	BP 4.5	BP 4.6	BP 5.1	BP 5.2	BP 5.3	BP 5.4	BP 5.5	BP 5.6	BP 5.7



**GREEN INFRASTRUCTURE
TYPICAL DETAILS**
SAN FRANCISCO PUBLIC UTILITIES COMMISSION

DATE
JANUARY 2023
VERSION
3.0
REVISED

**BIORETENTION PLANTER
PARCEL PLANTER PLAN
ALTERNATIVE 2**

DWG NO.
**BP
5.4**

NOT FOR CONSTRUCTION - REFER TO USER GUIDE

CONSTRUCTION NOTES:

1. INSTALL DOWNSPOUTS OR OTHER CONVEYANCE CONNECTIONS (E.G. SCUPPER, CHANNEL, OVERHEAD RUNNEL) FROM BUILDING TO DRAIN ABOVE DESIGN PONDING ELEVATION. REFER TO APPLICABLE SAN FRANCISCO DBI CODES FOR CONVEYANCE CONNECTION REQUIREMENTS.
2. BUILDING WATERPROOFING BY ARCHITECT; COORDINATE PLANTER CONSTRUCTION WITH BUILDING FAÇADE / WATERPROOFING.
3. PROVIDE WALL AT BUILDING FACE IN CASES WHERE GAP IS REQUIRED BETWEEN WALL AND PLANTER OR WHERE BUILDING FAÇADE IS INCOMPATIBLE WITH PLANTER CONFIGURATION.
4. OVERFLOW STRUCTURE (MATERIAL AND WORKMANSHIP) SHALL CONFORM TO APPLICABLE SAN FRANCISCO DBI AND PUBLIC WORKS CODES AND REQUIREMENTS.
5. IF CONSTRUCTED OF PRECAST OR FABRICATED SECTIONS, PLANTER BOXES SHALL HAVE THEIR JOINTS SEALED WITH BUTYL RUBBER TAPE WHEN PRECAST PIECES ARE BEING SET. APPLYING ONLY MORTAR AND/OR NON-SHRINK GROUT TO UNSEALED JOINTS AFTER INSTALLATION IS NOT AN ACCEPTABLE MEANS OF WATERPROOFING THE PLANTER BOX.
6. OVERFLOW RISER, FITTINGS, SLOTTED UNDERDRAIN, AND CLEANOUT PIPE SHALL BE OF SAME MATERIAL.
7. OVERFLOW ATRIUM GRATE MUST BE MECHANICALLY FASTENED TO RISER WITH NON-CORROSIVE MATERIAL.
8. 6" PONDING DEPTH RECOMMENDED, 12" WITH SFPUC APPROVAL FOR FACILITIES ON GRADE.

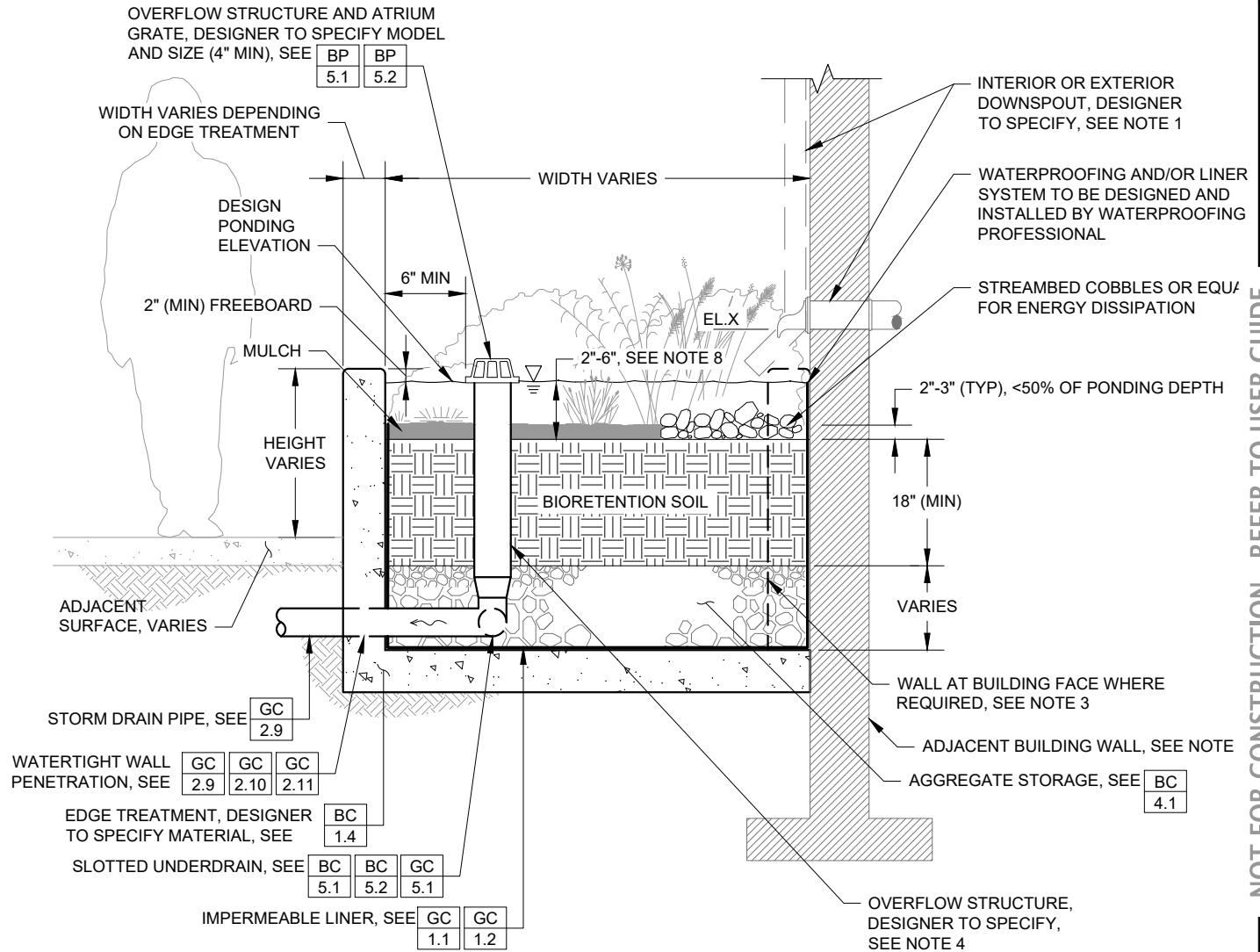

SECTION - RAISED BIORETENTION PLANTER A

ROADSIDE APPLICATIONS											PARCEL APPLICATIONS																																										
NOTES		W/PARKING		W/O PARKING		BULBOUT						NOTES		PLAN		SECTIONS																																					
<table border="1"><tr><td>BP</td><td>BP</td></tr><tr><td>1.1</td><td>1.2</td></tr></table>	BP	BP	1.1	1.2	<table border="1"><tr><td>BP</td><td>BP</td></tr><tr><td>2.1</td><td>2.2</td></tr></table>	BP	BP	2.1	2.2	<table border="1"><tr><td>BP</td><td>BP</td></tr><tr><td>3.1</td><td>3.2</td></tr></table>	BP	BP	3.1	3.2	<table border="1"><tr><td>BP</td><td>BP</td><td>BP</td><td>BP</td><td>BP</td><td>BP</td></tr><tr><td>4.1</td><td>4.2</td><td>4.3</td><td>4.4</td><td>4.5</td><td>4.6</td></tr></table>	BP	BP	BP	BP	BP	BP	4.1	4.2	4.3	4.4	4.5	4.6	<table border="1"><tr><td>BP</td><td>BP</td></tr><tr><td>5.1</td><td>5.2</td></tr></table>	BP	BP	5.1	5.2	<table border="1"><tr><td>BP</td><td>BP</td></tr><tr><td>5.3</td><td>5.4</td></tr></table>	BP	BP	5.3	5.4	<table border="1"><tr><td>BP</td><td>BP</td><td>BP</td></tr><tr><td>5.5</td><td>5.6</td><td>5.7</td></tr></table>	BP	BP	BP	5.5	5.6	5.7									
BP	BP																																																				
1.1	1.2																																																				
BP	BP																																																				
2.1	2.2																																																				
BP	BP																																																				
3.1	3.2																																																				
BP	BP	BP	BP	BP	BP																																																
4.1	4.2	4.3	4.4	4.5	4.6																																																
BP	BP																																																				
5.1	5.2																																																				
BP	BP																																																				
5.3	5.4																																																				
BP	BP	BP																																																			
5.5	5.6	5.7																																																			



**GREEN INFRASTRUCTURE
TYPICAL DETAILS**
SAN FRANCISCO PUBLIC UTILITIES COMMISSION

DATE	JANUARY 2023
VERSION	3.0
REVISED	

BIORETENTION PLANTER
PARCEL PLANTER
RAISED PLANTER SECTION

DWG NO.
**BP
5.5**

NOT FOR CONSTRUCTION - REFER TO USER GUIDE

CONSTRUCTION NOTES:

1. INSTALL DOWNSPOUTS AND OTHER CONVEYANCE CONNECTIONS (E.G. SCUPPER, CHANNEL, OVERHEAD RUNNEL, TRENCH DRAIN) FROM BUILDING TO DRAIN ABOVE DESIGN PONDING ELEVATION. REFER TO APPLICABLE SAN FRANCISCO DBI CODES FOR CONVEYANCE CONNECTION REQUIREMENTS. INCLUDE CLEANOUT AT DOWNPIPE CONNECTION FOR HORIZONTAL PIPE CONVEYANCE.
2. AVOID COMPACTION OF EXISTING SUBGRADE BELOW PLANTER FOR INFILTRATION FACILITIES.
3. SCARIFY SUBGRADE TO A DEPTH OF 3 INCHES (MIN) IMMEDIATELY PRIOR TO PLACEMENT OF AGGREGATE STORAGE AND BIORETENTION SOIL MATERIALS.
4. UNDERDRAIN AND LINER REQUIRED WITHIN 10 FEET OF BUILDING ENVELOPE UNLESS APPROVED PER DESIGNER.
5. MAXIMUM DROP FROM TOP OF WALKING SURFACE TO TOP OF MULCH SHALL INCLUDE CONSIDERATIONS FOR SOIL SETTLEMENT.
6. LAY OUT DRAINAGE NOTCHES TO PREVENT PONDING BEHIND PLANTER WALL. SLOPE NOTCHES TO DRAIN TO PLANTER.
7. OVERFLOW STRUCTURE (MATERIAL AND WORKMANSHIP) SHALL CONFORM TO APPLICABLE SAN FRANCISCO DBI AND PUBLIC WORKS CODES AND REQUIREMENTS.
8. IF CONSTRUCTED OF PRECAST OR FABRICATED, PLANTER BOXES SHALL HAVE THEIR JOINTS SEALED WITH BUTYL RUBBER TAPE WHEN PRECAST PIECES ARE BEING SET. APPLYING ONLY MORTAR AND/OR NON-SHRINK GROUT TO UNSEALED JOINTS AFTER INSTALLATION IS NOT AN ACCEPTABLE MEANS OF WATERPROOFING THE PLANTER BOX.
9. OVERFLOW RISER, FITTINGS, SLOTTED UNDERDRAIN, AND CLEANOUT PIPE SHALL BE OF SAME MATERIAL.
10. OVERFLOW ATRIUM GRATE MUST BE MECHANICALLY FASTENED TO RISER WITH NON-CORROSIVE MATERIAL.

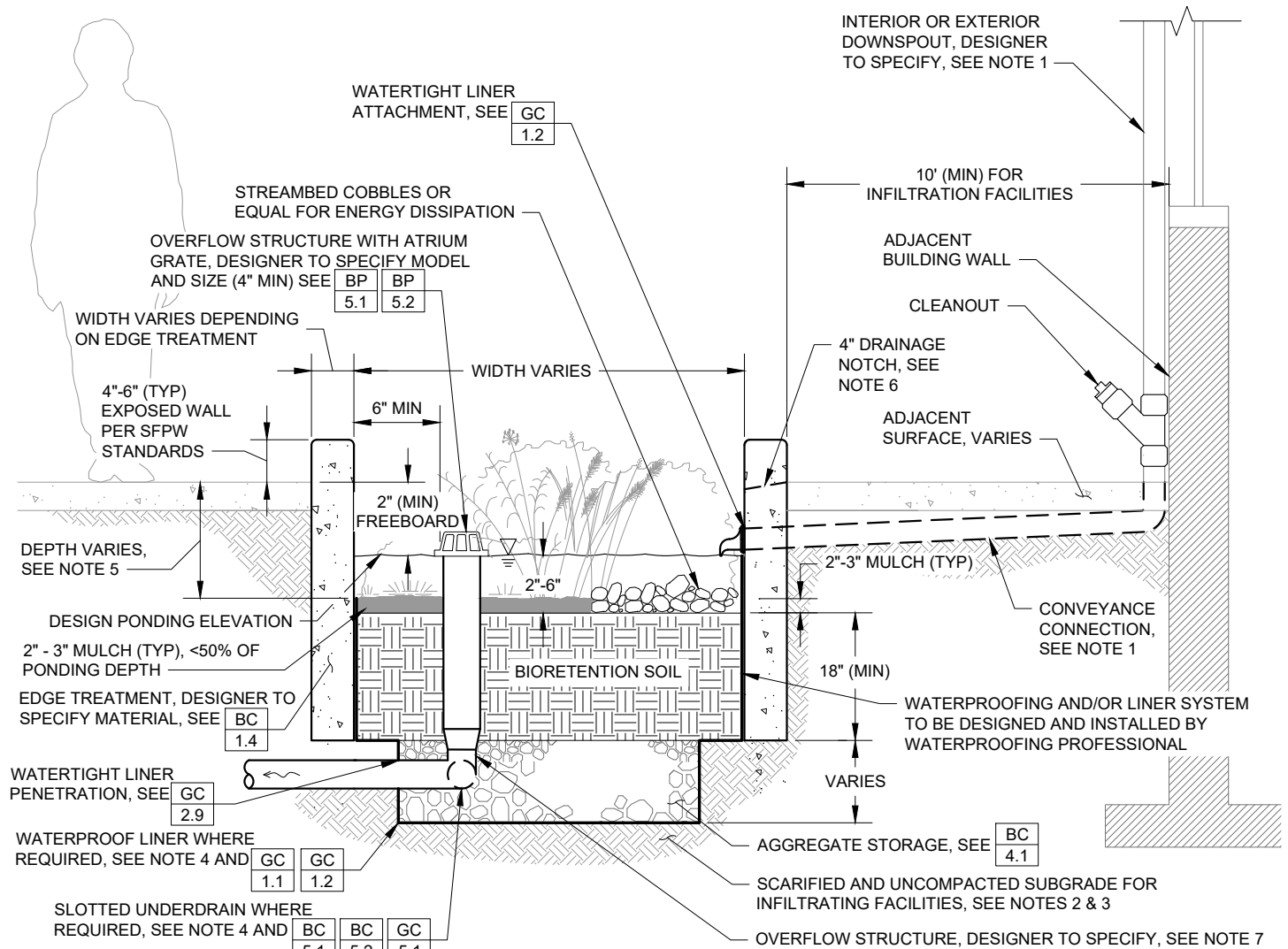

SECTION - SURFACE BIORETENTION PLANTER (B)

ROADSIDE APPLICATIONS										PARCEL APPLICATIONS								
NOTES		W/PARKING		W/O PARKING		BULBOUT						NOTES		PLAN		SECTIONS		
BP 1.1	BP 1.2	BP 2.1	BP 2.2	BP 3.1	BP 3.2	BP 4.1	BP 4.2	BP 4.3	BP 4.4	BP 4.5	BP 4.6	BP 5.1	BP 5.2	BP 5.3	BP 5.4	BP 5.5	BP 5.6	BP 5.7



**GREEN INFRASTRUCTURE
TYPICAL DETAILS**
SAN FRANCISCO PUBLIC UTILITIES COMMISSION

DATE	JANUARY 2023
VERSION	3.0
REVISED	

**BIORETENTION PLANTER
PARCEL PLANTER
AT-GRADE PLANTER SECTION**

DWG NO.
BP 5.6

NOT FOR CONSTRUCTION - REFER TO USER GUIDE

CONSTRUCTION NOTES:

1. INTEGRATE WATERPROOFING WITH BUILDING ROOFING/WATERPROOFING SYSTEMS INCLUDING WATERPROOF PIPE PENETRATIONS, JOINTS, AND LINER CONNECTIONS.
2. OVERFLOW STRUCTURE (MATERIAL AND WORKMANSHIP) SHALL CONFORM TO APPLICABLE SAN FRANCISCO DBI AND PUBLIC WORKS CODES AND REQUIREMENTS.
3. IF CONSTRUCTED OF PRECAST OR PREFABRICATED SECTIONS, PLANTER BOXES SHALL HAVE THEIR JOINTS SEALED WITH BUTYL RUBBER TAPE WHEN PRECAST PIECES ARE SET. APPLYING ONLY MORTAR AND/OR NON-SHRINK GROUT IS NOT AN ACCEPTABLE MEANS OF WATERPROOFING THE PLANTER BOX.
4. OVERFLOW RISER, FITTINGS, SLOTTED UNDERDRAIN, AND CLEANOUT PIPE SHALL BE OF SAME MATERIAL.
5. OVERFLOW ATRIUM GRATE MUST BE MECHANICALLY FASTENED TO RISER WITH NON-CORROSIVE MATERIAL.

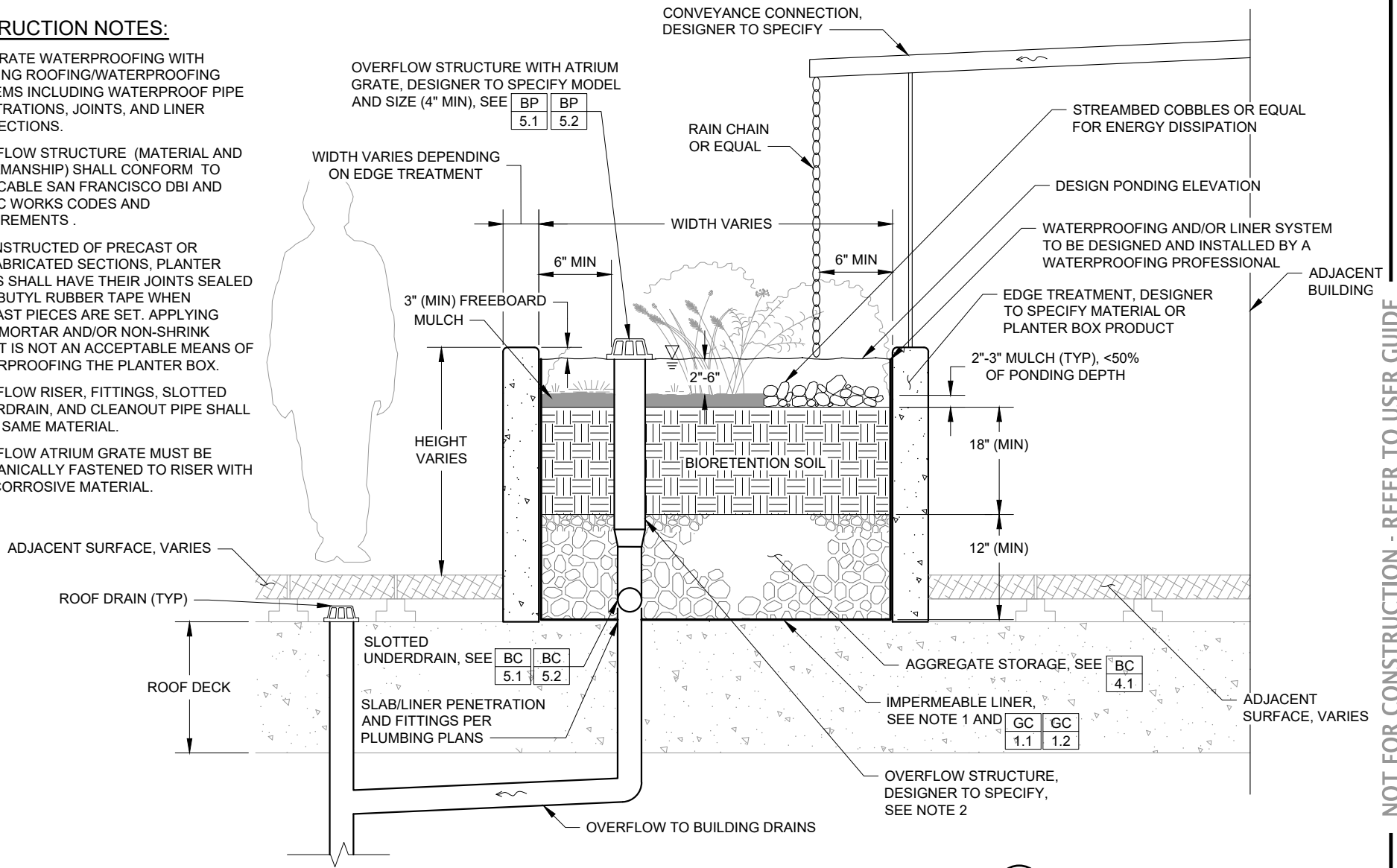

SECTION - BIORETENTION PLANTER ON STRUCTURE C

ROADSIDE APPLICATIONS										PARCEL APPLICATIONS								
NOTES		W/PARKING		W/O PARKING		BULBOUT						NOTES		PLAN		SECTIONS		
BP	BP	BP	BP	BP	BP	BP	BP	BP	BP	BP	BP	BP	BP	BP	BP	BP	BP	BP
1.1	1.2	2.1	2.2	3.1	3.2	4.1	4.2	4.3	4.4	4.5	4.6	5.1	5.2	5.3	5.4	5.5	5.6	5.7



**GREEN INFRASTRUCTURE
TYPICAL DETAILS**
SAN FRANCISCO PUBLIC UTILITIES COMMISSION

DATE	JANUARY 2023
VERSION	3.0
REVISED	

**BIORETENTION PLANTER
PARCEL PLANTER
PLANTER ON STRUCTURE SECTION**

DWG. NO.
**BP
5.7**

NOT FOR CONSTRUCTION - REFER TO USER GUIDE

PURPOSE:

ROADSIDE BIORETENTION BASINS IN:

- CSS AREAS: CONTROL PEAK FLOWS AND VOLUMES OF STORMWATER RUNOFF BY PROVIDING SURFACE, SUBSURFACE STORAGE AND INFILTRATION INTO NATIVE SOIL;
- MS4 AREAS: REMOVE POLLUTANTS OF CONCERN AS WATER FILTERS THROUGH BIORETENTION SOIL.

DESIGNER NOTES & GUIDELINES:

1. THE DESIGNER MUST ADAPT PLAN AND SECTION DRAWINGS TO ADDRESS SITE-SPECIFIC CONDITIONS.
2. FACILITY AREA, PONDING DEPTH, BIORETENTION SOIL DEPTH, AND AGGREGATE STORAGE DEPTH MUST BE SIZED TO MEET PROJECT HYDROLOGIC PERFORMANCE GOALS.
3. PONDING AND BIORETENTION SOIL DRAWDOWN TIME (I.E., TIME FOR MAXIMUM SURFACE PONDING TO DRAIN THROUGH THE BIORETENTION SOIL AFTER THE END OF A STORM) RECOMMENDATIONS:
 - 3 - 12 HOUR DRAWDOWN FOR PONDING AND BIORETENTION SOIL (TYPICAL)
 - 24 HOUR MAXIMUM DRAWDOWN FOR PONDING AND BIORETENTION SOIL
4. FACILITY DRAWDOWN TIME (I.E., TIME FOR SURFACE PONDING TO DRAIN THROUGH THE ENTIRE SECTION INCLUDING AGGREGATE STORAGE AFTER THE END OF A STORM) REQUIREMENTS:
 - 48 HOUR MAXIMUM FACILITY DRAWDOWN (I.E., ORIFICE CONTROLLED SYSTEM OR EXTENDED STORAGE DEPTH WITHIN INFILTRATION SYSTEM).
5. AN AGGREGATE COURSE IS REQUIRED UNDER THE BIORETENTION SOIL FOR BIORETENTION IN SEPARATE SEWER SYSTEM AREAS. USE AGGREGATE COURSE WHERE REQUIRED (E.G., WITH UNDERDRAIN, FOR STORAGE, ETC.) FOR FACILITIES IN COMBINED SEWER SYSTEM AREAS.
6. THE PLANTER WALL SLOPE IS TYPICALLY DESIGNED TO MATCH THE LONGITUDINAL SLOPE OF THE ADJACENT ROADWAY/SIDEWALK. CHECK DAMS MAY BE USED FOR HIGHER-SLOPED INSTALLATIONS TO TERRACE FACILITIES TO PROVIDE SUFFICIENT PONDING AND TO MINIMIZE LARGE ELEVATION DROPS FROM ADJACENT SURFACES. DESIGNER MUST SPECIFY CHECK DAM HEIGHT AND SPACING. REFER TO **BC 6.1** AND **BC 6.2** FOR GUIDANCE ON CHECK DAM DESIGN.
7. THE FOLLOWING GUIDELINES APPLY TO RIGHT-OF-WAY APPLICATIONS:
 - BULBOUT CURB TRANSITIONS SHALL CONFORM TO SFPW STANDARD PLAN 87,175.
 - WHEN FACILITY CONSTRUCTION IMPACTS EXISTING SIDEWALK, ALL SAW CUTS MUST ADHERE TO SFPUC REQUIREMENTS. SAW CUTS SHOULD BE ALONG SCORE LINES AND ANY DISTURBED SIDEWALK FLAGS SHOULD BE REPLACED IN THEIR ENTIRETY.
 - DESIGNER TO SPECIFY TRANSITION OF PLANTER SOIL ELEVATIONS BETWEEN CURB CUTS.
8. IF FACILITY IS SUBJECT TO ACCEPTANCE AS SFPUC ASSET, OVERFLOWS MUST BE DESIGNED TO MEET ROW REQUIREMENTS ON **BP 1.1**.
9. MINIMUM UTILITY SETBACKS AND PROTECTION MEASURES MUST CONFORM TO CURRENT SFPUC ASSET PROTECTION STANDARDS AND OTHER UTILITY PROVIDERS REQUIREMENTS. SEE UTILITY CROSSINGS (**GC 2.1 - GC 2.12**) AND UTILITY CONFLICTS (**GC 4.1 - GC 4.4**).
10. PLANTER VEGETATION MUST BE SPECIFIED BY DESIGN PROFESSIONAL PER SFPUC VEGETATION PALETTE.
11. CONVEYANCE CONNECTIONS MAY BE CONFIGURED TO ACCEPT RUNOFF VIA OVERHEAD CONVEYANCE (DOWNSPOUTS, OVERHEAD RUNNELS), SURFACE FLOW (CHANNELS) OR SUBSURFACE CONVEYANCE (PIPES, TRENCH DRAINS). REFER TO APPLICABLE SAN FRANCISCO DBI CODES FOR CONVEYANCE CONNECTION REQUIREMENTS.
12. CONVEYANCE CONNECTIONS (E.G., SCUPPER CHANNEL, PIPE) SHALL BE SIZED TO ACCOMMODATE DRAINAGE FROM ROOF AREA WITH ADEQUATE FREEBOARD TO AVOID OVERFLOWING. REFER TO APPLICABLE SAN FRANCISCO DBI CODES FOR CONVEYANCE REQUIREMENTS.
13. UNDERDRAIN LENGTHS SHALL BE SIZED FOR SUFFICIENT CAPACITY TO CONVEY THE PEAK FLOW TO THE BMP. THIS LENGTH SHALL BE BASED ON A CAPACITY OF 0.0047 CFS/LF.

DESIGNER CHECKLIST

(MUST SPECIFY, AS APPLICABLE):

- FACILITY WIDTH, LENGTH, SLOPES (INCLUDING SIDE, CROSS, AND LONGITUDINAL), AND SHAPE
- DEPTH OF PONDING
- DEPTH OF FREEBOARD
- DEPTH OF BIORETENTION SOIL
- DEPTH AND TYPE OF AGGREGATE STORAGE, IF ANY
- PLANTER SURFACE ELEVATION (TOP OF BIORETENTION SOIL) AT UPSLOPE AND DOWNSLOPE ENDS OF FACILITY (I.E., PROVIDE SPOTS AND/OR CONTOURS AS NEEDED)
- DEFINED SURVEY POINTS AT EVERY CORNER OF FACILITY AND POINT OF TANGENCY
- HORIZONTAL CONTROL: DIMENSIONS AND DISTANCE TO EVERY INLET, OUTLET, CHECK DAM, SIDEWALK NOTCH, ETC.
- VERTICAL CONTROL: ELEVATIONS OF EVERY INLET, OUTLET, STRUCTURE RIM AND INVERT, CHECK DAM, AND SIDEWALK NOTCH
- TYPE AND DESIGN OF FACILITY COMPONENTS (E.G., EDGE TREATMENTS, INLETS/GUTTER MODIFICATIONS, UTILITY CROSSINGS, LINER, AND PLANTING DETAILS)
- MINIMUM UNDERDRAIN LENGTH TO CONVEY FLOW TO BMP

LAYOUT REQUIREMENTS:

1. FOR RIGHT-OF-WAY APPLICATIONS, REFER TO THE SAN FRANCISCO STANDARD ACCESSIBILITY REQUIREMENTS IN THE SFPW SIDEWALK LANDSCAPING REFERENCE DRAWINGS AND SPECIFICATIONS FOR CONSTRUCTION FOR COURTESY STRIP, THROUGHWAY, PARKING SPACE AND ACCESSIBLE PATH REQUIREMENTS.
2. FOR PUBLIC AND/OR PUBLICLY ACCESSIBLE BIORETENTION BASINS, LANDSCAPE LEVEL BENCH WIDTH MAY VARY PER ACCESSIBILITY REQUIREMENTS.
3. LOCATE CURB CUTS AND GUTTER MODIFICATIONS TO AVOID CONFLICTS WITH ACCESSIBILITY REQUIREMENTS (E.G., OVERFLOWS SHALL DISCHARGE TO CB OR INLET PRIOR TO CROSSING A CURB RAMP OR SIDEWALK).
4. REFER TO SHEET GEN 0.2 AND APPENDIX C OF THE STORMWATER MANAGEMENT REQUIREMENTS FOR MORE DETAILED INFORMATION ON SITING AND DESIGN REQUIREMENTS FOR INFILTRATION-BASED BMPs.

RELATED COMPONENTS

EDGE TREATMENTS:	BC 1.1	BC 1.7
INLETS:	BC 2.1	BC 2.4
OUTLETS:	BC 3.1	BC 3.4
AGGREGATE STORAGE:	BC 4.1	
UNDERDRAINS:	BC 5.1	BC 5.2
CHECK DAMS:	BC 6.1	BC 6.2
LINERS:	GC 1.1	GC 1.2
UTILITY CROSSINGS:	GC 2.1	GC 2.12
OBSERVATION PORTS:	GC 3.1	GC 3.3
UTILITY CONFLICTS:	GC 4.1	GC 4.4
CLEANOUTS:	GC 5.2	

RELATED SPECIFICATIONS	CSI NO.
BIORETENTION: - BIORETENTION SOIL MIX - AGGREGATE STORAGE - MULCH - STREAMBED COBBLES	33 47 27

NOTES	SECTIONS	
BB 1.1	BB 2.1	BB 2.2



**GREEN INFRASTRUCTURE
TYPICAL DETAILS**
SAN FRANCISCO PUBLIC UTILITIES COMMISSION

DATE	JANUARY 2023
VERSION	3.0
REVISED	

**BIORETENTION BASIN
DESIGNER NOTES**

DWG. NO.
**BB
1.1**

NOT FOR CONSTRUCTION - REFER TO USER GUIDE

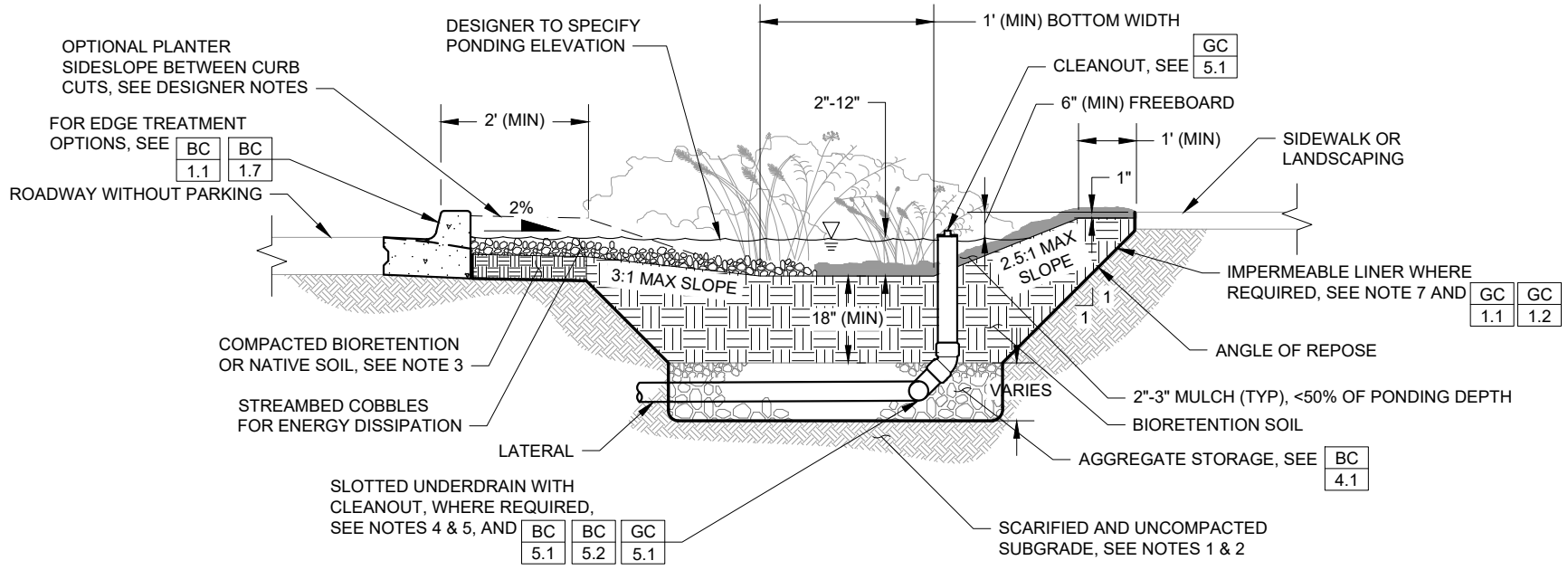

SECTION - BIORETENTION RECEIVING SHEETFLOW 1

CONSTRUCTION NOTES:

1. FOR UNLINED BASINS ONLY, AVOID COMPACTION OF EXISTING SUBGRADE BELOW BASIN.
2. FOR UNLINED BASINS ONLY, SCARIFY SUBGRADE TO A DEPTH OF 3 INCHES (MIN) IMMEDIATELY PRIOR TO PLACEMENT OF AGGREGATE STORAGE AND BIORETENTION SOIL MATERIALS.
3. COMPACT BIORETENTION SOIL IMMEDIATELY BEHIND CURB TO 90% OF MAXIMUM DENSITY PER STANDARD PROCTOR TEST (ASTM D698).
4. UNDERDRAIN REQUIRED FOR ALL FACILITIES WITH IMPERMEABLE LINER.
5. PROVIDE ONE CLEANOUT PER PLANTER (MIN) FOR FACILITIES WITH UNDERDRAINS.
6. MINIMUM UTILITY SETBACKS AND PROTECTION MEASURES MUST CONFORM TO CURRENT SFPUC ASSET PROTECTION STANDARDS. COORDINATE WITH ENGINEER IN THE EVENT OF UTILITY CROSSING AND UTILITY CONFLICTS.
7. PRIOR TO PLACEMENT OF IMPERMEABLE LINER, THE SUBGRADE SHALL BE PREPARED AND CONTOURED AS NECESSARY TO PROVIDE A SMOOTH SURFACE, VOID OF SHARP ROCKS/DEBRIS. NO VOID SPACES SHALL BE PRESENT BETWEEN THE LINER AND THE SUBGRADE. GEOTEXTILE FABRIC MAY BE INSTALLED BETWEEN THE SUBGRADE AND THE LINER TO PROTECT THE LINER FROM SHARP AGGREGATE PRESENT IN THE SUBGRADE. ENGINEER SHALL INSPECT/APPROVE THE PREPARED BASIN SUBGRADE PRIOR TO THE INSTALLATION OF ANY OVERLAYING GEOTEXTILE MATERIAL. SEE BIORETENTION SPECIFICATION.

NOTES	SECTIONS	
BB 1.1	BB 2.1	BB 2.2



**GREEN INFRASTRUCTURE
TYPICAL DETAILS**
SAN FRANCISCO PUBLIC UTILITIES COMMISSION

DATE	JANUARY 2023
VERSION	3.0
REVISED	

**BIORETENTION BASIN
ROADSIDE SECTION**

DWG. NO.
**BB
2.1**

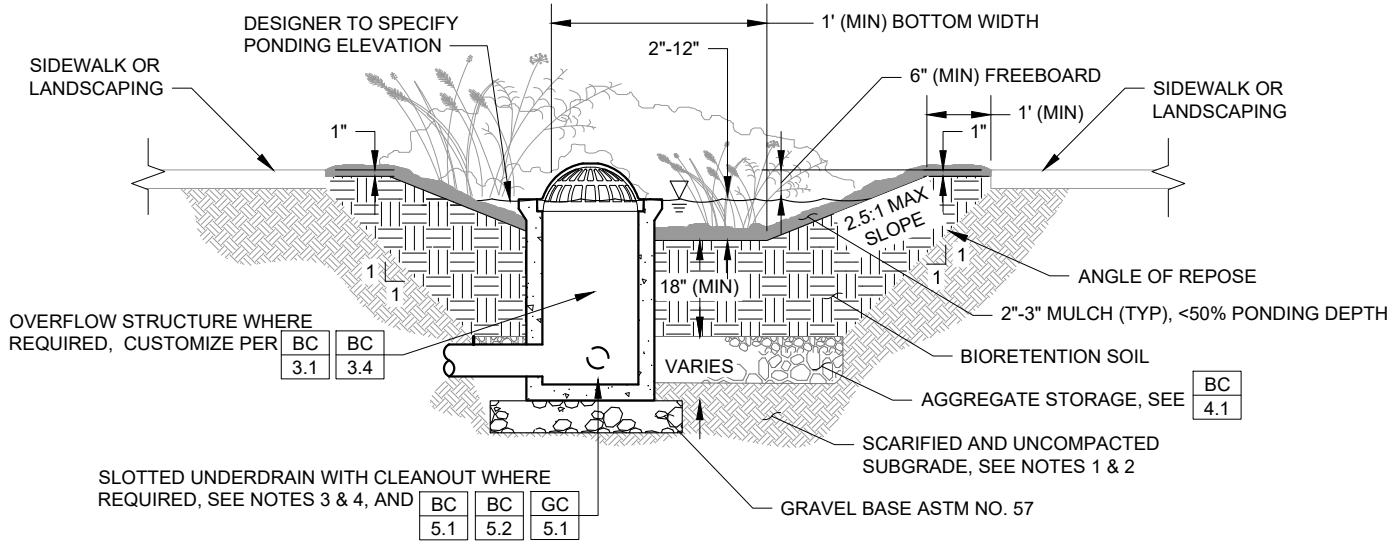

SECTION 1 - BIORETENTION, UNLINED
 CONCEPTUAL DESIGN ONLY - DESIGNER TO CUSTOMIZE 1

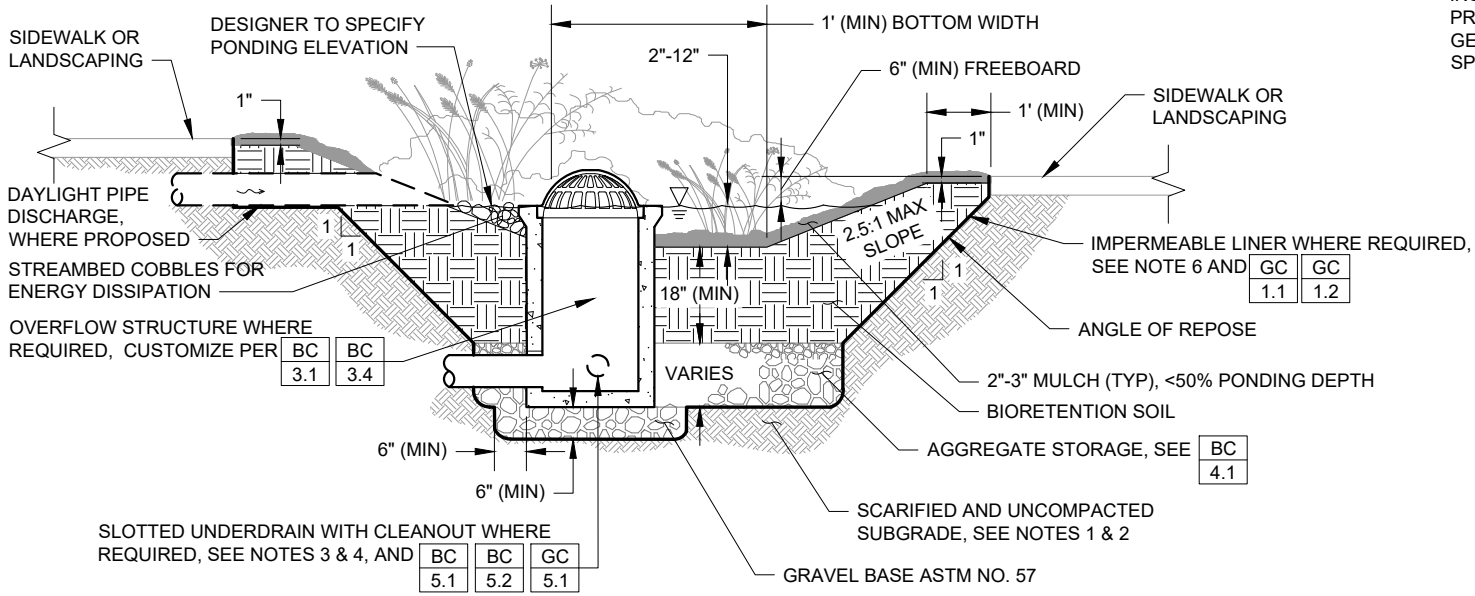

SECTION 2 - BIORETENTION, LINED
 CONCEPTUAL DESIGN ONLY - DESIGNER TO CUSTOMIZE 2

CONSTRUCTION NOTES:

1. FOR UNLINED BASINS ONLY, AVOID COMPACTION OF EXISTING SUBGRADE BELOW BASIN.
2. FOR UNLINED BASINS ONLY, SCARIFY SUBGRADE TO A DEPTH OF 3 INCHES (MIN) IMMEDIATELY PRIOR TO PLACEMENT OF AGGREGATE STORAGE AND BIORETENTION SOIL MATERIALS.
3. UNDERDRAIN REQUIRED FOR ALL FACILITIES WITH IMPERMEABLE LINER.
4. PROVIDE ONE CLEANOUT PER PLANTER (MIN) FOR FACILITIES WITH UNDERDRAINS.
5. MINIMUM UTILITY SETBACKS AND PROTECTION MEASURES MUST CONFORM TO CURRENT SFPUC ASSET PROTECTION STANDARDS. COORDINATE WITH ENGINEER IN THE EVENT OF UTILITY CROSSING AND UTILITY CONFLICTS.
6. PRIOR TO PLACEMENT OF IMPERMEABLE LINER, THE SUBGRADE SHALL BE PREPARED AND CONTOURED AS NECESSARY TO PROVIDE A SMOOTH SURFACE, VOID OF SHARP ROCKS/DEBRIS. NO VOID SPACES SHALL BE PRESENT BETWEEN THE LINER AND THE SUBGRADE. GEOTEXTILE FABRIC MAY BE INSTALLED BETWEEN THE SUBGRADE AND THE LINER TO PROTECT THE LINER FROM SHARP AGGREGATE PRESENT IN THE SUBGRADE. ENGINEER SHALL INSPECT/APPROVE THE PREPARED BASIN SUBGRADE PRIOR TO THE INSTALLATION OF ANY OVERLAYING GEOTEXTILE MATERIAL. SEE BIORETENTION SPECIFICATION.

NOT FOR CONSTRUCTION - REFER TO USER GUIDE

NOTES	SECTIONS	
1.1	BB 2.1	BB 2.2



**GREEN INFRASTRUCTURE
 TYPICAL DETAILS**

SAN FRANCISCO PUBLIC UTILITIES COMMISSION

DATE	JANUARY 2023
VERSION	3.0
REVISED	

**BIORETENTION BASIN
 PARCEL SECTION**

DWG NO.
**BB
 2.2**

PURPOSE:

EDGE TREATMENTS ARE USED TO DEFINE THE BOUNDARIES OF A BIORETENTION FACILITY AND ARE INTENDED PRIMARILY TO STABILIZE THE EDGE OF ADJACENT PAVEMENT AND MINIMIZE LATERAL MOVEMENT OF WATER, AS APPLICABLE. IN CASES WHERE ADEQUATE SPACE IS AVAILABLE, THE FACILITY SIDESLOPE CAN BE LAID BACK SUCH THAT THE SURROUNDING NATIVE SOIL IS STABLE AND CAN FUNCTION AS THE FACILITY EDGE TREATMENT. HOWEVER, WHEN SPACE IS LIMITED, EDGE TREATMENTS SUCH AS VERTICAL WALLS MAY BE USED TO MAINTAIN THE STRUCTURAL INTEGRITY OF THE SURROUNDING SURFACES. THESE EDGE TREATMENTS RETAIN STORMWATER WITHIN THE FACILITY (AND OUT OF THE SURROUNDING PAVEMENT SECTIONS, AS APPLICABLE) UNTIL WATER INFILTRATES, IS COLLECTED BY THE UNDERDRAIN, OR OVERFLOWS VIA THE DESIGNATED OUTLETS.

DESIGNER NOTES & GUIDELINES:

1. THE DESIGNER MUST ADAPT DRAWINGS TO ADDRESS SITE-SPECIFIC CONDITIONS.
2. MINIMUM EDGE TREATMENT EMBEDMENT DEPTHS ARE SPECIFIED TO PREVENT LATERAL SEEPAGE UNDER THE EDGE TREATMENT AND INTO ADJACENT PAVEMENT SECTIONS, AS APPLICABLE.
3. DESIGNER MAY ELIMINATE CONSTRUCTION BENCH TO INCREASE EFFECTIVE FACILITY AREA (I.E. INFILTRATION AND STORAGE FOOTPRINT) PROVIDED PLANTER WALL EXTENDS TO BOTTOM OF AGGREGATE STORAGE.
4. DESIGNER MAY SPECIFY ALTERNATIVE MATERIAL TYPE FOR EDGE TREATMENTS PROVIDED MATERIAL MEETS STRUCTURAL REQUIREMENTS FOR LOADING CONDITIONS, SERVES AS A WATER BARRIER BETWEEN THE FACILITY AND ADJACENT PAVEMENT SECTIONS (AS APPLICABLE), AND COMPLIES WITH SFPW STANDARD ACCESSIBILITY REQUIREMENTS.
5. ALL WALLS (I.E., SHORT AND EXTENDED) SHALL BE STRUCTURALLY DESIGNED FOR LATERAL LOADING. COORDINATE WITH STRUCTURAL ENGINEER AS NEEDED.
6. FOOTING OR LATERAL BRACING SHALL BE PROVIDED FOR ALL PLANTER WALLS UNLESS THE DESIGNER DEMONSTRATES THAT THE PROPOSED WALL DESIGN MEETS LOADING REQUIREMENTS.
7. PLANTER WALLS THAT RETAIN SOIL SHALL BE DESIGNED TO RESIST SLIDING AND OVERTURNING.
8. FOOTINGS AND LATERAL BRACING SHALL BE DESIGNED TO WITHSTAND ANTICIPATED LOADING ASSUMING NO REACTIVE FORCES FROM THE UNCOMPACTED BIORETENTION SOIL WITHIN THE FACILITY.
9. LATERAL BRACING SHALL MEET HYDROLOGIC AND HYDRAULIC DESIGN REQUIREMENTS FOR CHECK DAMS WHEN USED AS CHECK DAMS. SEE **BC 6.1**.
10. PLANTER WALLS EXTENDING MORE THAN 36 INCHES BELOW ADJACENT LOAD-BEARING SURFACE, OR WHEN LOCATED ADJACENT TO PAVERS, MUST HAVE FOOTING OR LATERAL BRACING. SEE **BC 1.5**.
11. UNDERDRAIN LENGTHS SHALL BE SIZED FOR SUFFICIENT CAPACITY TO CONVEY THE PEAK FLOW TO THE BMP. THIS LENGTH SHALL BE BASED ON A CAPACITY OF 0.0047 CFS/LF.

DESIGNER CHECKLIST (MUST SPECIFY, AS APPLICABLE):

- EDGE TREATMENT TYPE AND MATERIAL
- EDGE TREATMENT WIDTH AND HEIGHT
- EMBEDMENT DEPTH INTO SUBGRADE SOILS
- LATERAL BRACING/FOOTING REQUIREMENTS
- PIPE MATERIAL AND DIAMETER FOR ALL WALL PENETRATIONS
- WATER TIGHT CONNECTOR TYPE FOR ALL WALL PENETRATIONS (E.G., GROUTED, COMPRESSION, BOOT) SEE **GC 2.9** AND **GC 2.10**.
- ELEVATIONS - INLET, OUTLET, OVERFLOW STRUCTURE (RIM & INVERT), CLEANOUT (RIM & INVERT)
- ELEVATIONS - TOP OF SLOPE AND TOE OF SLOPE
- MINIMUM UNDERDRAIN LENGTH TO CONVEY PEAK FLOW TO BMP

NOT FOR CONSTRUCTION - REFER TO USER GUIDE

EDGE TREATMENTS							INLETS			OUTLETS			AGGREGATE STORAGE COMPONENTS	UNDERDRAINS			CHECK DAM		MONITORING				
NOTES	COMPONENTS						NOTES	COMPONENTS			NOTES	COMPONENTS			BC	NOTES	COMPONENTS	NOTES	COMPONENTS				
BC 1.1	BC 1.2	BC 1.3	BC 1.4	BC 1.5	BC 1.6	BC 1.7	BC 2.1	BC 2.2	BC 2.3	BC 2.4	BC 3.1	BC 3.2	BC 3.3	BC 3.4	BC 4.1	BC 5.1	BC 5.2	BC 5.3	BC 6.1	BC 6.2	BC 7.1	BC 7.2	BC 7.3



San Francisco
**Water
Power
Sewer**

**GREEN INFRASTRUCTURE
TYPICAL DETAILS**

SAN FRANCISCO PUBLIC UTILITIES COMMISSION

DATE	JANUARY 2023
VERSION	3.0
REVISED	

**BIORETENTION COMPONENTS
EDGE TREATMENTS
DESIGNER NOTES**

DWG NO.
**BC
1.1**

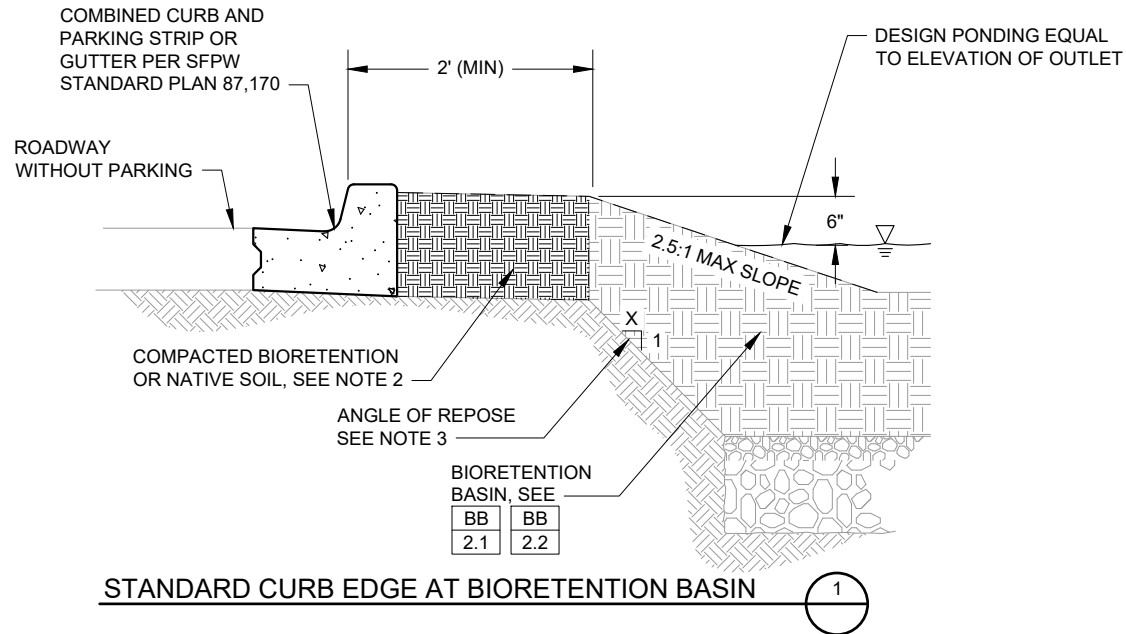

CONSTRUCTION NOTES:

1. ALL MATERIAL AND WORKMANSHIP FOR EDGE TREATMENTS SHALL CONFORM TO STANDARD SPECIFICATIONS AND APPLICABLE CODES PER SAN FRANCISCO DBI AND PUBLIC WORKS.
2. COMPACT BIORETENTION OR NATIVE SOIL TO 90% OF MAXIMUM DENSITY PER STANDARD PROCTOR TEST (ASTM D698).
3. ANGLE OF REPOSE VARIES PER GEOTECHNICAL ENGINEERS RECOMMENDATIONS.

EDGE TREATMENTS							INLETS				OUTLETS				AGGREGATE STORAGE COMPONENTS	UNDERDRAINS			CHECK DAM		MONITORING		
NOTES	COMPONENTS						NOTES	COMPONENTS			NOTES	COMPONENTS			BC	NOTES	COMPONENTS		NOTES	COMPONENTS			
1.1	BC 1.2	BC 1.3	BC 1.4	BC 1.5	BC 1.6	BC 1.7	BC 2.1	BC 2.2	BC 2.3	BC 2.4	BC 3.1	BC 3.2	BC 3.3	BC 3.4	BC 4.1	BC 5.1	BC 5.2	BC 5.3	BC 6.1	BC 6.2	BC 7.1	BC 7.2	BC 7.3



**GREEN INFRASTRUCTURE
TYPICAL DETAILS**
SAN FRANCISCO PUBLIC UTILITIES COMMISSION

DATE
JANUARY 2023
VERSION
3.0
REVISED

**BIORETENTION COMPONENTS
EDGE TREATMENTS
VEHICULAR APPLICATIONS (1 OF 2)**

DWG NO.
**BC
1.2**

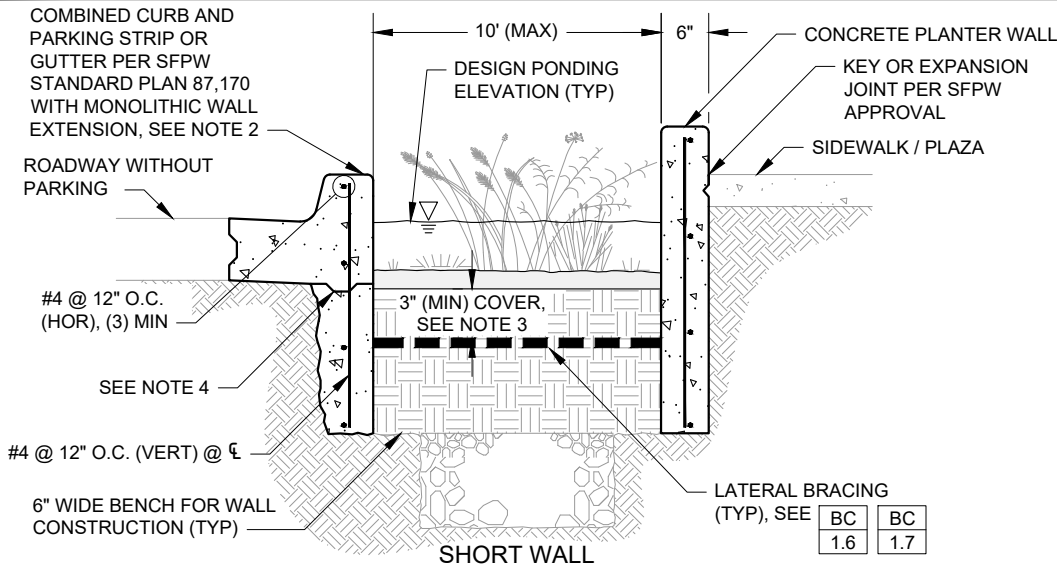

SHORT WALL

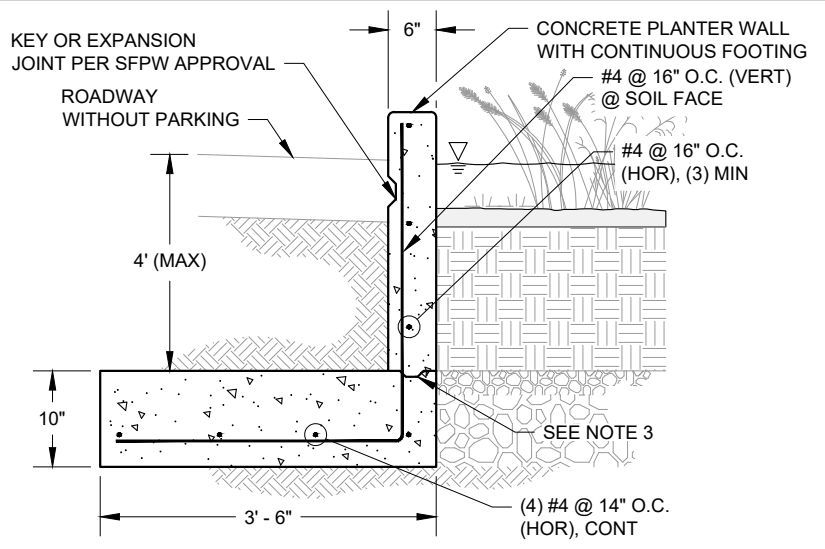

PLANTER WALL WITH CONTINUOUS FOOTING 2

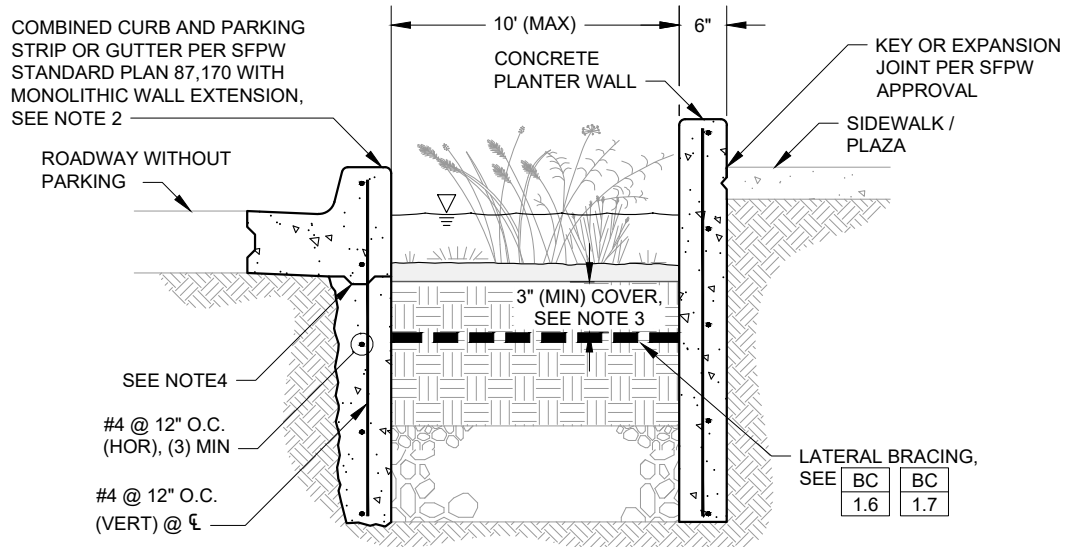

EXTENDED WALL
PLANTER WALL WITH LATERAL BRACING 1

CONSTRUCTION NOTES:

1. ALL MATERIAL AND WORKMANSHIP FOR EDGE TREATMENTS SHALL CONFORM TO SAN FRANCISCO STANDARD SPECIFICATIONS AND APPLICABLE CODES PER SAN FRANCISCO DBI AND PUBLIC WORKS.
2. ALL PLANTER WALLS SHALL EXTEND TO BOTTOM OF BIORETENTION SOIL OR DEEPER.
3. CONTRACTOR TO PROVIDE 3 INCH MINIMUM COVER OVER ALL LATERAL BRACING FOR PLANT ESTABLISHMENT.
4. ALL CONSTRUCTION COLD JOINTS SHALL INCORPORATE EPOXY, DOWEL/TIE BAR, KEYWAY, OR WATER STOP.

EDGE TREATMENTS							INLETS				OUTLETS				AGGREGATE STORAGE COMPONENTS	UNDERDRAINS			CHECK DAM		MONITORING		
NOTES	COMPONENTS						NOTES	COMPONENTS			NOTES	COMPONENTS			BC	NOTES	COMPONENTS		NOTES	COMPONENTS			
BC 1.1	BC 1.2	BC 1.3	BC 1.4	BC 1.5	BC 1.6	BC 1.7	BC 2.1	BC 2.2	BC 2.3	BC 2.4	BC 3.1	BC 3.2	BC 3.3	BC 3.4	BC 4.1	BC 5.1	BC 5.2	BC 5.3	BC 6.1	BC 6.2	BC 7.1	BC 7.2	BC 7.3



**GREEN INFRASTRUCTURE
TYPICAL DETAILS**
SAN FRANCISCO PUBLIC UTILITIES COMMISSION

DATE	JANUARY 2023
VERSION	3.0
REVISED	

BIORETENTION COMPONENTS
EDGE TREATMENTS
VEHICULAR APPLICATIONS (2 OF 2)

DWG NO.
BC 1.3

NOT FOR CONSTRUCTION - REFER TO USER GUIDE

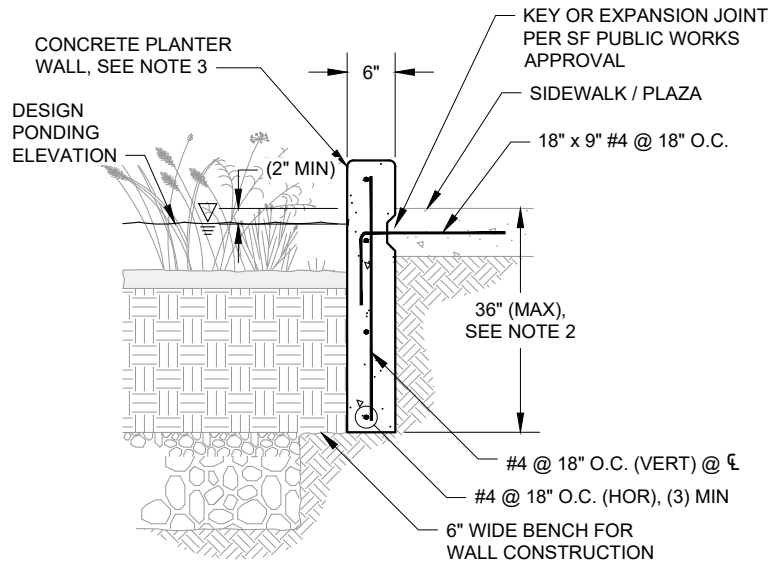

PLANTER WALL - PARCEL ONLY

1

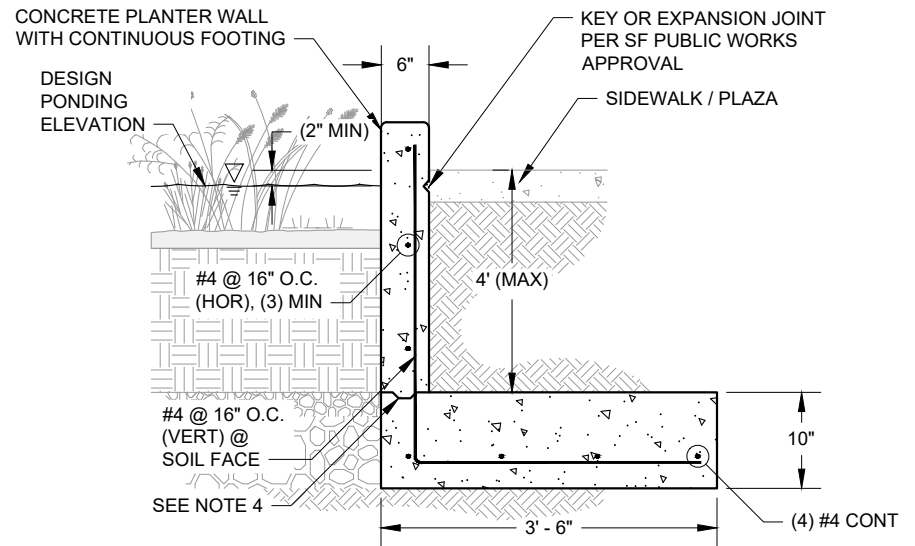

PLANTER WALL WITH CONTINUOUS FOOTING

2

CONSTRUCTION NOTES:

1. ALL MATERIAL AND WORKMANSHIP FOR EDGE TREATMENTS SHALL CONFORM TO STANDARD SPECIFICATIONS AND APPLICABLE CODES PER SAN FRANCISCO DBI AND PUBLIC WORKS.
2. PLANTER WALLS EXTENDING MORE THAN 36 INCHES BELOW ADJACENT LOAD-BEARING SURFACE, OR WHEN LOCATED ADJACENT TO PAVERS, MUST HAVE FOOTING OR LATERAL BRACING. COORDINATE WITH ENGINEER.
3. ALL PLANTER WALLS SHALL EXTEND TO BOTTOM OF BIORETENTION SOIL OR DEEPER.
4. ALL CONSTRUCTION COLD JOINTS SHALL INCORPORATE EPOXY, DOWEL/TIE BAR, KEYWAY, OR WATER STOP.

EDGE TREATMENTS							INLETS				OUTLETS				AGGREGATE STORAGE COMPONENTS	UNDERDRAINS			CHECK DAM		MONITORING		
NOTES	COMPONENTS						NOTES	COMPONENTS			NOTES	COMPONENTS			BC	NOTES	COMPONENTS		NOTES	COMPONENTS			
BC 1.1	BC 1.2	BC 1.3	BC 1.4	BC 1.5	BC 1.6	BC 1.7	BC 2.1	BC 2.2	BC 2.3	BC 2.4	BC 3.1	BC 3.2	BC 3.3	BC 3.4	BC 4.1	BC 5.1	BC 5.2	BC 5.3	BC 6.1	BC 6.2	BC 7.1	BC 7.2	BC 7.3



**GREEN INFRASTRUCTURE
TYPICAL DETAILS**
SAN FRANCISCO PUBLIC UTILITIES COMMISSION

DATE	JANUARY 2023
VERSION	3.0
REVISED	

**BIORETENTION COMPONENTS
EDGE TREATMENTS
PEDESTRIAN APPLICATIONS (1 OF 2)**

DWG NO.
**BC
1.4**

NOT FOR CONSTRUCTION - REFER TO USER GUIDE

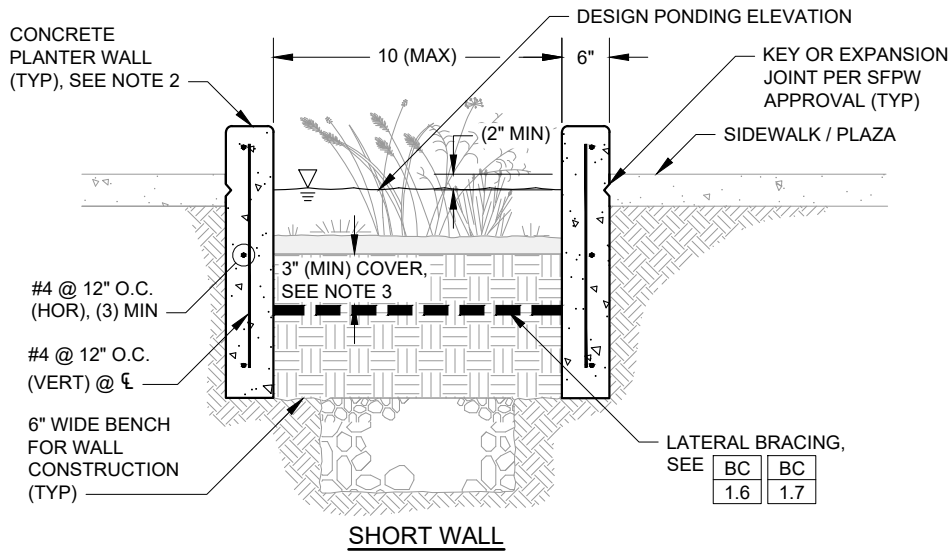

SHORT WALL

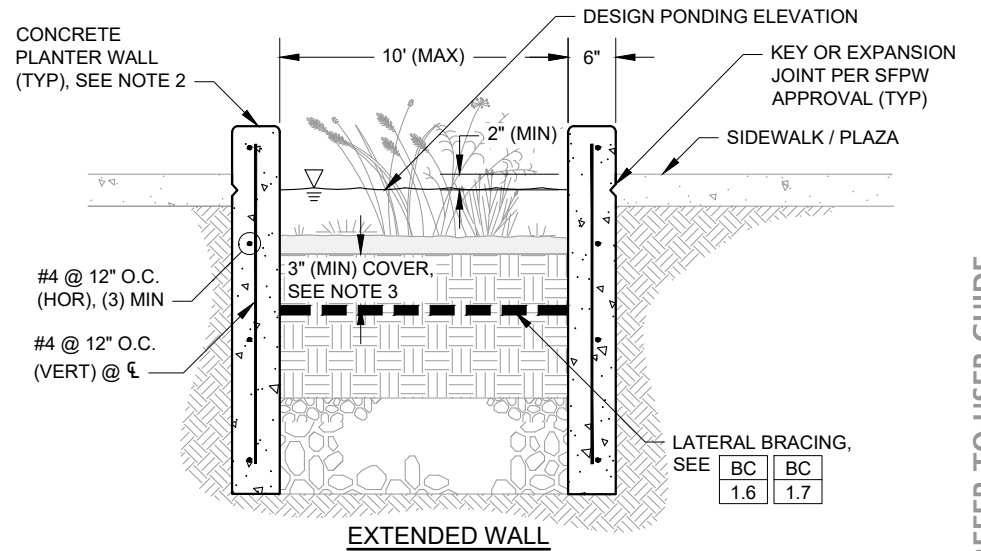

EXTENDED WALL

PLANTER WALL WITH LATERAL BRACING - SHORT ①

PLANTER WALL WITH LATERAL BRACING - EXTENDED ②

CONSTRUCTION NOTES:

1. ALL MATERIAL AND WORKMANSHIP FOR EDGE TREATMENTS SHALL CONFORM TO STANDARD SPECIFICATIONS AND APPLICABLE CODES PER SAN FRANCISCO DBI AND PUBLIC WORKS.
2. ALL PLANTER WALLS SHALL EXTEND TO BOTTOM OF BIORETENTION SOIL OR DEEPER.
3. CONTRACTOR TO PROVIDE 3 INCH MINIMUM COVER OVER ALL LATERAL BRACING FOR PLANT ESTABLISHMENT.
4. ALL CONSTRUCTION COLD JOINTS SHALL INCORPORATE EPOXY, DOWEL/TIE BAR, KEYWAY, AND WATER STOP.

EDGE TREATMENTS							INLETS				OUTLETS				AGGREGATE STORAGE COMPONENTS	UNDERDRAINS			CHECK DAM		MONITORING		
NOTES	COMPONENTS						NOTES	COMPONENTS			NOTES	COMPONENTS			BC	NOTES	COMPONENTS		NOTES	COMPONENTS			
BC 1.1	BC 1.2	BC 1.3	BC 1.4	BC 1.5	BC 1.6	BC 1.7	BC 2.1	BC 2.2	BC 2.3	BC 2.4	BC 3.1	BC 3.2	BC 3.3	BC 3.4	BC 4.1	BC 5.1	BC 5.2	BC 5.3	BC 6.1	BC 6.2	BC 7.1	BC 7.2	BC 7.3



**GREEN INFRASTRUCTURE
TYPICAL DETAILS**
SAN FRANCISCO PUBLIC UTILITIES COMMISSION

DATE	JANUARY 2023
VERSION	3.0
REVISED	

**BIORETENTION COMPONENTS
EDGE TREATMENTS
PEDESTRIAN APPLICATIONS (2 OF 2)**

DWG NO.
**BC
1.5**

NOT FOR CONSTRUCTION - REFER TO USER GUIDE

PLANTER WALL REINFORCING (TYP), SEE

BC	BC
1.2	1.5

PLANTER WALL REINFORCING (TYP), SEE

BC	BC
1.2	1.5

DESIGN PONDING ELEVATION

(1) #4 (TOP), W/ 90° HOOKS @ ENDS
LOCATE LATERAL BRACING AT BOTTOM OF WALL

(1) #5 (BOT), W/ 90° HOOKS @ ENDS

CONCRETE LATERAL BRACING OR EQUAL, SEE NOTES 2 & 3
6" WIDE BENCH FOR WALL CONSTRUCTION
SLOTTED UNDERDRAIN WHERE REQUIRED, SEE

BC	BC
5.1	5.2

SHORT WALL

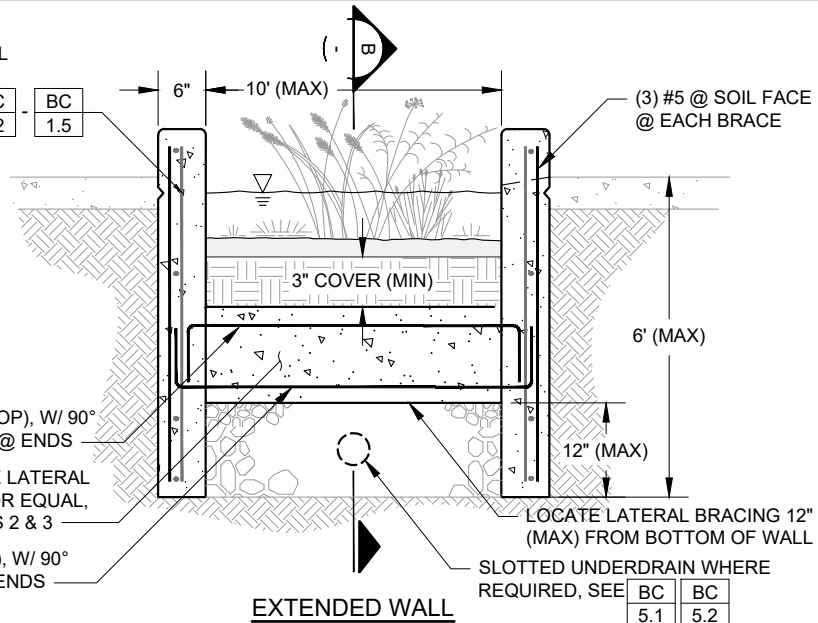

(2) #4 (TOP), W/ 90° HOOKS @ ENDS
CONCRETE LATERAL BRACING OR EQUAL, SEE NOTES 2 & 3
(2) #5 (BOT), W/ 90° HOOKS @ ENDS

(3) #5 @ SOIL FACE @ EACH BRACE
LOCATE LATERAL BRACING 12" (MAX) FROM BOTTOM OF WALL
SLOTTED UNDERDRAIN WHERE REQUIRED, SEE

BC	BC
5.1	5.2

EXTENDED WALL

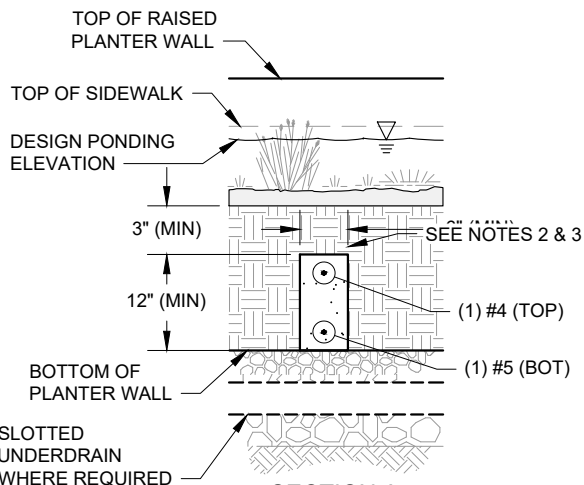

SECTION A
CONCRETE BRACING WALL - SHORT ①

CONSTRUCTION NOTES:

1. ALL MATERIAL AND WORKMANSHIP FOR LATERAL BRACING SHALL CONFORM TO SAN FRANCISCO STANDARD SPECIFICATIONS AND APPLICABLE CODES PER SAN FRANCISCO DBI AND PUBLIC WORKS.
2. CONCRETE LATERAL BRACING SHALL BE CONTINUOUS (NO JOINTS).
3. LATERAL BRACING SHALL BE PROVIDED EVERY 6 FEET (MAX) FOR WALLS UP TO 4 FEET IN HEIGHT AND EVERY 4 FEET (MAX) FOR WALLS BETWEEN 4 AND 6 FEET IN HEIGHT.

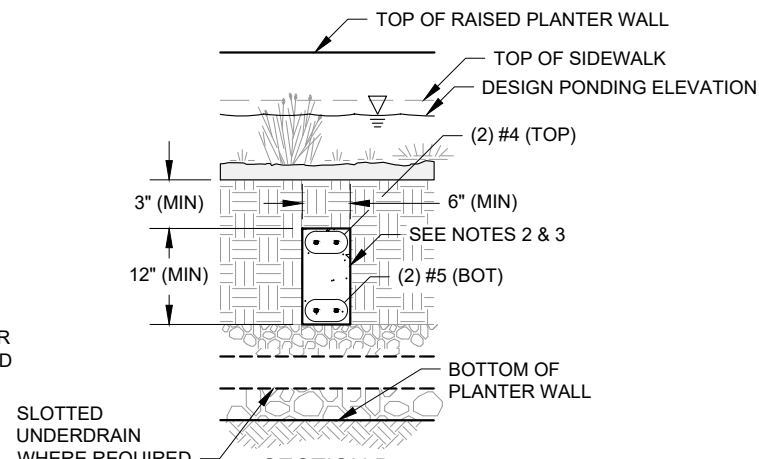

SECTION B
CONCRETE BRACING WALL - EXTENDED ②

EDGE TREATMENTS							INLETS				OUTLETS				AGGREGATE STORAGE COMPONENTS	UNDERDRAINS			CHECK DAM		MONITORING		
NOTES	COMPONENTS						NOTES	COMPONENTS			NOTES	COMPONENTS			BC	NOTES	COMPONENTS		NOTES	COMPONENTS			
BC 1.1	BC 1.2	BC 1.3	BC 1.4	BC 1.5	BC 1.6	BC 1.7	BC 2.1	BC 2.2	BC 2.3	BC 2.4	BC 3.1	BC 3.2	BC 3.3	BC 3.4	BC 4.1	BC 5.1	BC 5.2	BC 5.3	BC 6.1	BC 6.2	BC 7.1	BC 7.2	BC 7.3



GREEN INFRASTRUCTURE
TYPICAL DETAILS
SAN FRANCISCO PUBLIC UTILITIES COMMISSION

DATE
JANUARY 2023
VERSION
3.0
REVISED

BIORETENTION COMPONENTS
EDGE TREATMENTS
LATERAL BRACING (1 OF 2)

DWG NO.
BC
1.6

NOT FOR CONSTRUCTION - REFER TO USER GUIDE

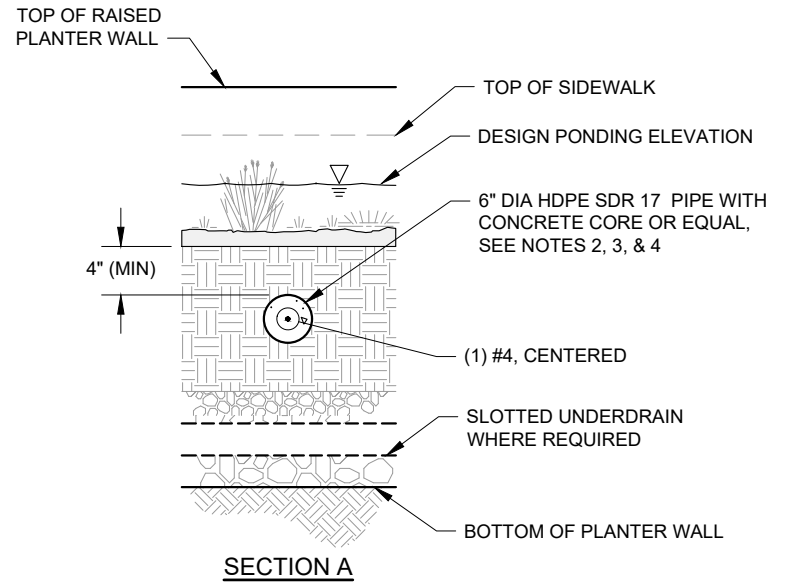
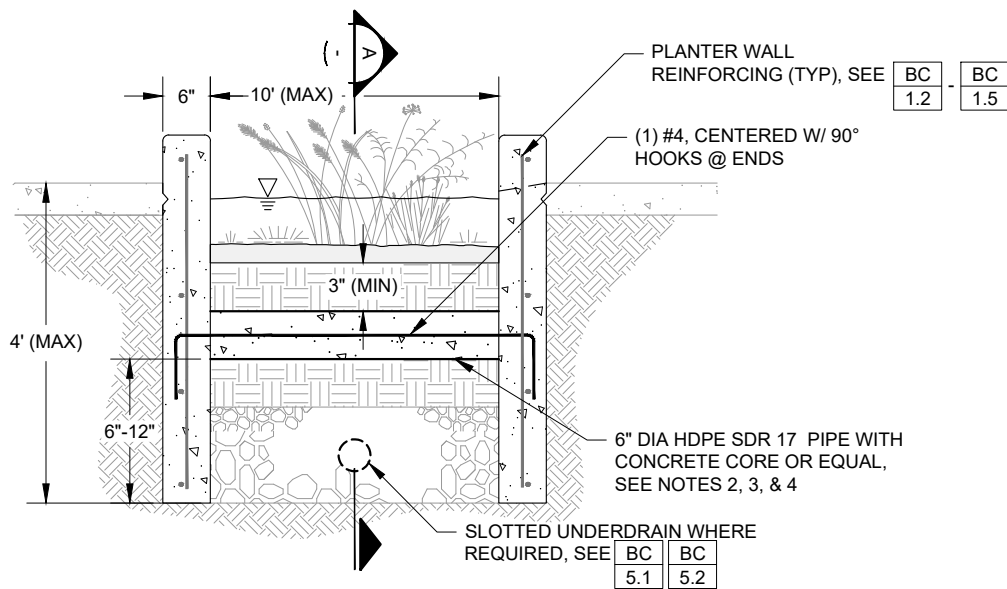

CONCRETE STRUT



CONSTRUCTION NOTES:

1. ALL MATERIAL AND WORKMANSHIP FOR LATERAL BRACING STRUCTURES SHALL CONFORM TO STANDARD SPECIFICATIONS AND APPLICABLE CODES PER SAN FRANCISCO DBI AND PUBLIC WORKS.
2. LATERAL BRACING SHALL BE PROVIDED EVERY 6 FEET (MAX) FOR WALLS UP TO 4 FEET IN HEIGHT.
3. OTHER MATERIALS MAY BE USED IN LIEU OF HDPE PROVIDED MATERIAL IS NON CORROSIVE, NON-LEACHING, AND SCHEDULE 40.
4. PROVIDE 3 INCH CONTINUOUS SLOT ACROSS TOP OF PIPE TO PLACE REINFORCEMENT AND ENSURE STRUT IS FREE OF VOIDS.

EDGE TREATMENTS							INLETS				OUTLETS				AGGREGATE STORAGE COMPONENTS	UNDERDRAINS			CHECK DAM		MONITORING		
NOTES	COMPONENTS						NOTES	COMPONENTS			NOTES	COMPONENTS			BC	NOTES	COMPONENTS		NOTES	COMPONENTS			
BC 1.1	BC 1.2	BC 1.3	BC 1.4	BC 1.5	BC 1.6	BC 1.7	BC 2.1	BC 2.2	BC 2.3	BC 2.4	BC 3.1	BC 3.2	BC 3.3	BC 3.4	BC 4.1	BC 5.1	BC 5.2	BC 5.3	BC 6.1	BC 6.2	BC 7.1	BC 7.2	BC 7.3



**GREEN INFRASTRUCTURE
TYPICAL DETAILS**
SAN FRANCISCO PUBLIC UTILITIES COMMISSION

DATE	JANUARY 2023
VERSION	3.0
REVISED	

BIORETENTION COMPONENTS
EDGE TREATMENTS
LATERAL BRACING (2 OF 2)

DWG NO.
BC 1.7

PURPOSE:

CURB CUTS AND TRENCH DRAINS SERVE AS INLETS TO CONVEY STORMWATER RUNOFF TO A BIORETENTION FACILITY. CURB CUTS ARE TYPICALLY USED IN PLANTER APPLICATIONS WHEN THE FACILITY IS IMMEDIATELY ADJACENT TO THE ROADWAY (I.E. NO COURTESY STRIP), PROVIDING AN OPENING TO INTERCEPT AND CONVEY STORMWATER FROM THE GUTTER TO THE PLANTER. TRENCH DRAIN SYSTEMS ARE MOST COMMONLY USED TO CONVEY STORMWATER FROM A GUTTER THROUGH THE COURTESY STRIP TO A BIORETENTION PLANTER; PROVIDING A CONTINUOUS SURFACE FOR PEDESTRIAN ACCESS WHILE MINIMIZING ELEVATION LOSSES AT THE FACILITY INFLOW LOCATIONS. CURB CUT AND TRENCH DRAIN INLETS INCLUDE MODIFICATIONS TO THE GUTTER TO HELP DIRECT FLOW INTO THE FACILITY.

DESIGNER NOTES & GUIDELINES:

1. THE DESIGNER MUST ADAPT DRAWINGS TO ADDRESS SITE-SPECIFIC CONDITIONS.
2. THE DESIGNER MUST ENSURE THAT CURB CUTS AND TRENCH DRAIN INLETS ARE ADEQUATELY SIZED, SPACED, AND SLOPED TO SATISFY SFPW HYDRAULIC REQUIREMENTS. THE CURB CUT OPENING WIDTH MUST BE SIZED BASED ON THE CATCHMENT AREA, LONGITUDINAL SLOPE ALONG THE CURB, AND THE CROSS SLOPE OF THE GUTTER OR ADJACENT PAVEMENT AT THE INLET. SEE SIZING EQUATIONS AND NOMOGRAPHS FOR CURB OPENING INLETS IN THE U.S. DEPARTMENT OF TRANSPORTATION HYDRAULIC ENGINEERING CIRCULAR NO. 27.
3. TRENCH DRAIN GRATES AND ASSEMBLIES MUST COMPLY WITH SFPW STANDARD.

DESIGNER CHECKLIST (MUST SPECIFY, AS APPLICABLE):

- CURB CUT DIMENSIONS
- FRAME AND GRATE TYPE/MATERIAL AND DIMENSIONS
- CHANNEL DIMENSIONS
- CONTROL ELEVATIONS FOR OPENINGS AT GUTTER AND PLANTER WALL

NOT FOR CONSTRUCTION - REFER TO USER GUIDE

EDGE TREATMENTS							INLETS			OUTLETS			AGGREGATE STORAGE COMPONENTS	UNDERDRAINS			CHECK DAM		MONITORING				
NOTES	COMPONENTS						NOTES	COMPONENTS			NOTES	COMPONENTS			BC	NOTES	COMPONENTS	NOTES	COMPONENTS				
BC 1.1	BC 1.2	BC 1.3	BC 1.4	BC 1.5	BC 1.6	BC 1.7	BC 2.1	BC 2.2	BC 2.3	BC 2.4	BC 3.1	BC 3.2	BC 3.3	BC 3.4	BC 4.1	BC 5.1	BC 5.2	BC 5.3	BC 6.1	BC 6.2	BC 7.1	BC 7.2	BC 7.3



**GREEN INFRASTRUCTURE
TYPICAL DETAILS**
SAN FRANCISCO PUBLIC UTILITIES COMMISSION

DATE	JANUARY 2023
VERSION	3.0
REVISED	

**BIORETENTION COMPONENTS
INLETS
DESIGNER NOTES**

DWG NO.
**BC
2.1**

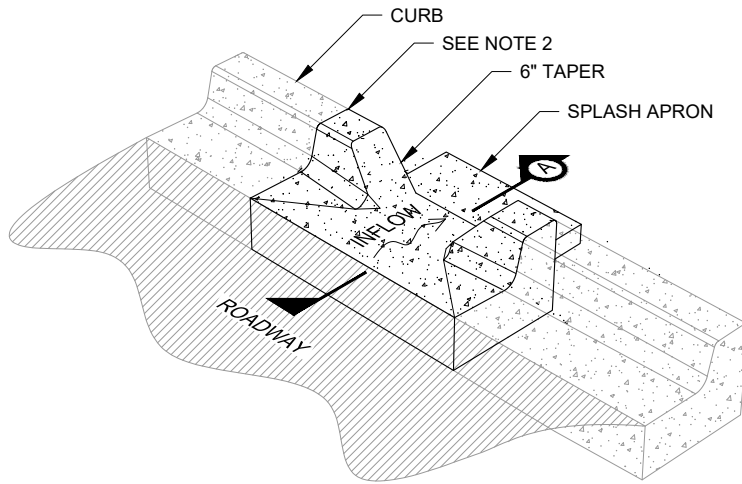

ISOMETRIC

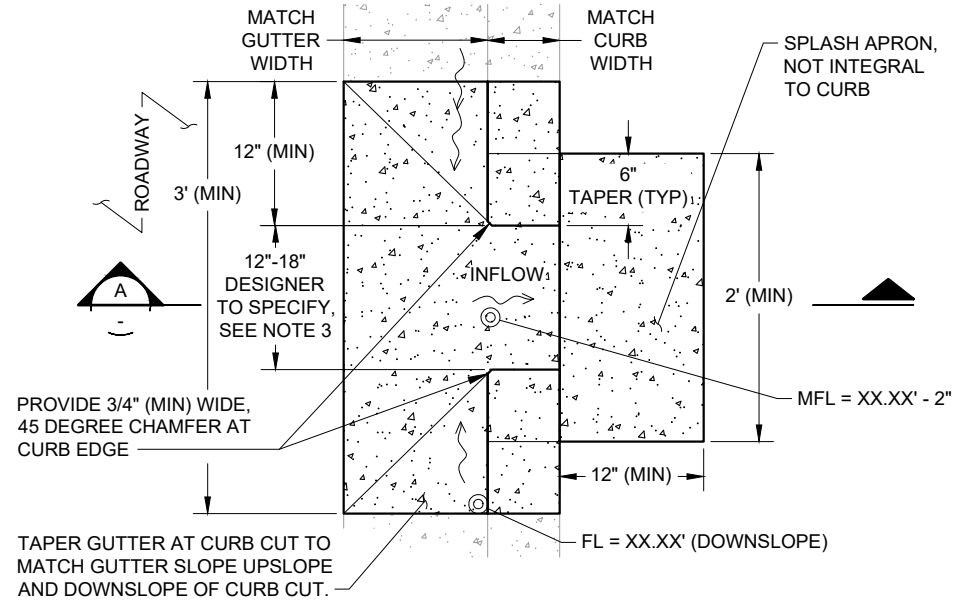

PLAN

CONSTRUCTION NOTES:

1. ALL MATERIAL AND WORKMANSHIP FOR CURB CUTS SHALL CONFORM TO SAN FRANCISCO STANDARD SPECIFICATIONS AND APPLICABLE CODES PER SAN FRANCISCO DBI AND PUBLIC WORKS.
2. BOND NEW CURB AND GUTTER TO EXISTING CURB AND GUTTER WITH EPOXY AND DOWEL CONNECTION.
3. INLET CURB CUT WIDTH SHALL BE 18" ON GUTTER SLOPES \geq 5%
4. MODIFIED FLOW LINE (MFL) TO BE 2" BELOW DOWNSLOPE UNMODIFIED FLOWLINE (FL).

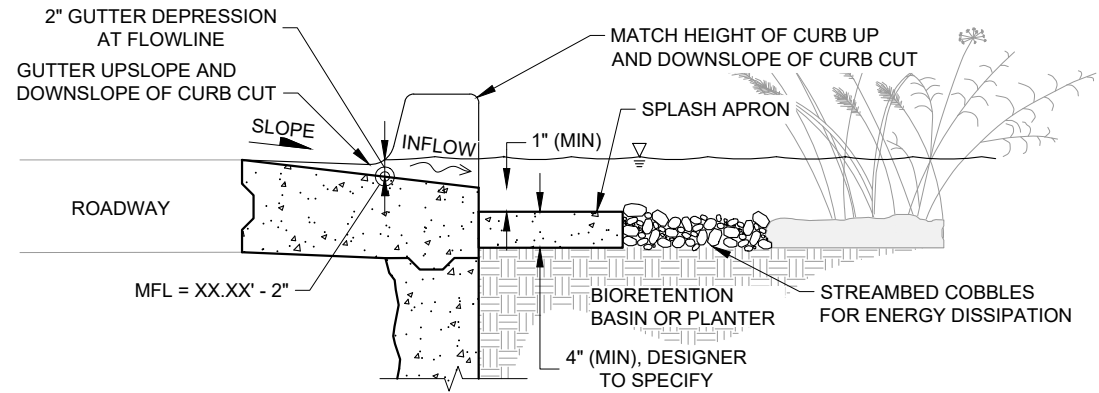

SECTION A

INLET - CURB CUT TYPE 1

EDGE TREATMENTS							INLETS			OUTLETS			AGGREGATE STORAGE COMPONENTS	UNDERDRAINS			CHECK DAM		MONITORING				
NOTES	COMPONENTS						NOTES	COMPONENTS			NOTES	COMPONENTS			NOTES	COMPONENTS	NOTES	COMPONENTS					
BC	BC	BC	BC	BC	BC	BC	BC	BC	BC	BC	BC	BC	BC	BC	BC	BC	BC	BC	BC	BC			
1.1	1.2	1.3	1.4	1.5	1.6	1.7	2.1	2.2	2.3	2.4	3.1	3.2	3.3	3.4	4.1	5.1	5.2	5.3	6.1	6.2	7.1	7.2	7.3



**GREEN INFRASTRUCTURE
TYPICAL DETAILS**
SAN FRANCISCO PUBLIC UTILITIES COMMISSION

DATE
JANUARY 2023
VERSION
3.0
REVISED

**BIORETENTION COMPONENTS
INLETS
CURB CUT WITH GUTTER MODIFICATION**

DWG NO.
**BC
2.2**

NOT FOR CONSTRUCTION - REFER TO USER GUIDE

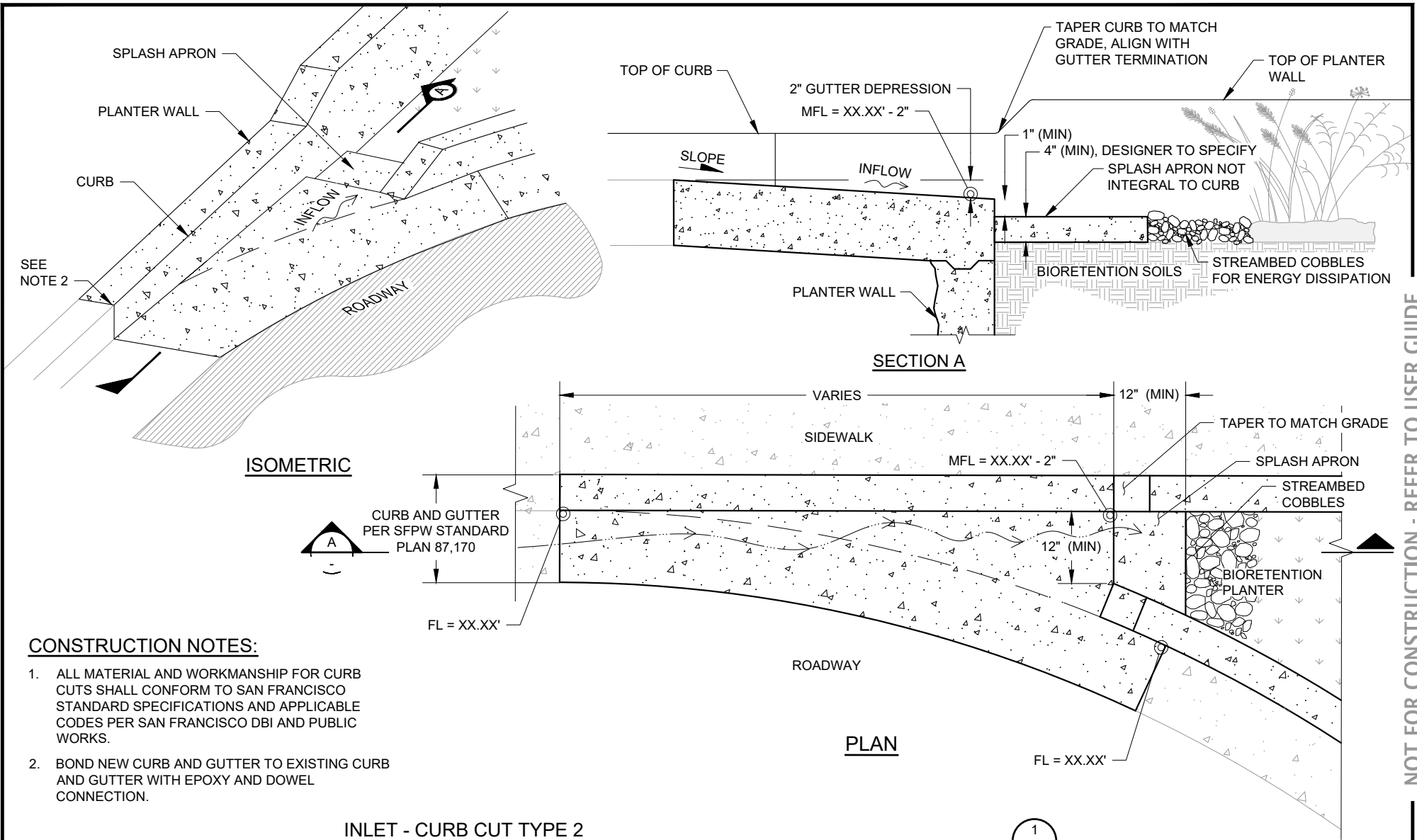

CONSTRUCTION NOTES:

1. ALL MATERIAL AND WORKMANSHIP FOR CURB CUTS SHALL CONFORM TO SAN FRANCISCO STANDARD SPECIFICATIONS AND APPLICABLE CODES PER SAN FRANCISCO DBI AND PUBLIC WORKS.
2. BOND NEW CURB AND GUTTER TO EXISTING CURB AND GUTTER WITH EPOXY AND DOWEL CONNECTION.

INLET - CURB CUT TYPE 2

EDGE TREATMENTS							INLETS			OUTLETS			AGGREGATE STORAGE COMPONENTS	UNDERDRAINS			CHECK DAM		MONITORING				
NOTES	COMPONENTS						NOTES	COMPONENTS		NOTES	COMPONENTS		BC	NOTES	COMPONENTS		NOTES	COMPONENTS					
BC 1.1	BC 1.2	BC 1.3	BC 1.4	BC 1.5	BC 1.6	BC 1.7	BC 2.1	BC 2.2	BC 2.3	BC 2.4	BC 3.1	BC 3.2	BC 3.3	BC 3.4	BC 4.1	BC 5.1	BC 5.2	BC 5.3	BC 6.1	BC 6.2	BC 7.1	BC 7.2	BC 7.3



**GREEN INFRASTRUCTURE
TYPICAL DETAILS**
SAN FRANCISCO PUBLIC UTILITIES COMMISSION

DATE
JANUARY 2023
VERSION
3.0
REVISED

**BIORETENTION COMPONENTS
INLETS
CURB CUT AT BULB OUT**

DWG NO.
**BC
2.3**

NOT FOR CONSTRUCTION - REFER TO USER GUIDE

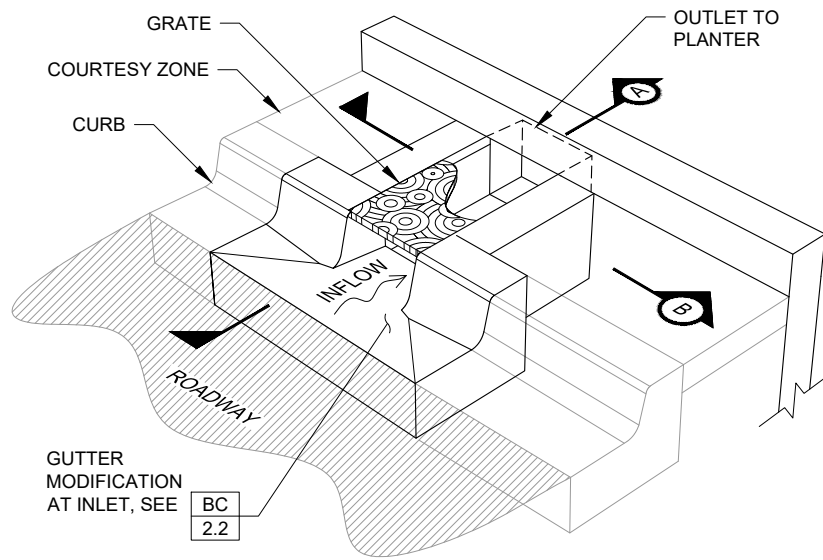

ISOMETRIC

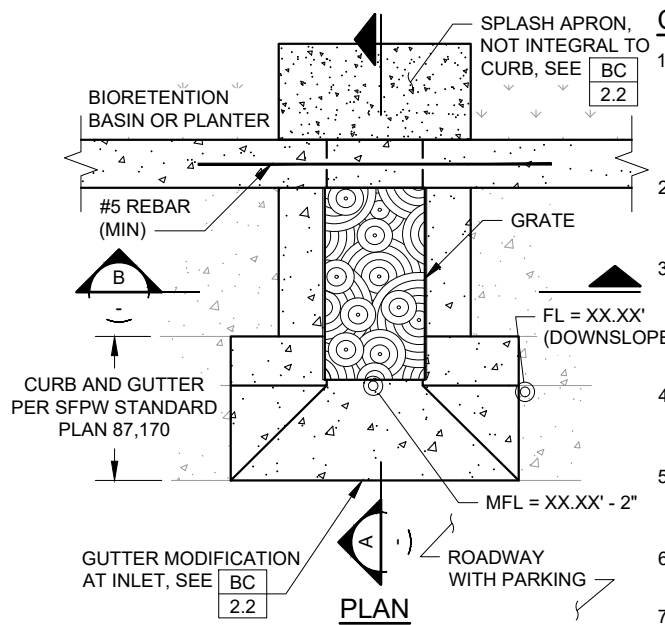

PLAN

CONSTRUCTION NOTES:

1. ALL MATERIAL AND WORKMANSHIP FOR TRENCH DRAIN ASSEMBLY SHALL CONFORM TO SAN FRANCISCO STANDARD SPECIFICATIONS AND APPLICABLE CODES PER SAN FRANCISCO DBI AND PUBLIC WORKS.
2. SLOPE TO PROVIDE AT LEAST 1 INCH DROP OVER LENGTH OF CHANNEL OR A MINIMUM OF 2 PERCENT, WHICHEVER IS LARGER.
3. ALL TRENCH GRATES SHALL BE REMOVABLE, RATED PER THE ANTICIPATED LOADING, AND BOLTED IN PLACE OR OUTFITTED WITH APPROVED TAMPER-RESISTANT LOCKING MECHANISM, FLUSH OR RECESSED IN GRATE.
4. BOND NEW CURB AND GUTTER TO EXISTING CURB AND GUTTER WITH EPOXY AND DOWEL CONNECTION.
5. HORIZONTAL CONTROL JOINTS SHALL BE PROVIDED EVERY 10 LINEAR FEET, OR PER MANUFACTURER'S RECOMMENDATIONS.
6. APPLY EPOXY BONDING AGENT AT ALL TRENCH DRAIN CONSTRUCTION COLD JOINTS.
7. INLET CURB CUT AND CONCRETE CHANNEL WIDTH SHALL BE 16" (MIN) ON GUTTER SLOPE: $\geq 5\%$.

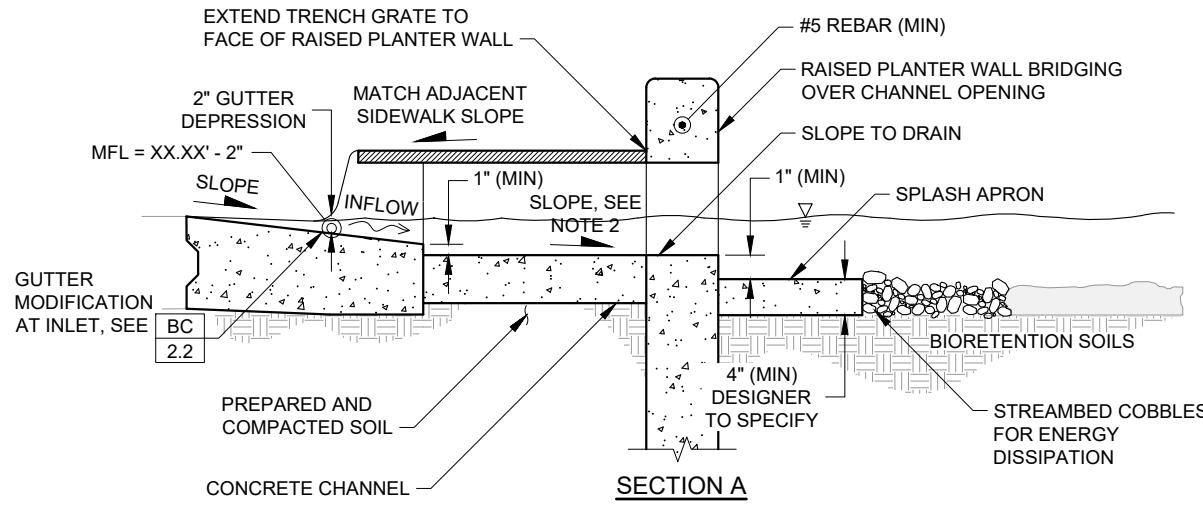

SECTION A

INLET - TRENCH DRAIN

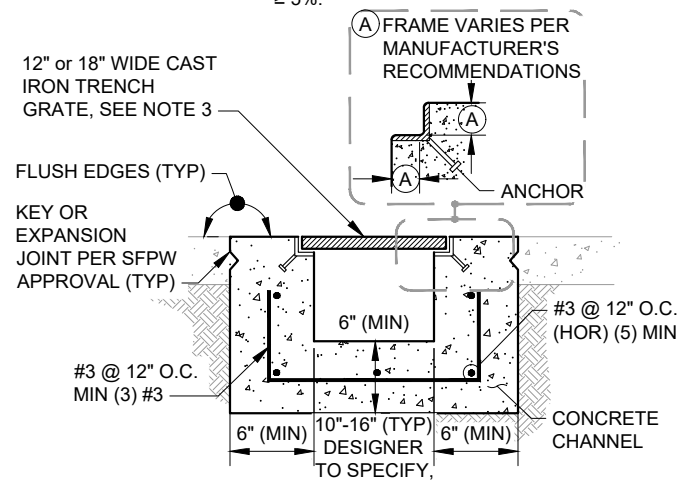

SECTION B

EDGE TREATMENTS							INLETS			OUTLETS			AGGREGATE STORAGE COMPONENTS	UNDERDRAINS			CHECK DAM		MONITORING				
NOTES	COMPONENTS						NOTES	COMPONENTS		NOTES	COMPONENTS		COMPONENTS	NOTES	COMPONENTS	NOTES	COMPONENTS	NOTES	COMPONENTS				
BC 1.1	BC 1.2	BC 1.3	BC 1.4	BC 1.5	BC 1.6	BC 1.7	BC 2.1	BC 2.2	BC 2.3	BC 2.4	BC 3.1	BC 3.2	BC 3.3	BC 3.4	BC 4.1	BC 5.1	BC 5.2	BC 5.3	BC 6.1	BC 6.2	BC 7.1	BC 7.2	BC 7.3



**GREEN INFRASTRUCTURE
TYPICAL DETAILS**

SAN FRANCISCO PUBLIC UTILITIES COMMISSION

DATE	JANUARY 2023
VERSION	3.0
REVISED	

**BIORETENTION COMPONENTS
INLETS
CURB CUT WITH TRENCH DRAINS**

DWG NO.
BC 2.4

NOT FOR CONSTRUCTION - REFER TO USER GUIDE

PURPOSE:

BIORETENTION OUTLET STRUCTURES CONVEY SURFACE AND/OR SUBSURFACE OUTFLOWS FROM A BIORETENTION FACILITY TO AN APPROVED DISCHARGE LOCATION.

DESIGNER NOTES & GUIDELINES:

1. THE DESIGNER MUST ADAPT DRAWINGS TO ADDRESS SITE-SPECIFIC CONDITIONS.
2. FOR PUBLIC PROJECTS, THE DESIGNER MUST SIZE CURB CUT, GRATE, AND OTHER OVERFLOW STRUCTURE FEATURES TO SATISFY SFPW HYDRAULIC REQUIREMENTS.
3. FOR PARCEL PROJECTS, OVERFLOW STRUCTURES SHALL BE SIZED TO MEET DBI PLUMBING CODE REQUIREMENTS, 4 INCHES MINIMUM DIAMETER. THE SIZING OF ALL OVERFLOW STRUCTURES SHALL ALSO CONSIDER MAINTENANCE ACCESS COMPATIBLE GRATE SIZES, LOCATION, AND GENERAL AESTHETICS.
4. AN OUTLET STRUCTURE OR CLEANOUT(S) THAT ALLOWS MAINTENANCE ACCESS TO ALL PIPES IS REQUIRED FOR FACILITIES WITH UNDERDRAINS.
5. FOR BMPS ON BUILDING STRUCTURE, PASSIVE GRAVITY OVERFLOW FROM BMP IS REQUIRED EITHER BY OVERFLOW PIPING FROM BMP OR BY 'FAILSAFE' BYPASS DIVERTER VALVE.
6. IF SITE CONSTRAINTS NECESSITATE STORM DRAIN PIPE IN AN AREA SUBJECT TO VEHICULAR TRAFFIC OR OTHER LOADING, APPROPRIATE COVER DEPTH AND PIPE MATERIAL MUST BE SPECIFIED.
7. OUTLET PIPES MUST BE EQUIPPED WITH CLEANOUTS, SEE CLEANOUT DETAILS (GC 5.2).
8. DESIGNER SHALL EVALUATE BUOYANCY OF STRUCTURES FOR SITE SPECIFIC APPLICATION AND SPECIFY THICKENED OR EXTENDED BASE / ANTI-FLOTATION COLLAR, AS NECESSARY.
9. SAND TRAP REQUIREMENTS (12 INCH SUMP AND CAST IRON HOOD/TRAP) MAY BE ELIMINATED WHEN OVERFLOW DIRECTLY DISCHARGES TO DOWNSTREAM (SAN FRANCISCO PUBLIC WORKS) SAND TRAP.
10. LOCATE ALL OVERFLOW PIPES AT AN ELEVATION HIGHER THAN THE SEWER HYDRAULIC GRADE LINE TO PREVENT BACKFLOW INTO THE BIORETENTION FACILITY.

DESIGNER CHECKLIST (MUST SPECIFY, AS APPLICABLE):

- OVERFLOW STRUCTURE TYPE/MATERIAL, DIAMETER, AND DEPTH
- ATRIUM GRATE MANUFACTURER, MODEL NO., AND SIZE
- SAND TRAP COMPONENTS AND DIMENSIONS
- FRAME AND GRATE TYPE, MODEL NO., AND SIZE
- CONTROL ELEVATIONS FOR OUTLET STRUCTURE RIMS
- MATERIAL AND DIAMETER FOR ALL PIPES
- WATER TIGHT CONNECTOR TYPE FOR ALL WALL PENETRATIONS (E.G., GROUTED, COMPRESSION, BOOT), SEE GC 2.9 AND GC 2.10

EDGE TREATMENTS							INLETS			OUTLETS			AGGREGATE STORAGE COMPONENTS	UNDERDRAINS			CHECK DAM		MONITORING				
NOTES	COMPONENTS						NOTES	COMPONENTS			NOTES	COMPONENTS			BC	NOTES	COMPONENTS		NOTES	COMPONENTS			
BC 1.1	BC 1.2	BC 1.3	BC 1.4	BC 1.5	BC 1.6	BC 1.7	BC 2.1	BC 2.2	BC 2.3	BC 2.4	BC 3.1	BC 3.2	BC 3.3	BC 3.4	BC 4.1	BC 5.1	BC 5.2	BC 5.3	BC 6.1	BC 6.2	BC 7.1	BC 7.2	BC 7.3



**GREEN INFRASTRUCTURE
TYPICAL DETAILS**
SAN FRANCISCO PUBLIC UTILITIES COMMISSION

DATE	JANUARY 2023
VERSION	3.0
REVISED	

**BIORETENTION COMPONENTS
OUTLETS
DESIGNER NOTES**

DWG. NO.
**BC
3.1**

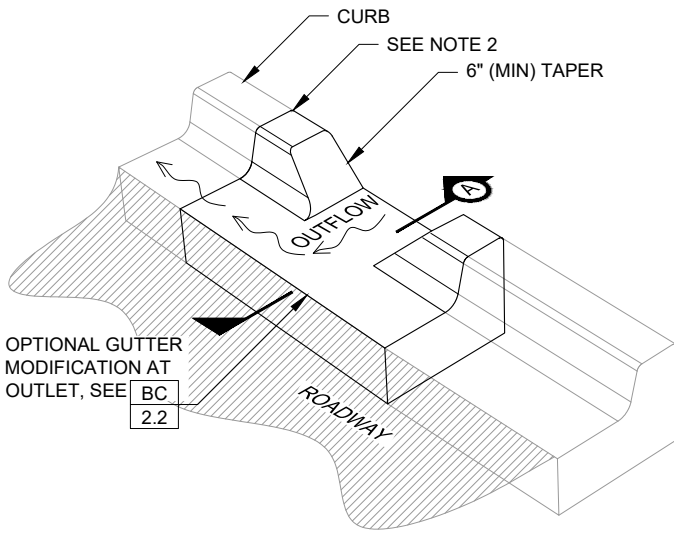

ISOMETRIC

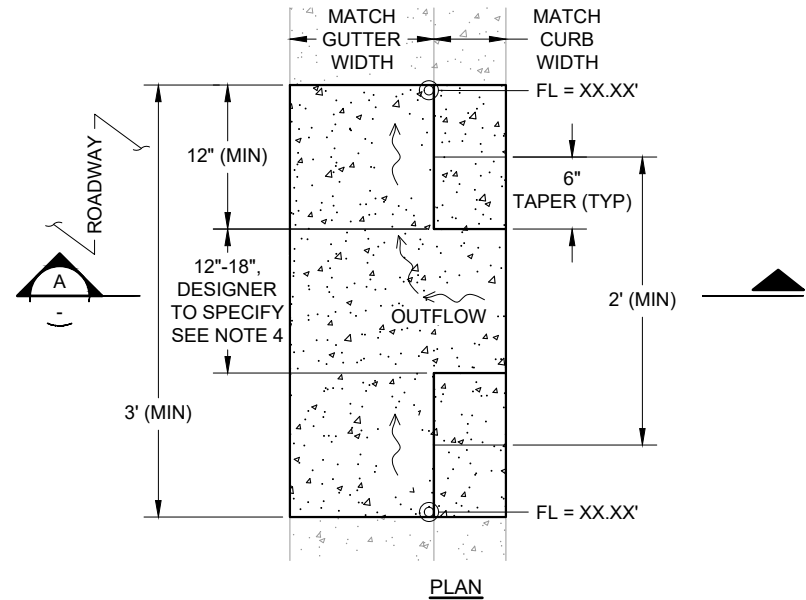

PLAN

CONSTRUCTION NOTES:

1. ALL MATERIAL AND WORKMANSHIP FOR CURB CUTS SHALL CONFORM TO SAN FRANCISCO STANDARD SPECIFICATIONS AND APPLICABLE CODES PER SAN FRANCISCO DBI AND PUBLIC WORKS.
2. BOND NEW CURB AND GUTTER TO EXISTING CURB AND GUTTER WITH EPOXY AND DOWEL CONNECTION.
3. MATCH GUTTER SLOPE UP AND DOWNSLOPE OF CURB CUT SLOPE SIMILAR TO INLET DETAIL UNLESS MODIFYING GUTTER
4. OUTLET CURB CUT WIDTH SHALL BE 18" ON GUTTER SLOPES $\geq 5\%$

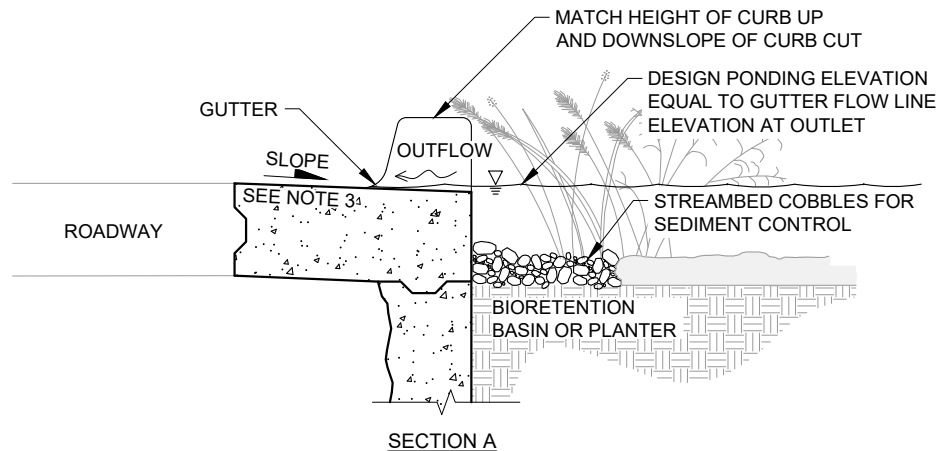

SECTION A

OUTLET - CURB CUT



EDGE TREATMENTS							INLETS				OUTLETS			AGGREGATE STORAGE COMPONENTS	UNDERDRAINS			CHECK DAM		MONITORING			
NOTES	COMPONENTS						NOTES	COMPONENTS			NOTES	COMPONENTS			NOTES	COMPONENTS	NOTES	COMPONENTS	NOTES	COMPONENTS			
BC 1.1	BC 1.2	BC 1.3	BC 1.4	BC 1.5	BC 1.6	BC 1.7	BC 2.1	BC 2.2	BC 2.3	BC 2.4	BC 3.1	BC 3.2	BC 3.3	BC 3.4	BC 4.1	BC 5.1	BC 5.2	BC 5.3	BC 6.1	BC 6.2	BC 7.1	BC 7.2	BC 7.3



**GREEN INFRASTRUCTURE
TYPICAL DETAILS**
SAN FRANCISCO PUBLIC UTILITIES COMMISSION

DATE	JANUARY 2023
VERSION	3.0
REVISED	

**BIORETENTION COMPONENTS
OUTLETS
CURB CUT**

DWG NO.
**BC
3.2**

NOT FOR CONSTRUCTION - REFER TO USER GUIDE

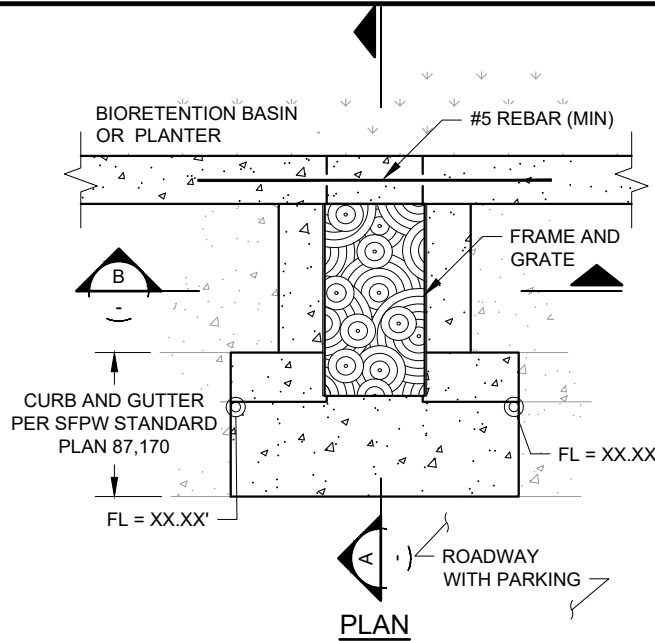
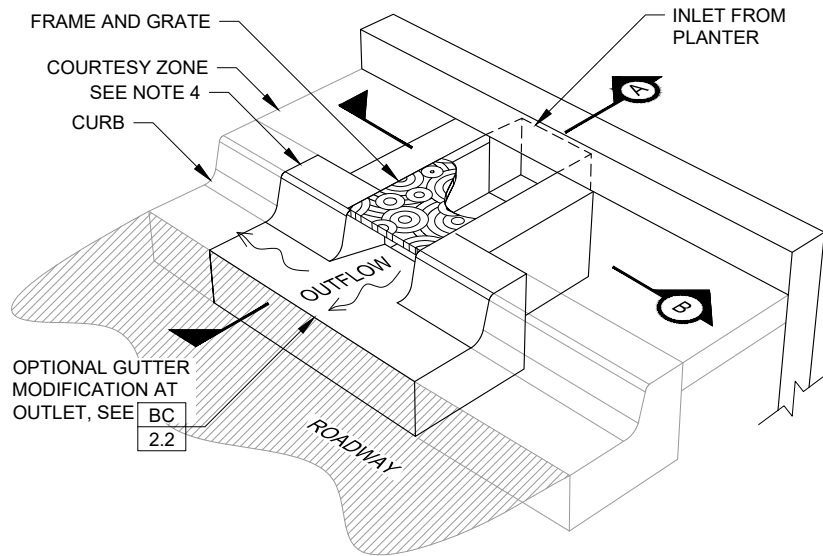

CONSTRUCTION NOTES:

1. ALL MATERIAL AND WORKMANSHIP FOR TRENCH DRAIN ASSEMBLY SHALL CONFORM TO SAN FRANCISCO STANDARD SPECIFICATIONS AND APPLICABLE CODES PER SAN FRANCISCO DBI AND PUBLIC WORKS.
2. MATCH GUTTER SLOPE UP AND DOWNSLOPE (UNLESS MODIFYING GUTTER SLOPE INLET DETAIL).
3. SLOPE TO PROVIDE AT LEAST 1 INCH DROP OVER LENGTH OF CHANNEL OR A MINIMUM OF 2 PERCENT, WHICHEVER IS LARGER.
4. ALL TRENCH GRATES SHALL BE REMOVABLE, RATED PER THE ANTICIPATED LOADING, AND BOLTED IN PLACE OR OUTFITTED WITH APPROVED TAMPER-RESISTANT LOCKING MECHANISM, FLUSH OR RECESSED IN GRATE.
5. HORIZONTAL CONTROL JOINTS SHALL BE PROVIDED EVERY 10 LINEAR FEET, OR PER MANUFACTURER'S RECOMMENDATIONS.
6. BOND NEW CURB AND GUTTER TO EXISTING CURB AND GUTTER WITH EPOXY AND DOWEL CONNECTION.
7. APPLY EPOXY BONDING AGENT AT ALL TRENCH DRAIN CONSTRUCTION COLD JOINTS.
8. INLET CURB CUT AND CONCRETE CHANNEL WIDTH SHALL BE 16" (MIN) ON GUTTER SLOPE: $\geq 5\%$.

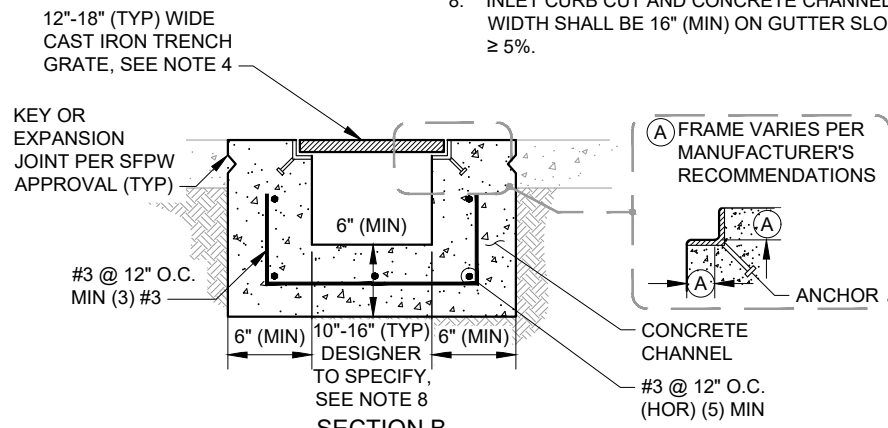
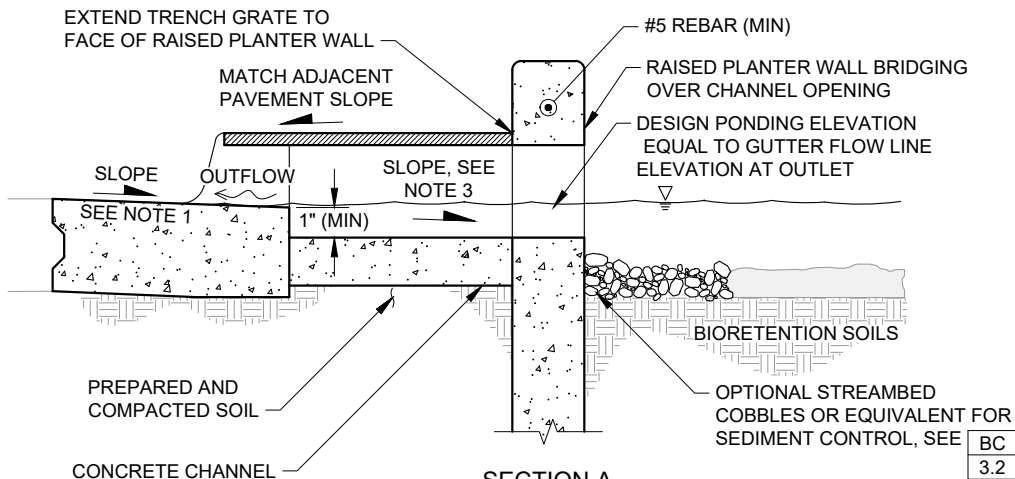

OUTLET - TRENCH DRAIN

EDGE TREATMENTS							INLETS			OUTLETS			AGGREGATE STORAGE COMPONENTS	UNDERDRAINS			CHECK DAM		MONITORING				
NOTES	COMPONENTS						NOTES	COMPONENTS			NOTES	COMPONENTS			NOTES	COMPONENTS	NOTES	COMPONENTS					
BC 1.1	BC 1.2	BC 1.3	BC 1.4	BC 1.5	BC 1.6	BC 1.7	BC 2.1	BC 2.2	BC 2.3	BC 2.4	BC 3.1	BC 3.2	BC 3.3	BC 3.4	BC 4.1	BC 5.1	BC 5.2	BC 5.3	BC 6.1	BC 6.2	BC 7.1	BC 7.2	BC 7.3



**GREEN INFRASTRUCTURE
TYPICAL DETAILS**
SAN FRANCISCO PUBLIC UTILITIES COMMISSION

DATE	JANUARY 2023
VERSION	3.0
REVISED	

**BIORETENTION COMPONENTS
OUTLETS
CURB CUT WITH TRENCH DRAIN**

DWG NO.
**BC
3.3**

NOT FOR CONSTRUCTION - REFER TO USER GUIDE

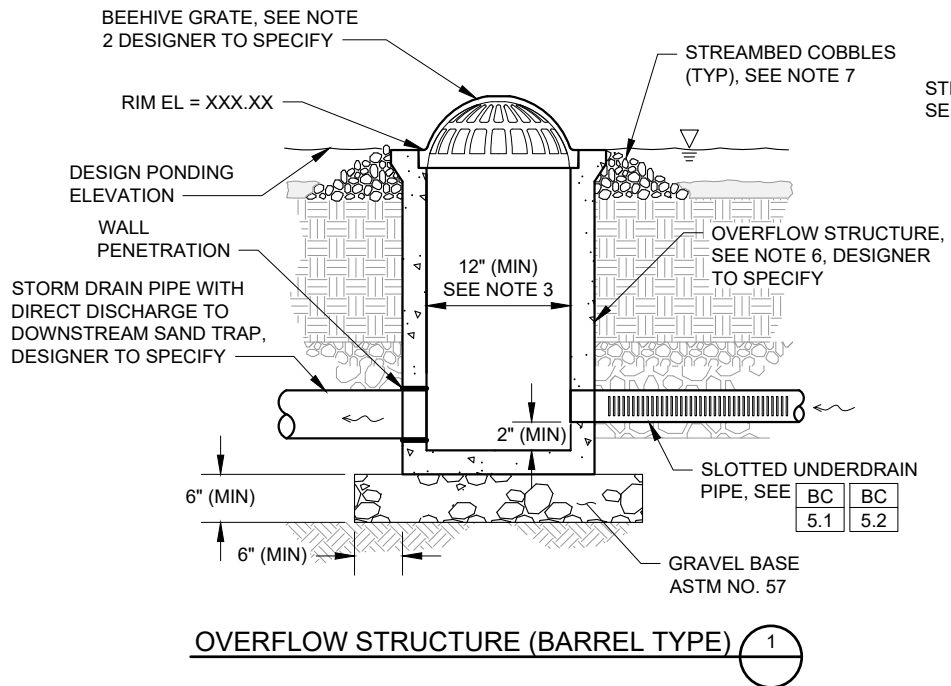

OVERFLOW STRUCTURE (BARREL TYPE) 1

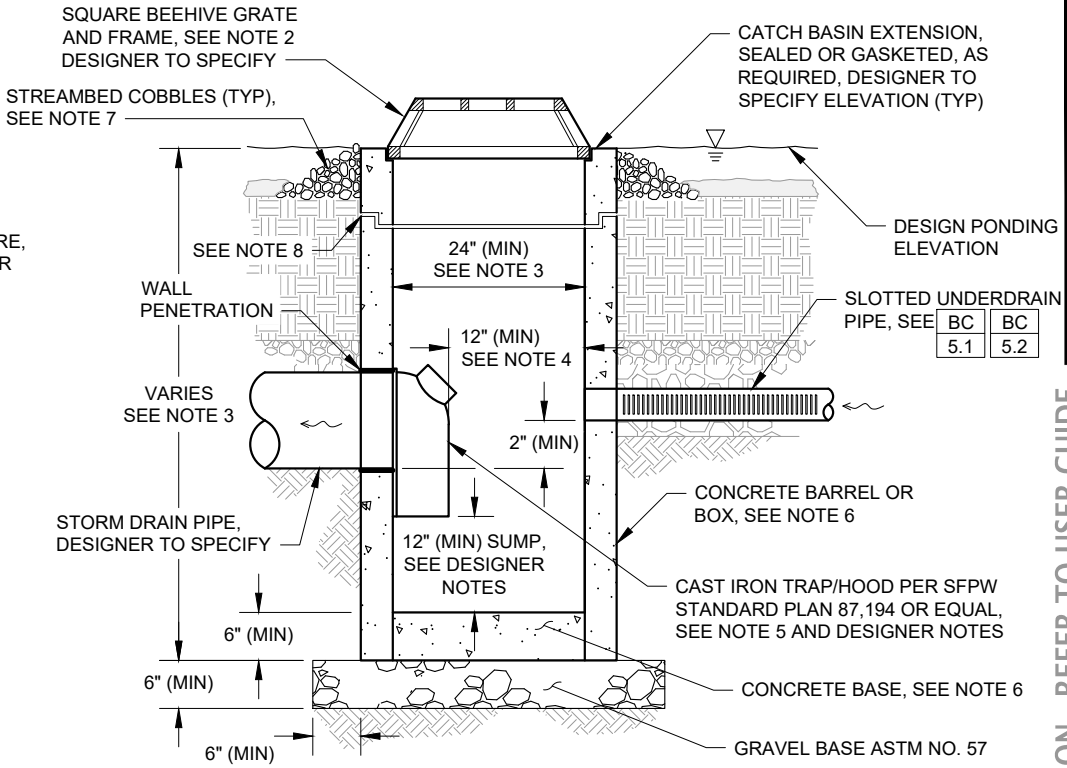

OVERFLOW STRUCTURE WITH INTERGAL SAND TRAP 2

CONSTRUCTION NOTES:

1. ALL MATERIAL AND WORKMANSHIP FOR OVERFLOW STRUCTURES SHALL CONFORM TO SAN FRANCISCO STANDARD SPECIFICATIONS AND APPLICABLE CODES PER SAN FRANCISCO DBI AND PUBLIC WORKS.
2. SIZE OF ATRIUM GRATE SHALL MATCH SIZE OF RISER SPECIFIED IN PLANS, SHALL BE REMOVABLE TO PROVIDE MAINTENANCE ACCESS, AND SHALL BE BOLTED IN PLACE OR OUTFITTED WITH APPROVED TAMPER-RESISTANT LOCKING MECHANISM. MAXIMUM GRATE OPENING SHALL BE 4 INCHES. ATRIUM GRATE SHALL BE DURABLE AND MEDIUM DUTY TRAFFIC-RELATED (MIN). CAST IRON MATERIAL REQUIRED FOR SFPUC ASSETS OR ROW APPLICATIONS.
3. IF INTERIOR DEPTH OF OVERFLOW STRUCTURE EXCEEDS 5 FEET, A PERMANENT BOLTED LADDER AND MINIMUM CLEAR SPACE OF 30 INCH BY 30 INCH IN SHALL BE PROVIDED FOR MAINTENANCE ACCESS.
4. 12 INCH (MIN) CLEARANCE WITHIN OVERFLOW STRUCTURE SHALL BE PROVIDED FOR MAINTENANCE/10\"/>

EDGE TREATMENTS							INLETS				OUTLETS				AGGREGATE STORAGE COMPONENTS	UNDERDRAINS			CHECK DAM		MONITORING		
NOTES	COMPONENTS						NOTES	COMPONENTS			NOTES	COMPONENTS			BC	NOTES	COMPONENTS		NOTES	COMPONENTS			
BC 1.1	BC 1.2	BC 1.3	BC 1.4	BC 1.5	BC 1.6	BC 1.7	BC 2.1	BC 2.2	BC 2.3	BC 2.4	BC 3.1	BC 3.2	BC 3.3	BC 3.4	BC 4.1	BC 5.1	BC 5.2	BC 5.3	BC 6.1	BC 6.2	BC 7.1	BC 7.2	BC 7.3



**GREEN INFRASTRUCTURE
TYPICAL DETAILS**
SAN FRANCISCO PUBLIC UTILITIES COMMISSION

DATE	JANUARY 2023
VERSION	3.0
REVISED	

**BIORETENTION COMPONENTS
OUTLETS
ONGRADE OVERFLOW STRUCTURES**

DWG NO.
**BC
3.4**

NOT FOR CONSTRUCTION - REFER TO USER GUIDE

DESIGNER NOTES & GUIDELINES:

1. DESIGNER SHALL INCORPORATE APPROPRIATE AGGREGATE STORAGE LAYER SECTION INTO BIORETENTION PLANTER OR BIORETENTION BASIN DETAIL.
2. TOTAL AGGREGATE STORAGE DEPTH IN COMBINED SEWER SYSTEM (INCLUDING CHOKING COURSE) SHALL BE 8 TO 12 INCHES FOR FACILITIES WITH UNDERDRAINS. DEPTH MAY BE INCREASED TO MEET PROJECT HYDROLOGIC PERFORMANCE GOALS.
3. AGGREGATE STORAGE IS OPTIONAL FOR FACILITIES NOT REQUIRING UNDERDRAINS IN COMBINED SEWER SYSTEM AREAS (I.E., WELL DRAINING SOILS WITH FIELD-TESTED INFILTRATION RATES ≥ 0.5 IN/HR).
4. FOR MS4 APPLICATIONS: AGGREGATE-FILLED TRENCH BELOW AGGREGATE LAYERS ALLOWED IF NEEDED DUE TO UNDERDRAIN SLOPE.

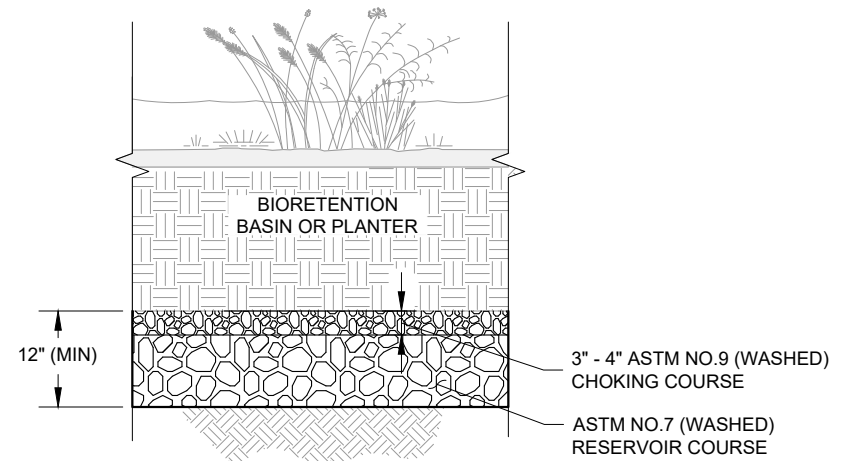

ALTERNATE 1

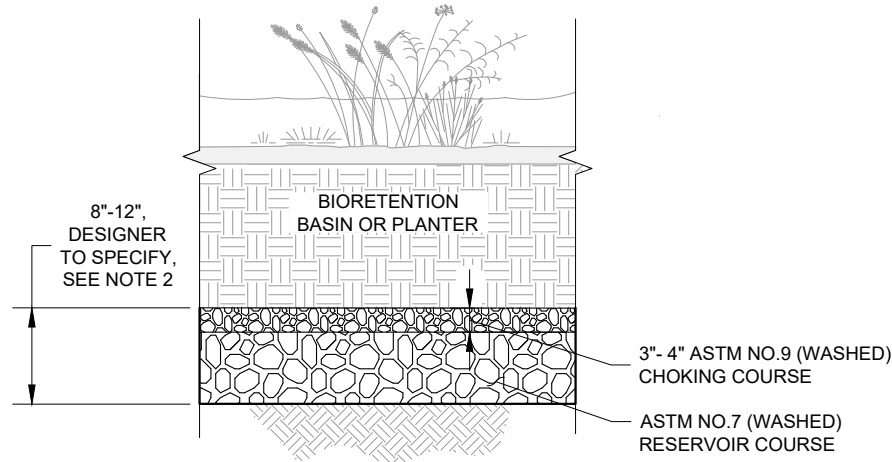

FOR USE IN COMBINED SEWER SYSTEM AREAS

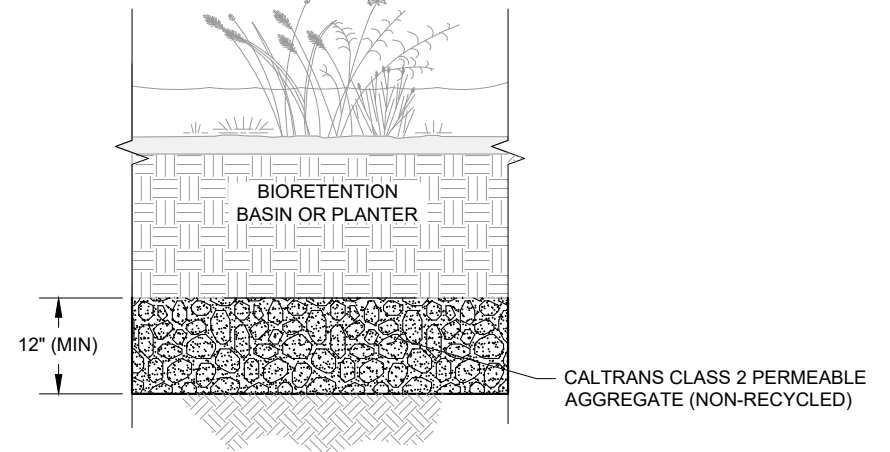

ALTERNATE 2

FOR USE IN SEPARATE SEWER SYSTEM AREAS

NOT FOR CONSTRUCTION - REFER TO USER GUIDE

EDGE TREATMENTS							INLETS				OUTLETS				AGGREGATE STORAGE COMPONENTS	UNDERDRAINS			CHECK DAM		MONITORING		
NOTES	COMPONENTS						NOTES	COMPONENTS			NOTES	COMPONENTS			BC	NOTES	COMPONENTS		NOTES	COMPONENTS			
BC 1.1	BC	BC	BC	BC	BC	BC	BC	BC	BC	BC	BC	BC	BC	BC	BC	BC	BC	BC	BC	BC	BC	BC	
	1.2	1.3	1.4	1.5	1.6	1.7	2.1	2.2	2.3	2.4	3.1	3.2	3.3	3.4	4.1	5.1	5.2	5.3	6.1	6.2	7.1	7.2	7.3



**GREEN INFRASTRUCTURE
TYPICAL DETAILS**
SAN FRANCISCO PUBLIC UTILITIES COMMISSION

DATE
JANUARY 2023
VERSION
3.0
REVISED

**BIORETENTION COMPONENTS
AGGREGATE STORAGE LAYERS**

DWG NO.
**BC
4.1**

PURPOSE:

UNDERDRAINS ARE USED TO COLLECT STORMWATER THAT HAS BEEN FILTERED THROUGH BIORETENTION SOIL AND CONVEY THAT TREATED STORMWATER TO A DESIGNATED OUTLET (E.G., PLANTER OVERFLOW STRUCTURE).

DESIGNER NOTES & GUIDELINES:

1. THE DESIGNER SHOULD INCLUDE UNDERDRAINS IN FACILITY DESIGN IN THE FOLLOWING SCENARIOS:
 - INFILTRATION IS PROHIBITED OR IMPRUDENT (E.G., FACILITY NEAR SENSITIVE INFRASTRUCTURE OR STEEP SLOPES, RISK OF CONTAMINATION IS HIGH OR SITE GROUNDWATER/SOILS ARE CONTAMINATED, THERE IS POOR INFILTRATION CAPACITY DUE TO SOILS OR HIGH GROUNDWATER).
 - SUBGRADE MEASURED (I.E., UNCORRECTED) INFILTRATION RATE IS LESS THAN 0.5 INCHES PER HOUR.
 - MAXIMUM SURFACE POOL DRAWDOWN PERIOD CANNOT BE ACHIEVED (SEE **BB 1.1**, **BP 1.1**, AND **BP 5.1**).
2. AN OUTLET STRUCTURE AND/OR CLEANOUT(S) TO ALLOW MAINTENANCE ACCESS TO ALL PIPES IS REQUIRED FOR FACILITIES WITH UNDERDRAINS.
3. UNDERDRAIN PIPE SHALL HAVE A SMOOTH INTERIOR WALL TO FACILITATE MAINTENANCE WITH PRESSURIZED WATER OR ROOT CUTTING EQUIPMENT.
4. DESIGNER SHOULD CONSIDER THE INSTALLED ELEVATION OF THE UNDERDRAIN PIPE WITHIN THE BIORETENTION FACILITIES AGGREGATE STORAGE LAYER TO PROMOTE INFILTRATION, BELOW THE UNDERDRAIN, WHEN FEASIBLE. DESIGNER SHOULD ALSO CONSIDER THE USE OF ORIFICES OR OTHER CONTROL STRUCTURES TO PROVIDE ADDITIONAL INFILTRATION AND FLOW CONTROL BENEFITS WHERE APPLICABLE.
5. PIPE MATERIAL SHALL BE DESIGNED PER SAN FRANCISCO ENVIRONMENTAL CODE (CHAPTER 5, SECTION 509 AND CHAPTER 7, SECTION 706).
6. UNDERDRAIN INVERT SHALL BE LOCATED TO ENSURE THAT THE FULL BIORETENTION SECTION (BIORETENTION SOIL MEDIA AND FULL AGGREGATE SECTION INCLUDING AGGREGATE BELOW UNDERDRAIN) DRAINS WITHIN 48 HRS (SEE **BP 1.1**.)

DESIGNER CHECKLIST (MUST SPECIFY, AS APPLICABLE):

- UNDERDRAIN MATERIAL TYPE AND SIZE
- UNDERDRAIN ELEVATION, SLOPE, AND LOCATION WITHIN BASIN OR PLANTER
- PIPE BEDDING MATERIAL SPECIFICATION (i.e. AGGREGATE STORAGE LAYER)
- DISCHARGE LOCATION TO OVERFLOW STRUCTURE
- CLEANOUT LOCATIONS AND MAINTENANCE ACCESS
- ORIFICE FLOW CONTROL STRUCTURE(S), AS APPLICABLE

EDGE TREATMENTS							INLETS				OUTLETS				AGGREGATE STORAGE COMPONENTS	UNDERDRAINS			CHECK DAM		MONITORING		
NOTES	COMPONENTS						NOTES	COMPONENTS			NOTES	COMPONENTS			BC	NOTES	COMPONENTS	NOTES	COMPONENTS				
BC 1.1	BC 1.2	BC 1.3	BC 1.4	BC 1.5	BC 1.6	BC 1.7	BC 2.1	BC 2.2	BC 2.3	BC 2.4	BC 3.1	BC 3.2	BC 3.3	BC 3.4	BC 4.1	BC 5.1	BC 5.2	BC 5.3	BC 6.1	BC 6.2	BC 7.1	BC 7.2	BC 7.3



**GREEN INFRASTRUCTURE
TYPICAL DETAILS**
SAN FRANCISCO PUBLIC UTILITIES COMMISSION

DATE	JULY 2022
VERSION	3.0
REVISED	

**BIORETENTION COMPONENTS
UNDERDRAINS
DESIGNER NOTES**

DWG NO.
**BC
5.1**

NOT FOR CONSTRUCTION - REFER TO USER GUIDE

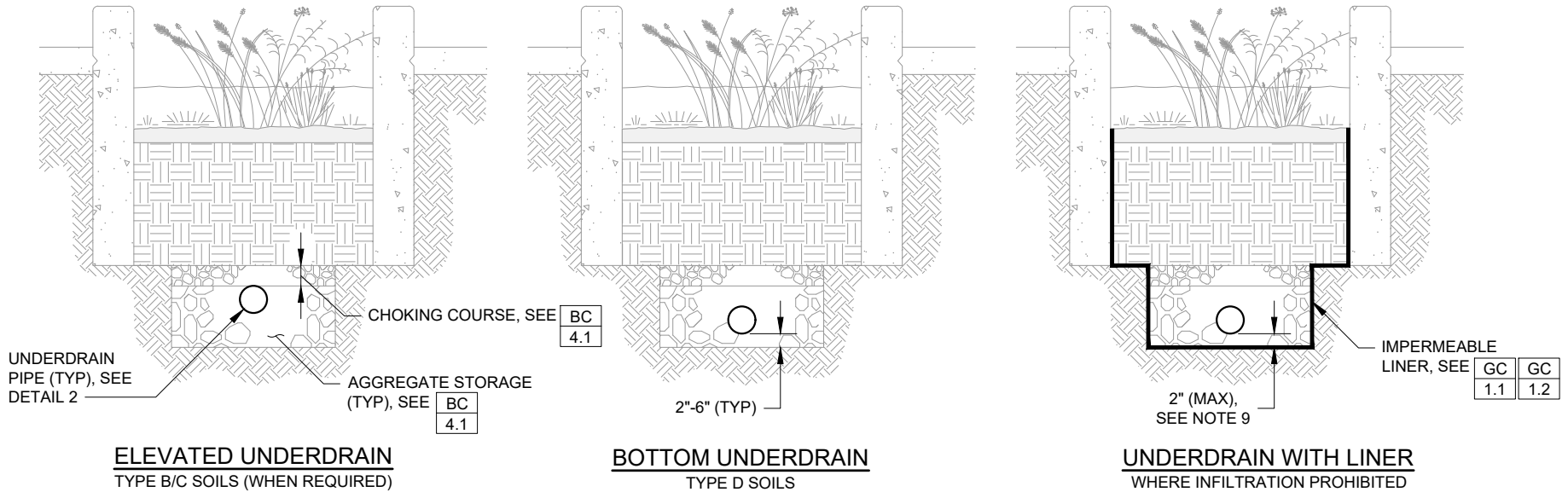

ELEVATED UNDERDRAIN
TYPE B/C SOILS (WHEN REQUIRED)

BOTTOM UNDERDRAIN
TYPE D SOILS

UNDERDRAIN WITH LINER
WHERE INFILTRATION PROHIBITED

UNDERDRAIN PLACEMENT ALTERNATIVES

CONSTRUCTION NOTES:

1. SINGLE WALL AND DUAL WALL CORRUGATED PIPE (AASHTO M252 TYPES C, S, AND D) ARE NOT ALLOWED.
2. PVC PIPE IS NOT ALLOWED FOR CITY PROJECTS AND CITY ACCEPTED ASSETS (REFER TO SF ENVIRONMENT CODE CHAPTER 5 SECTION 509 FOR ACCEPTABLE MATERIALS).
3. ALL PERFORATIONS SHALL BE SLOTTED TYPE, MEASURING 0.064 INCH WIDE (MAX), SPACED AT 0.30 INCH ON CENTER, AND PROVIDING A MINIMUM INLET AREA OF 10.0 SQUARE INCH PER LINEAR FOOT OF PIPE. OTHER SLOT CONFIGURATIONS PROVIDING A MINIMUM INLET OF 10.0 SQUARE INCHES PER LINEAR FOOT OF PIPE MAY BE SUBMITTED FOR APPROVAL BY SFPUC.
4. SLOTS SHALL BE ORIENTED PERPENDICULAR TO LONG AXIS OF PIPE, AND EVENLY SPACED AROUND CIRCUMFERENCE AND LENGTH OF PIPE.
5. SLOTTED UNDERDRAIN, CLEANOUT PIPE, AND FITTINGS SHALL BE OF SAME SIZE AND MATERIAL.
6. ALL MATERIAL AND WORKMANSHIP FOR UNDERDRAINS SHALL CONFORM TO SAN FRANCISCO STANDARD SPECIFICATIONS AND APPLICABLE CODES PER SAN FRANCISCO DBI AND PUBLIC WORKS.
7. SET CROWN OF UNDERDRAIN PIPE AT OR BELOW BOTTOM OF CHOKING COURSE. SEE DESIGNER NOTES FOR ADDITIONAL GUIDANCE ON LOCATING UNDERDRAIN PIPE IN GRAVEL STORAGE.
8. LONGITUDINAL SLOPE OF UNDERDRAIN PIPE SHALL BE 0.5% MINIMUM UNLESS APPROVED BY SFPUC (PARCEL APPLICATIONS ONLY).
9. CLEARANCE ABOVE LINER UP TO 4" MAX ALLOWED ONLY WHEN NECESSARY FOR CONSTRUCTABILITY OF ORIFICE CONTROL STRUCTURE OR OVERFLOW STRUCTURE.

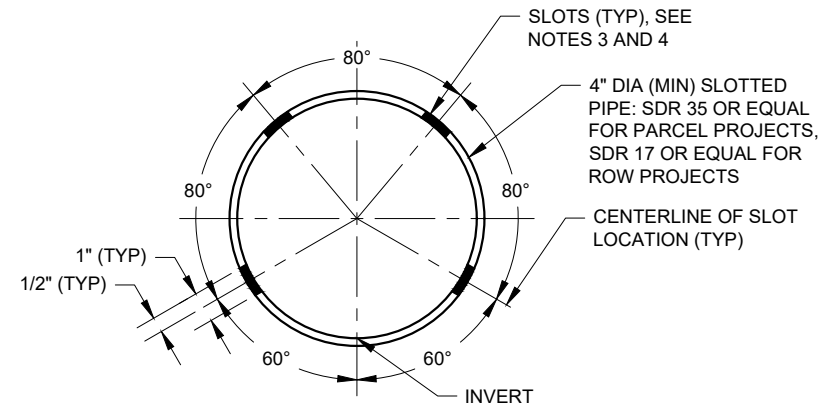

SLOTTED UNDERDRAIN PIPE

2

EDGE TREATMENTS							INLETS			OUTLETS			AGGREGATE STORAGE COMPONENTS	UNDERDRAINS			CHECK DAM		MONITORING				
NOTES	COMPONENTS						NOTES	COMPONENTS			NOTES	COMPONENTS			BC	NOTES	COMPONENTS		NOTES	COMPONENTS			
BC 1.1	BC 1.2	BC 1.3	BC 1.4	BC 1.5	BC 1.6	BC 1.7	BC 2.1	BC 2.2	BC 2.3	BC 2.4	BC 3.1	BC 3.2	BC 3.3	BC 3.4	BC 4.1	BC 5.1	BC 5.2	BC 5.3	BC 6.1	BC 6.2	BC 7.1	BC 7.2	BC 7.3



**GREEN INFRASTRUCTURE
TYPICAL DETAILS**
SAN FRANCISCO PUBLIC UTILITIES COMMISSION

DATE	JANUARY 2023
VERSION	3.0
REVISED	

**BIORETENTION COMPONENTS
UNDERDRAINS**

DWG NO.
**BC
5.2**

NOT FOR CONSTRUCTION - REFER TO USER GUIDE

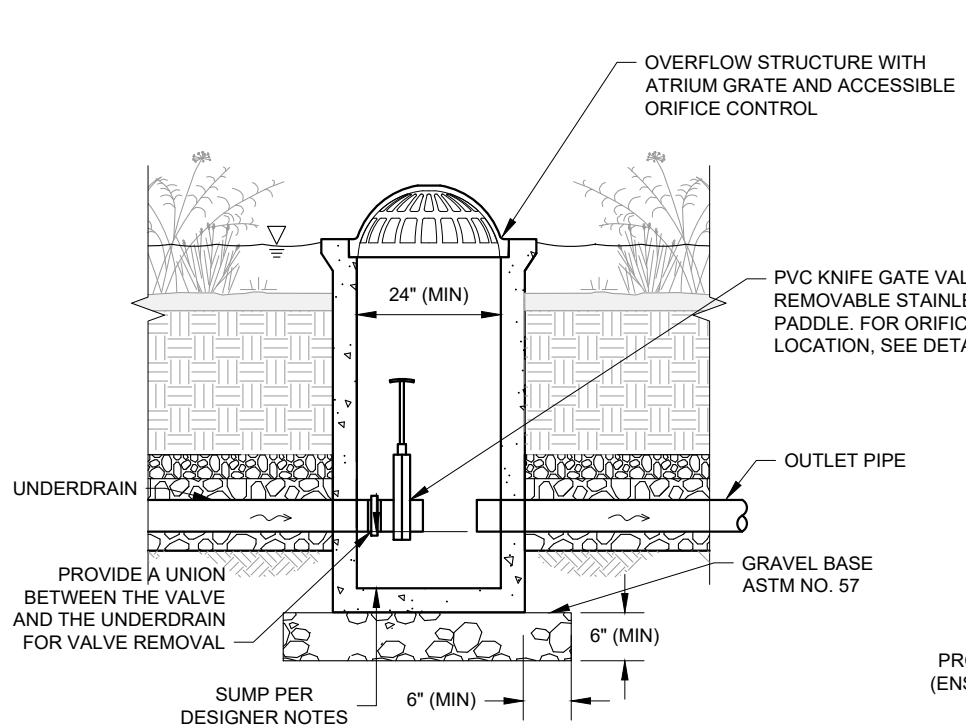

UNDERDRAIN ORIFICE CONTROL IN OVERFLOW STRUCTURE (ONE UNDERDRAIN INLET) 1

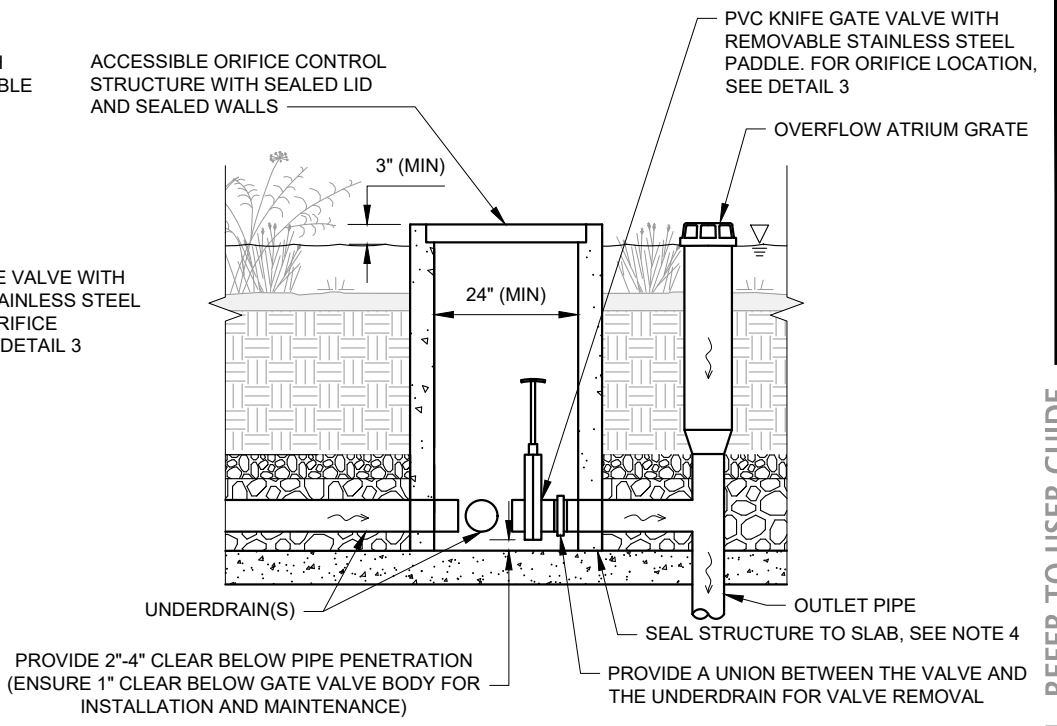

UNDERDRAIN ORIFICE CONTROL IN SEPARATE STRUCTURE (ONE OR MORE UNDERDRAIN INLETS) 2

CONSTRUCTION NOTES:

1. GATE VALVE WITH ORIFICE SHALL BE PLACED ON THE DOWNSTREAM END OF THE UNDERDRAIN PIPE WHEN LOCATED WITHIN THE OVERFLOW STRUCTURE WITH ATRIUM GRATE. GATE VALVE WITH ORIFICE SHALL BE PLACED ON OUTLET PIPE WHEN LOCATED WITHIN A SEPARATE ORIFICE CONTROL STRUCTURE WITH SEALED LID.
2. GATE VALVE HANDLE SHALL BE WITHIN 24" OF STRUCTURE RIM ELEVATION. ORIFICE CONTROL STRUCTURE SHALL BE OF SUFFICIENT WIDTH TO ALLOW ACCESS FOR VALVE REMOVAL AND PIPE FLUSHING (24" MIN DIAMETER/WIDTH).
3. MINIMUM ORIFICE SIZE SHALL BE 0.5" Ø.
4. DETAIL 2 IS SHOWN ON STRUCTURAL SLAB FOR ILLUSTRATIVE PURPOSES. PIPING CONFIGURATION MAY BE CUSTOMIZED TO BE SHOWN ON GRADE.

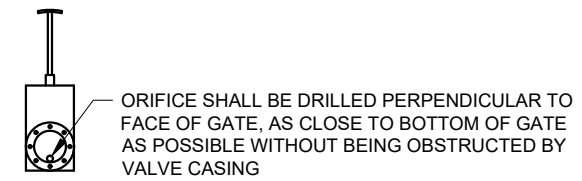

ORIFICE LOCATION ON GATE VALVE 3

EDGE TREATMENTS							INLETS				OUTLETS				AGGREGATE STORAGE COMPONENTS	UNDERDRAINS			CHECK DAM		MONITORING				
NOTES	COMPONENTS						NOTES	COMPONENTS			NOTES	COMPONENTS			BC	NOTES	COMPONENTS		NOTES	COMPONENTS					
BC 1.1	BC	BC	BC	BC	BC	BC	BC 2.1	BC	BC	BC	BC 3.1	BC	BC	BC	BC 4.1	BC 5.1	BC	BC	BC 6.1	BC	BC 7.1	BC	BC	BC 7.2	BC 7.3
	1.2	1.3	1.4	1.5	1.6	1.7		2.2	2.3	2.4		3.2	3.3	3.4		5.2	5.3		6.2						



**GREEN INFRASTRUCTURE
TYPICAL DETAILS**
SAN FRANCISCO PUBLIC UTILITIES COMMISSION

DATE	JANUARY 2023
VERSION	3.0
REVISED	

**BIORETENTION COMPONENTS
UNDERDRAINS
ORIFICE CONTROL STRUCTURES**

DWC NO.
**BC
5.3**

PURPOSE:

CHECK DAMS ARE OFTEN USED IN BIORETENTION FACILITIES AT SLOPED LOCATIONS (ALIGNED PERPENDICULAR TO THE LONGITUDINAL SLOPE OF THE FACILITY) TO REDUCE FLOW VELOCITIES (AND EROSION) THROUGH THE FACILITY AND TO PROMOTE SURFACE PONDING, SUBSURFACE STORAGE, AND INFILTRATION OF STORMWATER. CHECK DAMS CAN BE CONSTRUCTED OF A VARIETY OF MATERIALS INCLUDING CONCRETE, WOOD, METAL, ROCK, OR COMPACTED SOIL.

DESIGNER NOTES & GUIDELINES:

1. THE DESIGNER MUST ADAPT SECTION DRAWINGS TO ADDRESS SITE-SPECIFIC CONDITIONS.
2. THE DESIGNER MUST ESTABLISH THE HEIGHT AND SPACING OF CHECK DAMS BASED ON THE PONDING DEPTH REQUIRED TO MEET PROJECT HYDROLOGIC PERFORMANCE GOALS AND THE MAXIMUM DESIRED DROP FROM THE SURROUNDING GRADE TO THE FACILITY BOTTOM.
3. FOR BIORETENTION SWALES (SLOPED BOTTOM), THE AVERAGE DEPTH OF PONDING ACROSS THE FACILITY AREA MUST MEET THE REQUIRED STORAGE DEPTH.
4. CONCRETE CHECK DAM SHALL MEET STRUCTURAL REQUIREMENTS FOR LATERAL BRACING WHEN USED AS LATERAL BRACING. SEE **BC 1.6** AND **BC 1.7**.
5. MATERIALS OTHER THAN CONCRETE MAY BE ALLOWED FOR CHECK DAM WITH SFPUC APPROVAL. MUST BE DESIGNED BY STRUCTURAL ENGINEER. PROVIDE ALL CONNECTION DETAILS.

THE DESIGNER SHALL SPECIFY THE FOLLOWING, AS APPLICABLE:

- CHECK DAM TYPE AND MATERIAL
- CHECK DAM HEIGHT, WIDTH, AND ELEVATION
- CHECK DAM SPACING

NOT FOR CONSTRUCTION - REFER TO USER GUIDE

EDGE TREATMENTS							INLETS			OUTLETS			AGGREGATE STORAGE COMPONENTS	UNDERDRAINS			CHECK DAM		MONITORING				
NOTES	COMPONENTS						NOTES	COMPONENTS			NOTES	COMPONENTS			COMPONENTS	NOTES	COMPONENTS	NOTES	COMPONENTS				
BC 1.1	BC 1.2	BC 1.3	BC 1.4	BC 1.5	BC 1.6	BC 1.7	BC 2.1	BC 2.2	BC 2.3	BC 2.4	BC 3.1	BC 3.2	BC 3.3	BC 3.4	BC 4.1	BC 5.1	BC 5.2	BC 5.3	BC 6.1	BC 6.2	BC 7.1	BC 7.2	BC 7.3



**GREEN INFRASTRUCTURE
TYPICAL DETAILS**
SAN FRANCISCO PUBLIC UTILITIES COMMISSION

DATE	JANUARY 2023
VERSION	3.0
REVISED	

**BIORETENTION COMPONENTS
CHECK DAMS
DESIGNER NOTES**

DWG NO.
**BC
6.1**

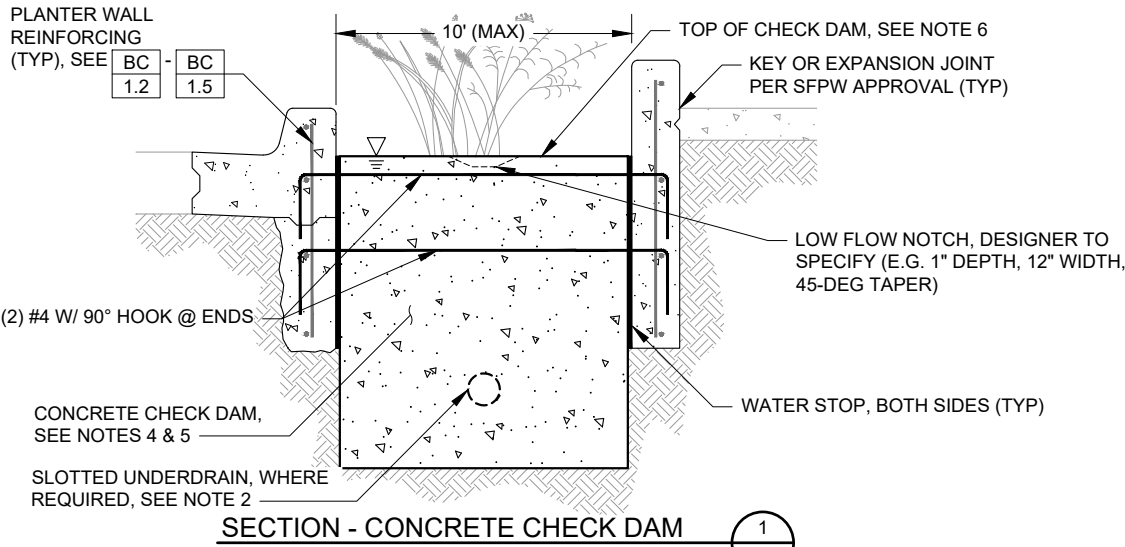

CONSTRUCTION NOTES:

1. ALL MATERIAL AND WORKMANSHIP FOR CHECK DAM ASSEMBLY SHALL CONFORM TO SAN FRANCISCO STANDARD SPECIFICATIONS AND APPLICABLE CODES PER SAN FRANCISCO DBI AND PUBLIC WORKS.
2. UNDERDRAIN TO PASS THROUGH CHECK DAM IN NON-PERFORATED.
3. PIPE FITTINGS SHALL BE USED TO ACCOMMODATE CHANGES IN GRADE, AS NEEDED.
4. CONCRETE CHECK DAM SHALL BE CONTINUOUS (NO JOINTS) AND REINFORCED WITH #4 BAR, PLACED AT 18 INCHES ON CENTER, EACH WAY.
5. CONCRETE CHECK DAM SHALL MEET STRUCTURAL REQUIREMENTS FOR LATERAL BRACING WHEN USED AS LATERAL BRACING. COORDINATE WITH ENGINEER.
6. TOP OF CHECK DAM TO BE LEVEL WITH CREST ELEVATION MATCHING PONDING ELEVATION UNLESS NOTCH SIZED TO CONVEY DESIGN FLOWS PROVIDED.
7. CONCRETE CHECK DAM TO EXTEND 3" MIN BEYOND SIDE AND BOTTOM EDGES OF AGGREGATE PER ENGINEER GUIDANCE.

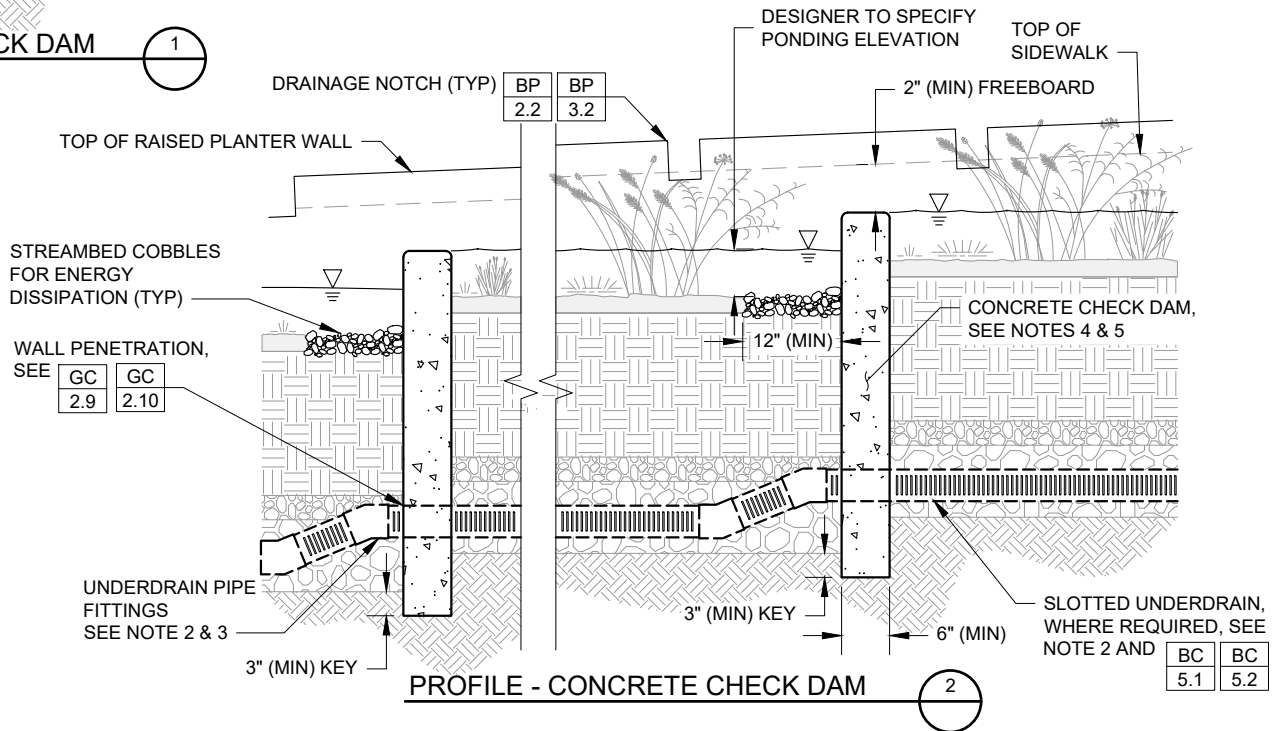

EDGE TREATMENTS							INLETS				OUTLETS				AGGREGATE STORAGE COMPONENTS	UNDERDRAINS			CHECK DAM		MONITORING		
NOTES	COMPONENTS						NOTES	COMPONENTS			NOTES	COMPONENTS			BC	NOTES	COMPONENTS	NOTES	COMPONENTS	NOTES	COMPONENTS		
BC 1.1	BC 1.2	BC 1.3	BC 1.4	BC 1.5	BC 1.6	BC 1.7	BC 2.1	BC 2.2	BC 2.3	BC 2.4	BC 3.1	BC 3.2	BC 3.3	BC 3.4	BC 4.1	BC 5.1	BC 5.2	BC 5.3	BC 6.1	BC 6.2	BC 7.1	BC 7.2	BC 7.3



**GREEN INFRASTRUCTURE
TYPICAL DETAILS**
SAN FRANCISCO PUBLIC UTILITIES COMMISSION

DATE
JANUARY 2023
VERSION
3.0
REVISED

**BIORETENTION COMPONENTS
CHECK DAMS**

DWG NO.
**BC
6.2**

PURPOSE:

BIORETENTION OUTLET MONITORING SYSTEMS ARE DESIGNED TO MONITOR FLOWS IN THE UNDERDRAIN, OVERFLOW, AND OTHER OUTLET PIPES. THESE FLOWS ARE TYPICALLY VERY SMALL, REQUIRING THE USE OF SENSITIVE EQUIPMENT (WEIRS, STILLING WELLS, AND HIGHLY SENSITIVE PRESSURE TRANSDUCERS) TO PRODUCE ACCURATE FLOW ESTIMATES. THESE GUIDELINES WILL HELP THE DESIGNER TO DESIGN A SYSTEM WHICH WILL BE CONDUCIVE TO FLOW MEASUREMENT USING THIS EQUIPMENT.

DESIGNER NOTES & GUIDELINES:

1. THE DESIGNER MUST ADAPT THE SECTION DRAWINGS TO ADDRESS SITE-SPECIFIC CONDITIONS.
2. THE DESIGNER MUST CONSULT WITH EQUIPMENT MANUFACTURER'S REPRESENTATIVE AND MONITORING PROFESSIONAL OR TECHNICIAN PRIOR TO COMPLETION OF DESIGN.
3. UNDERDRAIN AND BYPASS FLOW SHOULD BE MEASURED WITH THE USE OF VOLUMETRIC PIPE WEIRS, STILLING WELLS, AND PRESSURE TRANSDUCERS.
4. **THE OUTLET AND UNDERDRAIN PIPES SHALL BE AT LEAST 6 INCHES IN DIAMETER AT BIORETENTION MONITORING WEIR LOCATIONS.** A REDUCER COUPLING MAY BE USED TO TRANSITION FROM PIPE DIAMETERS LESS THAN 6 INCHES TO 6 INCHES MINIMUM DIAMETER PROVIDED TRANSITION OCCURS A MINIMUM OF 3 FEET UPSTREAM OF WEIR. THE DESIGNER MUST EVALUATE AND MITIGATE THE IMPACT OF THE PIPE WEIRS ON PIPE CONVEYANCE CAPACITY AND PIPE INVERT ELEVATION.
5. PRESSURE TRANSDUCERS MAY BE VENTED OR UNVENTED. IF UNVENTED, A NEARBY BAROMETRIC TRANSDUCER OF THE SAME MAKE SHOULD BE INSTALLED FOR ATMOSPHERIC PRESSURE CORRECTION.
6. WHEN MEASURING FLOW ENTERING THE MONITORING STRUCTURE:
 - PVC STILLING WELLS MUST BE VENTED ABOVE THE HIGH WATER LINE AND WATER TIGHT BELOW THE HIGH WATER LINE (OR WATER TIGHT WITHIN THE SUMP, IF PERFORATED).
 - INSTALL FLEXIBLE TUBING THROUGH FACE OF PIPE WEIR AND STILLING WELL WALL WITH WATERTIGHT FITTINGS. TUBE SHALL PASS THROUGH WEIR AND EXTEND 2 INCHES BEYOND WEIR FACE TO AVOID MEASURING WATER DEPTH NEAR NAPPE OF WEIR. TUBE SHALL PASS THROUGH THE FACE OF THE WEIR AS FAR FROM WEIR CREST AS PRACTICABLE TO AVOID IMPACTS ON FLOW DYNAMICS.
7. WHEN MEASURING FLOW EXITING THE MONITORING STRUCTURE:
 - PVC STILLING WELLS MUST BE PERFORATED BELOW THE INVERT OF THE OUTLET PIPE. PERFORATIONS SHOULD ALWAYS BE ABOVE THE TOP OF THE PRESSURE TRANSDUCER HOUSING TO PROVIDE A PERMANENT WET POOL FOR THE TRANSDUCER.
 - THE STRUCTURE SHALL BE WATER TIGHT. CALIBRATION OF THE WEIR IN THE OUTLET PIPE WILL BE DIFFICULT IF LARGE VOLUMES OF WATER ARE NEEDED TO INCREASE THE WATER LEVEL IN THE STRUCTURE TO THE INVERT OF THE PIPE WEIR.
8. THE MONITORING STRUCTURE SHOULD BE LARGE ENOUGH TO PROVIDE ACCESS FOR INSTALLATION, MAINTENANCE, AND REMOVAL OF MONITORING EQUIPMENT.
9. THE DESIGNER MUST ENSURE THAT BACKWATER CONDITIONS DO NOT OCCUR IN THE MONITORING STRUCTURE. IF THE VOLUMETRIC WEIRS ARE SUBMERGED DUE TO BACKWATER THEY WILL NOT FUNCTION PROPERLY.

DESIGNER CHECKLIST (MUST SPECIFY, AS APPLICABLE):

- MONITORING STRUCTURE TYPE/MATERIAL, DIAMETER, AND DEPTH
- PRESSURE TRANSDUCER TYPE AND SPECIFICATIONS
- WEIR TYPE, SIZE, AND RATING CURVES
- CONTROL ELEVATIONS FOR WEIRS, STILLING WELLS, AND PRESSURE TRANSDUCERS
- MATERIAL TYPE AND SIZE FOR ALL PIPES AND TUBING
- DIAGRAM WITH ALL OUTLET MONITORING ASSEMBLY COMPONENTS IDENTIFIED OR REQUEST FOR CONTRACTOR SUBMITTAL OF MONITORING ASSEMBLY

EDGE TREATMENTS							INLETS			OUTLETS			AGGREGATE STORAGE COMPONENTS	UNDERDRAINS			CHECK DAM		MONITORING											
NOTES	COMPONENTS						NOTES	COMPONENTS			NOTES	COMPONENTS			NOTES	COMPONENTS	NOTES	COMPONENTS		NOTES	COMPONENTS									
BC 1.1	BC	BC	BC	BC	BC	BC	BC 2.1	BC	BC	BC	BC 3.1	BC	BC	BC	BC 4.1	BC	BC	BC	BC 5.1	BC	BC	BC 6.1	BC	BC	BC 7.1	BC	BC	BC 7.2	BC	BC 7.3



**GREEN INFRASTRUCTURE
TYPICAL DETAILS**
SAN FRANCISCO PUBLIC UTILITIES COMMISSION

DATE	JANUARY 2023
VERSION	3.0
REVISED	

**BIORETENTION COMPONENTS
OUTLET MONITORING
DESIGNER NOTES**

DWG. NO.
**BC
7.1**

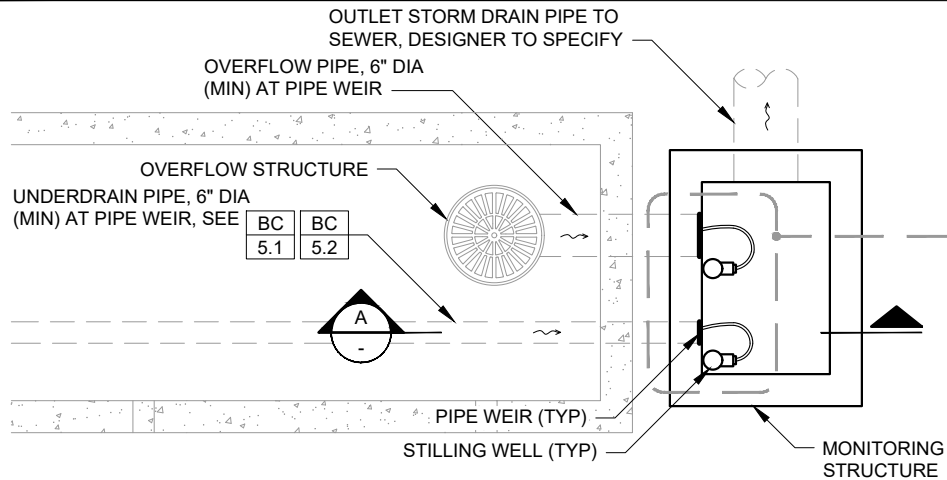

PLAN

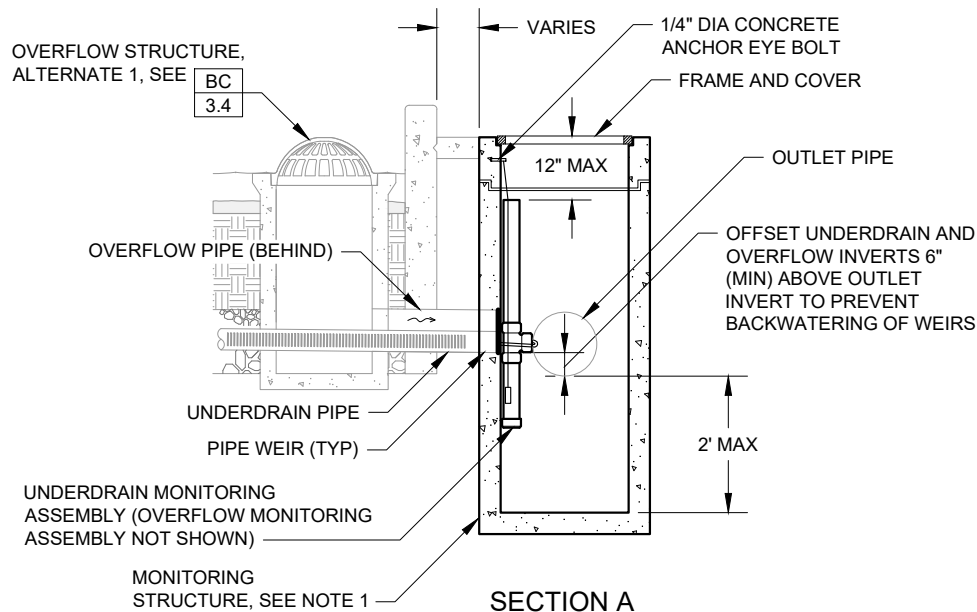

SECTION A

UNDERDRAIN AND OVERFLOW PIPE MONITORING ASSEMBLY DETAIL

(APPLIES TO BOTH ASSEMBLIES)

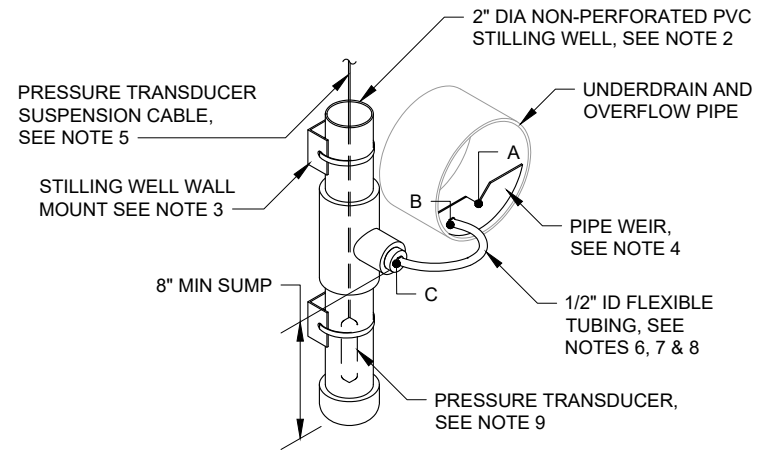

CONSTRUCTION NOTES:

1. MONITORING STRUCTURES WITH AN INTERIOR DEPTH GREATER THAN 5 FEET SHALL HAVE A MINIMUM CLEAR SPACE OF 30 INCH BY 30 INCH ACCESSIBLE BY A PERMANENT BOLTED LADDER
2. STILLING WELL SHALL BE MOUNTED VERTICALLY AND ALL FITTINGS SHALL BE WATERTIGHT.
3. ATTACH STILLING WELL WITH PREFABRICATED METAL STRUT CHANNEL AND PIPE CLAMPS (2 MINIMUM) PER MANUFACTURERS RECOMMENDATION.
4. PIPE WEIR SHALL BE INSTALLED LEVEL AND WITHIN 1 INCH OF END OF PIPE.
5. PRESSURE TRANSDUCER SUSPENSION CABLE SHALL BE 1/16 INCH COATED STAINLESS STEEL CABLE WITH FERRULED CABLE LOOP AND COMPATIBLE OVAL CARABINER FOR CONNECTION TO CONCRETE ANCHOR EYE BOLT.
6. INSTALL FLEXIBLE TUBING THROUGH FACE OF PIPE WEIR AND STILLING WELL WALL WITH WATERTIGHT FITTINGS. TUBE SHALL PASS THROUGH WEIR AND EXTEND 2 INCHES BEYOND WEIR FACE .TUBE SHALL BE INSTALLED AS FAR FROM WEIR CREST AS PRACTICABLE, SEE DESIGNER NOTES.
7. ATTACH TUBE BELOW WEIR NOTCH (POINT B SHALL BE BELOW POINT A).
8. PROVIDE NEGATIVE SLOPE IN TUBE (POINT C SHALL BE BELOW POINT B).
9. PRESSURE TRANSDUCER SHALL BE RATED FOR ZERO TO 21 PSI OF PRESSURE AND AN ACCURACY OF ±0.1 PERCENT FULL SCALE RANGE OR BETTER AT 25°C.

EDGE TREATMENTS							INLETS				OUTLETS			AGGREGATE STORAGE COMPONENTS	UNDERDRAINS		CHECK DAM		MONITORING			
NOTES	COMPONENTS						NOTES	COMPONENTS			NOTES	COMPONENTS		COMPONENTS	NOTES	COMPONENTS		NOTES	COMPONENTS			
BC 1.1	BC 1.2	BC 1.3	BC 1.4	BC 1.5	BC 1.6	BC 1.7	BC 2.1	BC 2.2	BC 2.3	BC 2.4	BC 3.1	BC 3.2	BC 3.3	BC 3.4	BC 4.1	BC 5.1	BC 5.2	BC 6.1	BC 6.2	BC 7.1	BC 7.2	BC 7.3



GREEN INFRASTRUCTURE TYPICAL DETAILS

SAN FRANCISCO PUBLIC UTILITIES COMMISSION

DATE	JANUARY 2023
VERSION	3.0
REVISED	

**BIORETENTION COMPONENTS
OUTLET MONITORING
EXTERNAL ACCESS STRUCTURE**

DWG NO.
BC 7.2

NOT FOR CONSTRUCTION - REFER TO USER GUIDE

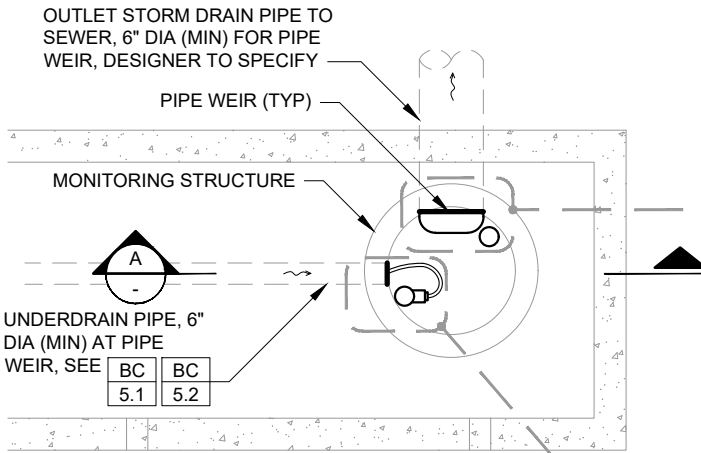

PLAN

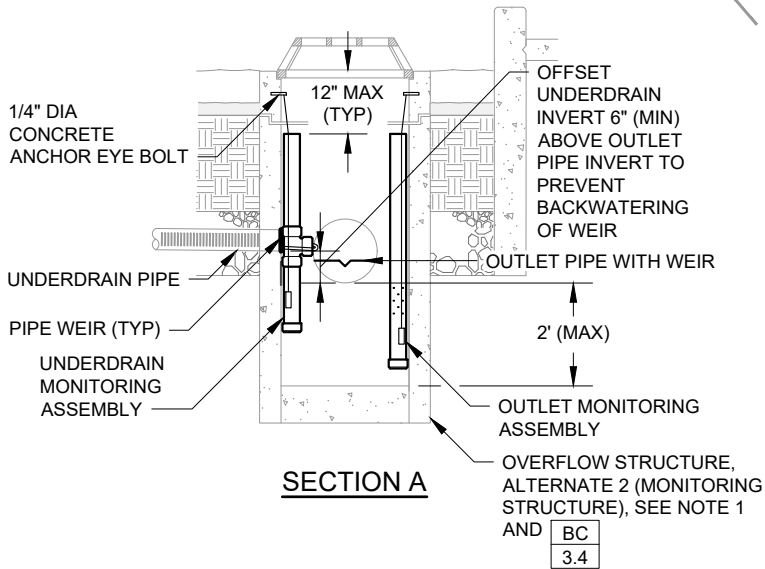

SECTION A

OUTLET PIPE MONITORING ASSEMBLY DETAIL

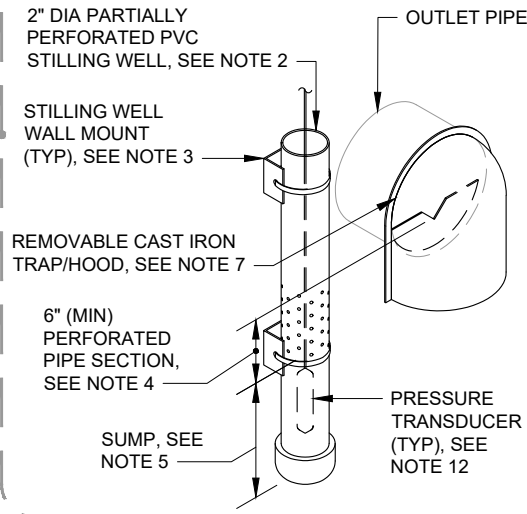

UNDERDRAIN MONITORING ASSEMBLY DETAIL

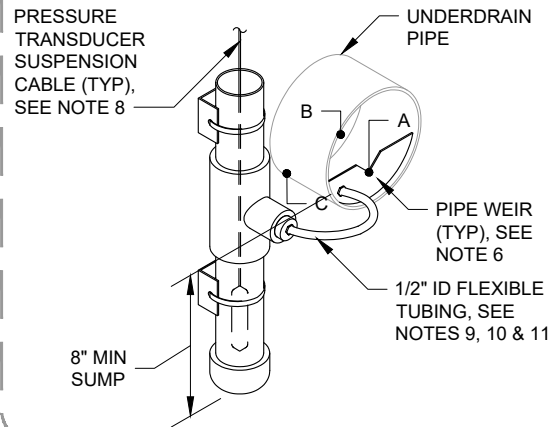

CONSTRUCTION NOTES:

- MONITORING STRUCTURES WITH AN INTERIOR DEPTH GREATER THAN 5 FEET SHALL HAVE A MINIMUM CLEAR SPACE OF 30 INCH BY 30 INCH ACCESSIBLE BY A PERMANENT BOLTED LADDER.
- STILLING WELL SHALL BE MOUNTED VERTICALLY AND ALL FITTINGS SHALL BE WATERTIGHT.
- ATTACH STILLING WELL WITH PREFABRICATED METAL STRUT CHANNEL AND PIPE CLAMPS (2 MINIMUM) PER MANUFACTURERS RECOMMENDATION.
- PROVIDE PERFORATIONS ALONG CIRCUMFERENCE OF STILLING WELL BETWEEN OUTLET PIPE INVERT AND PRESSURE TRANSDUCER SUMP. PERFORATIONS SHALL MEASURE 1/4 INCH DIAMETER (MINIMUM) AT 1 INCH (MAXIMUM) ON-CENTER SPACING, ALL DIRECTIONS.
- STILLING WELL SUMP SHALL BE NON-PERFORATED AND EXTEND 4 INCHES (MINIMUM) BELOW AND 2 INCHES (MINIMUM) ABOVE PRESSURE TRANSDUCER HOUSING TO ALLOW FOR SEDIMENT ACCUMULATION IN THE BOTTOM OF THE WELL AND PROVIDE A PERMANENT WET POOL FOR THE TRANSDUCER.
- PIPE WEIR SHALL BE INSTALLED LEVEL AND WITHIN 1 INCH OF END OF PIPE.
- REMOVABLE CAST IRON TRAP/HOOD SHALL BE NEENAH R-3701 SERIES, NEENAH R-3711 SERIES OR EQUAL. INSTALL TRAP/HOOD PER MANUFACTURERS RECOMMENDATION.
- PRESSURE TRANSDUCER SUSPENSION CABLE SHALL BE 1/16 INCH COATED STAINLESS STEEL CABLE WITH FERRULED CABLE LOOP AND COMPATIBLE OVAL CARABINER FOR CONNECTION TO CONCRETE ANCHOR EYE BOLT.
- INSTALL FLEXIBLE TUBING THROUGH FACE OF PIPE WEIR AND STILLING WELL WALL WITH WATERTIGHT FITTINGS. TUBE SHALL PASS THROUGH WEIR AND EXTEND 2 INCHES BEYOND WEIR FACE. TUBE SHALL BE INSTALLED AS FAR FROM WEIR CREST AS PRACTICABLE, SEE DESIGNER NOTES.
- ATTACH TUBE BELOW WEIR NOTCH (POINT B SHALL BE BELOW POINT A).
- PROVIDE NEGATIVE SLOPE IN TUBE (POINT C SHALL BE BELOW POINT B).
- PRESSURE TRANSDUCER SHALL BE RATED FOR ZERO TO 21 PSI OF PRESSURE AND AN ACCURACY OF ±0.1 PERCENT FULL SCALE RANGE OR BETTER AT 25°C.

EDGE TREATMENTS							INLETS				OUTLETS				AGGREGATE STORAGE COMPONENTS	UNDERDRAINS			CHECK DAM		MONITORING		
NOTES	COMPONENTS						NOTES	COMPONENTS			NOTES	COMPONENTS			BC	NOTES	COMPONENTS	NOTES	COMPONENTS	NOTES	COMPONENTS		
BC	BC	BC	BC	BC	BC	BC	BC	BC	BC	BC	BC	BC	BC	BC	BC	BC	BC	BC	BC	BC	BC	BC	
1.1	1.2	1.3	1.4	1.5	1.6	1.7	2.1	2.2	2.3	2.4	3.1	3.2	3.3	3.4	4.1	5.1	5.2	5.3	6.1	6.2	7.1	7.2	7.3



GREEN INFRASTRUCTURE TYPICAL DETAILS

SAN FRANCISCO PUBLIC UTILITIES COMMISSION

DATE
JANUARY 2023

VERSION
3.0

REVISED

BIORETENTION COMPONENTS

OUTLET MONITORING

INTERNAL CATCH BASIN MONITORING

DWG. NO.
BC
7.3

NOT FOR CONSTRUCTION - REFER TO USER GUIDE

PURPOSE:

INFILTRATION GALLERIES, ALSO KNOWN AS DRY WELLS, STORMWATER DRAINAGE WELLS, AND SEEPAGE PITS, CONTROL PEAK FLOWS AND VOLUMES OF STORMWATER RUNOFF THROUGH SUBSURFACE STORAGE AND INFILTRATION INTO NATIVE SOIL. WATER IS ALSO TREATED AS IT FILTERS THROUGH THE GRAVEL, SAND (IF PROVIDED), AND NATIVE SOIL.

DESIGNER NOTES & GUIDELINES:

1. THE DESIGNER MUST ADAPT PLAN AND SECTION DRAWINGS TO ADDRESS SITE-SPECIFIC CONDITIONS.
2. INFILTRATION GALLERIES ARE CONSIDERED CLASS V INJECTION WELLS AND SUBJECT TO THE U.S. EPA UNDERGROUND INJECTION CONTROL (UIC) PROGRAM. SUBSURFACE INFILTRATION SYSTEMS MUST BE REGISTERED WITH EPA REGION IX PRIOR TO COMING ONLINE.
3. INFILTRATION RATES SHALL BE EVALUATED AND CORRECTED BASED ON THE "DETERMINATION OF DESIGN INFILTRATION RATES FOR THE SIZING OF INFILTRATION-BASED GREEN INFRASTRUCTURE FACILITIES" DOCUMENT AVAILABLE UNDER SCP MATERIALS AND RESOURCES. MEASURED RATES SHALL BE AT OR ABOVE 0.5 INCHES PER HOUR, AND DESIGN RATES SHALL BE AT OR BELOW 5.0 INCHES PER HOUR. FOR SITES WHERE CALCULATED DESIGN RATES EXCEED 5.0 INCHES PER HOUR, INFILTRATION GALLERIES MAY STILL BE ALLOWED PROVIDED THAT THE RUNOFF IS FULLY TREATED UPSTREAM OF THE INFILTRATION FACILITY OR BY INSTALLING AN 18-INCH DEPTH (MIN) OF SAND MEETING ASTM C33 AT THE BASE OF THE FACILITY.
4. SUBSURFACE STORAGE DRAWDOWN TIME (I.E. TIME FOR MAXIMUM SUBSURFACE STORAGE VOLUME TO INFILTRATE INTO SUBGRADE AFTER THE END OF A STORM) SHOULD NOT EXCEED 48 HOURS. DRAWDOWN TIME IS CALCULATED AS THE MAXIMUM SUBSURFACE STORAGE DEPTH DIVIDED BY THE NATIVE SOIL INFILTRATION RATE.
5. INFILTRATION GALLERY SUBGRADES SHOULD BE LEVEL, REGARDLESS OF ANY LONGITUDINAL SLOPE OF THE SITE, TO PROMOTE EQUAL SUBSURFACE DISTRIBUTION OF RUNOFF. CHECKDAMS MAY BE IMPLEMENTED TO CREATE LEVEL TERRACED SUBGRADE BENEATH A MORE STEEPLY SLOPED SURFACE.
6. DEPENDING ON THE HEIGHT AND AREA OF THE PROPOSED INFILTRATION GALLERY, ADDITIONAL STRUCTURAL CONSIDERATIONS MAY BE REQUIRED TO ADDRESS EARTH PRESSURE AND/OR SURFACE LOADING.
7. INFILTRATION GALLERIES ARE MOST COMMONLY USED TO MANAGE STORMWATER RUNOFF FROM ROOFS AND PARKING LOTS, BUT CAN BE USED IN OTHER APPLICATIONS. RUNOFF SHOULD PASS THROUGH STORMWATER PRETREATMENT MEASURES TO REMOVE COARSE SEDIMENT THAT CAN CLOG PORE SPACES. REFER TO **IG 1.4-1.5** FOR PRETREATMENT GUIDANCE.
8. INFILTRATION GALLERIES ARE NOT APPROVED FOR RUNOFF FROM INDUSTRIAL AREAS, AREAS SUBJECT TO HIGH (GREATER THAN 15,000 VEHICLES PER DAY) TRAFFIC LOADING, AUTOMOTIVE REPAIR SHOPS, CAR WASHES, FLEET STORAGE AREAS, NURSERIES, SITES THAT STORE CHEMICALS OR HAZARDOUS MATERIALS, OR OTHER LAND USES THAT POSE A HIGH THREAT TO WATER QUALITY.
9. INFILTRATION GALLERIES SHOULD NOT BE USED IN AREAS OF KNOWN OR PRESUMED CONTAMINATED SOIL OR GROUNDWATER, AREAS WITH CURRENT OR HISTORICAL INDUSTRIAL USE, AREAS WITHIN 100 FEET OF CURRENT OR HISTORICAL UNDERGROUND STORAGE TANKS, FILLED FORMER BAY, MARSH OR CREEK AREAS, OR AREAS WITHIN 150 FEET OF A CURRENT OR HISTORICAL HIGHWAY. SEE SETBACK REQUIREMENTS TABLE ON **GEN 0.2**.

10. SMALL SYSTEMS (TYPICALLY A FEW FEET IN WIDTH) ARE KNOWN AS DRY WELLS AND ARE RECOMMENDED FOR SMALL DRAINAGE AREAS WITH LOW POLLUTANT LOADINGS, SUCH AS ROOFTOPS LESS THAN 0.25 ACRES IN SIZE. LARGER SYSTEMS (TYPICALLY 10 TO 100 FEET IN WIDTH) ARE KNOWN AS INFILTRATION GALLERIES AND CAN BE USED TO RECEIVE RUNOFF FROM DRAINAGE AREAS TYPICALLY UP TO 5 ACRES IN SIZE.
11. THE DRAWINGS PROVIDED DO NOT COVER DESIGNS THAT UTILIZE PROPRIETARY STORAGE, DISTRIBUTION, AND/OR STRUCTURAL SYSTEMS OTHER THAN PREFABRICATED DRY WELL STRUCTURES, WHICH HAVE BEEN SHOWN IN A GENERIC WAY. REFER TO THE MANUFACTURER'S RECOMMENDATIONS FOR ALL PROPRIETARY SYSTEMS.
12. INFILTRATION SYSTEMS OTHER THAN THOSE SHOWN IN THESE TECHNICAL DETAILS MAY BE ALLOWED FOR LARGE FACILITIES WITH SFPUC APPROVAL.

GENERAL UTILITY NOTES:

1. MINIMUM UTILITY SETBACKS AND PROTECTION MEASURES MUST CONFORM TO CURRENT SFPUC ASSET PROTECTION STANDARDS, OTHER GOVERNING UTILITY STANDARD, AND OTHER UTILITY PROVIDER REQUIREMENTS. SEE UTILITY CROSSING DESIGNER NOTES ON **GC 2.1**.
2. PROVIDE UTILITY TRENCH DAM, ANTI-SEEP COLLAR, OR EQUIVALENT TO PREVENT PREFERENTIAL FLOW OF WATER FROM INFILTRATIVE FACILITY INTO UTILITY TRENCH FROM CAUSING DAMAGE DOWNSTREAM. ENGINEER TO EVALUATE SITE CONDITIONS AND NEED FOR TRENCH DAM. REFER TO **GC2.12** FOR GUIDANCE ON UTILITY TRENCH DAM DESIGN.
3. PROPOSED UTILITY LINES TO BE LOCATED OUTSIDE OF FACILITY.

LAYOUT REQUIREMENTS:

1. REFER TO SHEET **GEN 0.2** AND APPENDIX C OF THE STORMWATER MANAGEMENT REQUIREMENTS FOR MORE DETAILED INFORMATION ON SITING AND DESIGN REQUIREMENTS FOR INFILTRATION-BASED BMPS.

RELATED COMPONENTS		
UTILITY CROSSINGS:	GC 2.1	GC 2.12
UTILITY CONFLICTS:	GC 3.1	GC 3.4
OBSERVATION POSTS:	GC 4.1	GC 4.3
CLEANOUTS:	GC 5.1	

NOTES			PRE-TREATMENT		LARGE SYSTEMS		MEDIUM SYSTEMS		SMALL SYSTEMS	
IG	IG	IG	IG	IG	PLAN SECTIONS		PLAN SECTIONS		PLAN SECTIONS	
1.1	1.2	1.3	1.4	1.5	IG	IG	IG	IG	IG	IG
					2.1	2.2	3.1	3.2	4.1	4.2

NOT FOR CONSTRUCTION - REFER TO USER GUIDE



**GREEN INFRASTRUCTURE
TYPICAL DETAILS**
SAN FRANCISCO PUBLIC UTILITIES COMMISSION

DATE	JANUARY 2023
VERSION	3.0
REVISED	

INFILTRATION GALLERIES
DESIGNER NOTES (1 OF 3)

DWG NO.
**IG
1.1**

ALLOWED FACILITY TYPE AND CONFIGURATION PER DMA SIZE:

DMA SIZE	DRAINAGE MANAGEMENT AREA (DMA)	FACILITY TYPES*	CONFIGURATION
SMALL	< 4,000 SF	<ul style="list-style-type: none"> • AGGREGATE-FILLED INFILTRATION GALLERY • DRYWELL 	ONLINE AND OFFLINE
MEDIUM	4,000 SF - 1 AC	<ul style="list-style-type: none"> • INFILTRATION CHAMBERS WITH AGGREGATE BACKFILL • AGGREGATE-FILLED INFILTRATION GALLERY • LARGE DIAMETER PIPE GALLERY • OPEN CHAMBER CONCRETE/PLASTIC STRUCTURE • DRYWELL NOT ALLOWED 	OFFLINE RECOMMENDED
LARGE	> 1 AC	<ul style="list-style-type: none"> • INFILTRATION CHAMBERS WITH AGGREGATE BACKFILL • OPEN CHAMBER CONCRETE/PLASTIC STRUCTURE • DRYWELL NOT ALLOWED 	OFFLINE REQUIRED

*FACILITY TYPES ARE LISTED FOR REFERENCE ONLY. ALTERNATIVE INFILTRATION FACILITY TYPES MAY BE CONSIDERED WITH APPROVAL FROM SFPUC.

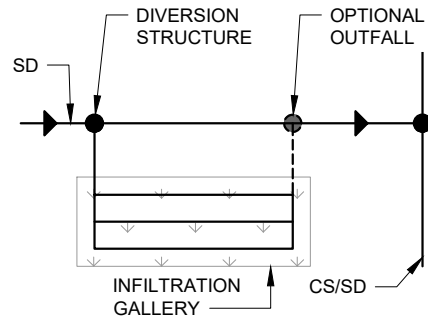

OFFLINE CONFIGURATION

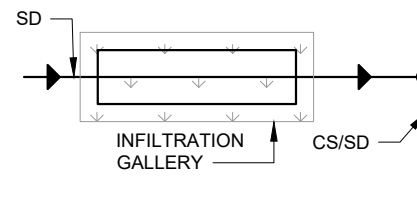

ONLINE CONFIGURATION

NOTES			PRE-TREATMENT		LARGE SYSTEMS		MEDIUM SYSTEMS		SMALL SYSTEMS	
IG	IG	IG	IG	IG	IG	IG	IG	IG	IG	IG
1.1	1.2	1.3	1.4	1.5	2.1	2.2	3.1	3.2	4.1	4.2



**GREEN INFRASTRUCTURE
TYPICAL DETAILS**
SAN FRANCISCO PUBLIC UTILITIES COMMISSION

DATE	JANUARY 2023
VERSION	3.0
REVISED	

INFILTRATION GALLERIES
DESIGNER NOTES (2 OF 3)

DWG NO.
**IG
1.2**

NOT FOR CONSTRUCTION - REFER TO USER GUIDE

DESIGNER CHECKLIST (MUST SPECIFY, AS APPLICABLE):

ALL DMA SIZES:

- TYPE AND CONFIGURATION OF INFILTRATION GALLERY:
 - INFILTRATION STORAGE STRUCTURE AND/OR MANUFACTURER
 - AGGREGATE(S)
 - FILTER FABRIC(S)
- TYPE AND SIZE OF PRETREATMENT MEASURE:
 - PRETREATMENT TYPE AND/OR MANUFACTURER MODEL
 - SIZE AND FLOW CAPACITY
- TYPE AND DESIGN OF INFILTRATION GALLERY COMPONENTS, AS APPROPRIATE:
 - INLET STRUCTURE AND/OR FLOW STRUCTURE
 - DISTRIBUTION HEADER AND/OR PERFORATED DISTRIBUTION PIPE
 - OVERFLOW AND/OR PERFORATED COLLECTION PIPE STRUCTURES, ETC.
 - CLEANOUTS
- CONSTRUCTION-LEVEL PLAN VIEW:
 - FULL SYSTEM LAYOUT AND CONFIGURATION
 - DIMENSIONS: WIDTH, LENGTH, PIPE LENGTH, SPACING, ETC.
 - COMPONENT LABELS AND DETAILS REFERENCE

- CONSTRUCTION-LEVEL CROSS-SECTION(S):
 - SYSTEM DEPTH, SOIL COVER, PIPE LAYOUT AND ROUTING, STRUCTURE(S), ETC.
 - AGGREGATE STORAGE LAYER(S) AND MATERIAL SPECIFICATION
 - STRUCTURE AND CLEANOUT: RIMS, INVERTS, MATERIAL & SIZE
 - GROUND SLOPES
- SETBACK DIMENSIONS TO:
 - BEDROCK (OR OTHER RESTRICTIVE LAYER)
 - SEASONAL HIGH GROUNDWATER TABLE
 - PROPERTY LINES
 - FOUNDATIONS
 - UTILITIES (E.G., WATER SUPPLY WELLS, SEWER MAINS, ETC.)
 - GROUND SLOPES OF 15% OR GREATER, AS APPLICABLE

MEDIUM AND LARGE DMA, ADDITIONAL ITEMS:

- DIVERSION STRUCTURE, AS NEEDED FOR OFFLINE CONFIGURATION
- EDGE LINER/WATER BARRIER, WHERE REQUIRED BY GEOTECH
- WATER QUALITY/FLOWRATE OF PRETREATMENT MEASURE
- CONSTRUCTION-LEVEL PLAN VIEW, CROSS-SECTION, AND PROFILE
- OBSERVATION WELLS, RECOMMENDED
- FILTER SAND SPECIFICATION, IF REQUIRED
- PIPE INLET AND OUTLET: INVERTS, SLOPE, MATERIAL & SIZE
- DEFINED SURVEY POINTS AT EVERY CORNER
- CSI SPECIFICATIONS & MANUFACTURERS SPEC COORDINATION (RECOMMENDED)
- GEOTECHNICAL MEMO EVALUATING FATE OF INFILTRATED WATER

LARGE DMA, ADDITIONAL ITEMS:

- DIVERSION STRUCTURE, REQUIRED FOR OFFLINE CONFIGURATION
- OBSERVATION WELLS REQUIRED
- COORDINATION WITH MANUFACTURER, AS APPLICABLE
- FULL CSI SPECIFICATIONS (SUBMITTALS, PRODUCTS, EXECUTION) REQUIRED

HYDROGEOLOGIC ANALYSIS REQUIREMENTS:

DMA SIZE	ANALYSIS	METHOD
SMALL (< 4,000 SF)	<ul style="list-style-type: none"> • SOIL CLASSIFICATION • INFILTRATION TESTING • DEPTH TO RESTRICTIVE LAYER 	<ul style="list-style-type: none"> • EXCAVATE AT LEAST ONE TEST PIT FOR EVERY 1000 SF OF FACILITY FOOTPRINT. CLASSIFY SOILS BY VISUAL OBSERVATION AND/OR TEXTUAL ANALYSIS BY A LICENSED PROFESSIONAL. • EVALUATE INFILTRATION CAPACITY PER "DETERMINATION OF DESIGN INFILTRATION RATES FOR SIZING OF INFILTRATE-BASED GREEN INFRASTRUCTURE FACILITIES" DOCUMENT. • EXCAVATE A MINIMUM OF 5-FT BELOW THE BOTTOM OF THE INFILTRATION FACILITY TO OBSERVE EVIDENCE OF GROUNDWATER OR A RESTRICTIVE LAYER.
MEDIUM (4,000 SF - 1 AC) & LARGE (> 1 AC)	ALL ANALYSIS ABOVE + <ul style="list-style-type: none"> • FATE OF INFILTRATED WATER 	ALL METHODS ABOVE + <ul style="list-style-type: none"> • A LICENSED PROFESSIONAL SHALL EVALUATE THE SUBSURFACE FLOW PATH OF THE INFILTRATED WATER, AND DETERMINE IF IT WILL REMAIN SUBSURFACE OR IF IT WILL BE EXPRESSED AT THE SURFACE, IMPACT A SUBSURFACE STRUCTURE, OR CAUSE OTHER NEGATIVE IMPACTS TO ADJACENT STRUCTURES OR INFRASTRUCTURE. THE EVALUATION SHALL INCLUDE ANALYSIS OF ALL DOWNSTREAM ADJACENT PARCELS.

NOTES			PRE-TREATMENT		LARGE SYSTEMS		MEDIUM SYSTEMS		SMALL SYSTEMS	
IG	IG	IG	IG	IG	PLAN SECTIONS	PLAN SECTIONS	PLAN SECTIONS	PLAN SECTIONS	PLAN SECTIONS	PLAN SECTIONS
1.1	1.2	1.3	1.4	1.5	2.1	2.2	3.1	3.2	4.1	4.2



**GREEN INFRASTRUCTURE
TYPICAL DETAILS**
SAN FRANCISCO PUBLIC UTILITIES COMMISSION

DATE	JANUARY 2023
VERSION	3.0
REVISED	

INFILTRATION GALLERIES
DESIGNER NOTES (3 OF 3)

DWG NO.
**IG
1.3**

NOT FOR CONSTRUCTION - REFER TO USER GUIDE

ALLOWED PRETREATMENT TYPES PER DMA SIZE:

DMA SIZE	FACILITY TYPES ¹
SMALL (< 4,000 SF)	<ul style="list-style-type: none"> • CONCRETE CB W/ SUMP OR SAND TRAP • ANY PRETREATMENT TYPE LISTED FOR MEDIUM OR LARGE CATEGORIES
MEDIUM (4,000 SF - 1 AC)	<ul style="list-style-type: none"> • SAND-OIL INTERCEPTOR • SETTLING TANK • HYDRODYNAMIC SEPARATOR • GI BMP²
LARGE (> 1 AC)	<ul style="list-style-type: none"> • SETTLING TANK • HYDRODYNAMIC SEPARATOR • GI BMP²

NOTES:

1. PRETREATMENT TYPES ARE LISTED FOR REFERENCE ONLY. ALTERNATIVE PRETREATMENT TYPES MAY BE CONSIDERED WITH APPROVAL FROM SFPUC.
2. WHEN PRETREATMENT IS A PRECEDING GI BMP, CONNECT TO UNDERDRAIN FLOW ONLY. NO UNFILTERED FLOWS TO BE CONVEYED TO INFILTRATION GALLERY. DESIGNER TO SPECIFY.

PRETREATMENT SIZING GUIDELINES:

TYPE	SIZING
CB WITH SUMP	48" DIAMETER (MIN) 24" SUMP DEPTH (MIN)
SETTLING TANK	$L \geq Q/0.17824$ L = 12' (MIN)
HYDRODYNAMIC SEPARATOR	MANUFACTURER'S RECOMMENDED CAPACITY (CFS) $\geq Q*1.5$ (DEPTH < 10' PREFERRED, 20' MAX WITH SFPUC APPROVAL)
SAND OIL SEPARATOR	$L \times W \geq Q / 0.04456$ L = 1.5 X W (MIN)
GI BMP	PER GI SIZING CALCULATOR

• Q = PEAK FLOW TO BMP (CFS), FROM **BMP CALCULATOR STEP 6**
 • L = LENGTH
 • W = WIDTH

NOTE: PRETREATMENT SIZING IN THIS TABLE PROVIDES HIGHER TSS REMOVAL PERFORMANCE THAN STANDARD INFILTRATION GALLERY SIZING IN ORDER TO PROVIDE ADDITIONAL PROTECTION FROM SILTATION, MAINTAIN INFILTRATION CAPACITY, AND PROLONG THE LIFE OF THE FACILITY.

NOTES			PRE-TREATMENT		LARGE SYSTEMS		MEDIUM SYSTEMS		SMALL SYSTEMS	
IG	IG	IG	IG	IG	PLAN SECTIONS	PLAN SECTIONS	PLAN SECTIONS	PLAN SECTIONS	PLAN SECTIONS	PLAN SECTIONS
1.1	1.2	1.3	1.4	1.5	2.1	2.2	3.1	3.2	4.1	4.2



**GREEN INFRASTRUCTURE
TYPICAL DETAILS**
SAN FRANCISCO PUBLIC UTILITIES COMMISSION

DATE	JANUARY 2023
VERSION	3.0
REVISED	

INFILTRATION GALLERIES
PRETREATMENT GUIDANCE (1 OF 2)

DWG NO.
**IG
1.4**

NOT FOR CONSTRUCTION - REFER TO USER GUIDE

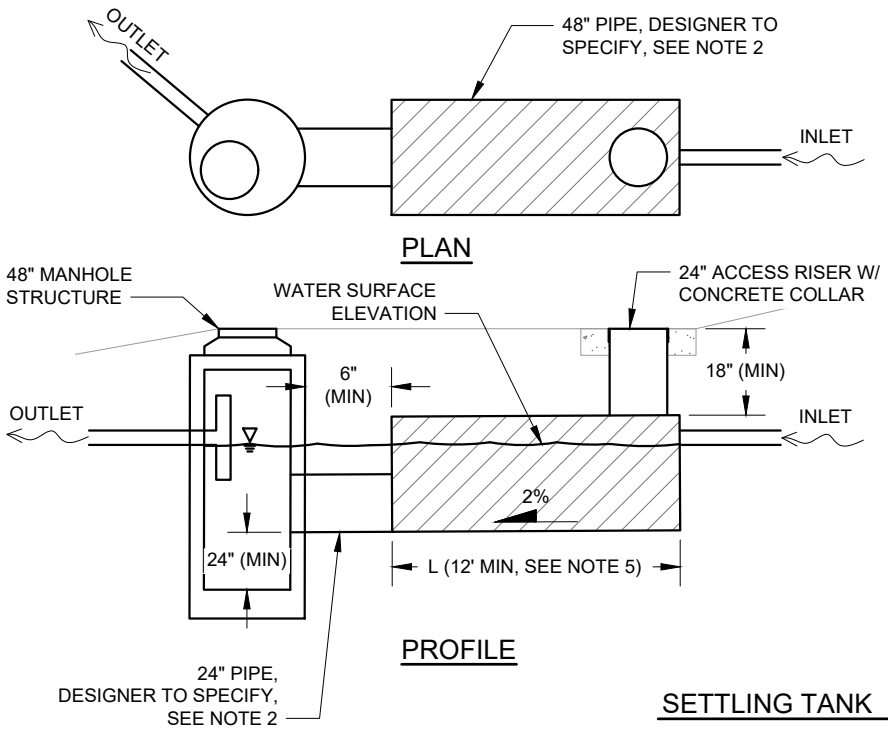

SETTLING TANK 1

CONSTRUCTION NOTES:

1. SETTLING BASIN SHALL BE BEDDED AND SEALED PER MANUFACTURER'S RECOMMENDATIONS.
2. SETTLING BASIN PIPE SHALL HAVE SMOOTH INTERIOR WALLS FOR EASE OF MAINTENANCE. STEEL REINFORCED POLYETHYLENE RECOMMENDED, HDPE OR PVC (FOR PRIVATE RESIDENCES) MAY BE ALLOWABLE.
3. ACCESS RISER AND DOWNSTREAM CATCH BASIN SHALL BE ACCESSIBLE FOR MAINTENANCE (E.G., PRESSURE WASHER AND VACTOR TRUCK, HOSE AND SHOP VAC).
4. ONE ACCESS RISER SHALL BE INSTALLED FOR EVERY 50-FOET OF LENGTH (MIN).
5. MINIMUM SETTLING BASIN LENGTH SHALL NOT BE LESS THAN 12-FOET.

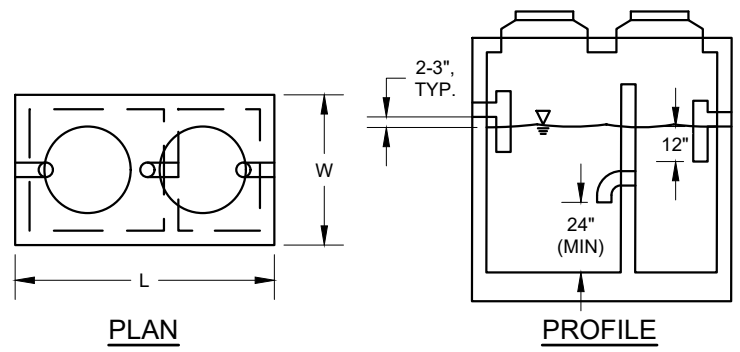

SAND OIL SEPARATOR 2

CONSTRUCTION NOTES:

1. SAND OIL SEPARATOR SHALL BE BEDDED AND BACKFILLED PER MANUFACTURER'S RECOMMENDATIONS.
2. ACCESS RISERS SHALL BE ACCESSIBLE FOR MAINTENANCE (E.G., PRESSURE WASHER AND VACTOR TRUCK).
3. ONE ACCESS RISER SHALL BE PROVIDED ON EACH SIDE OF INTERNAL BAFFLE.

NOTES			PRE-TREATMENT		LARGE SYSTEMS		MEDIUM SYSTEMS		SMALL SYSTEMS	
IG	IG	IG	IG	IG	PLAN SECTIONS	PLAN SECTIONS	PLAN SECTIONS	PLAN SECTIONS	PLAN SECTIONS	PLAN SECTIONS
1.1	1.2	1.3	1.4	1.5	2.1	2.2	3.1	3.2	4.1	4.2



**GREEN INFRASTRUCTURE
TYPICAL DETAILS**
SAN FRANCISCO PUBLIC UTILITIES COMMISSION

DATE	JANUARY 2023
VERSION	3.0
REVISED	

INFILTRATION GALLERIES
PRETREATMENT GUIDANCE (2 OF 2)

DWG NO.
**IG
1.5**

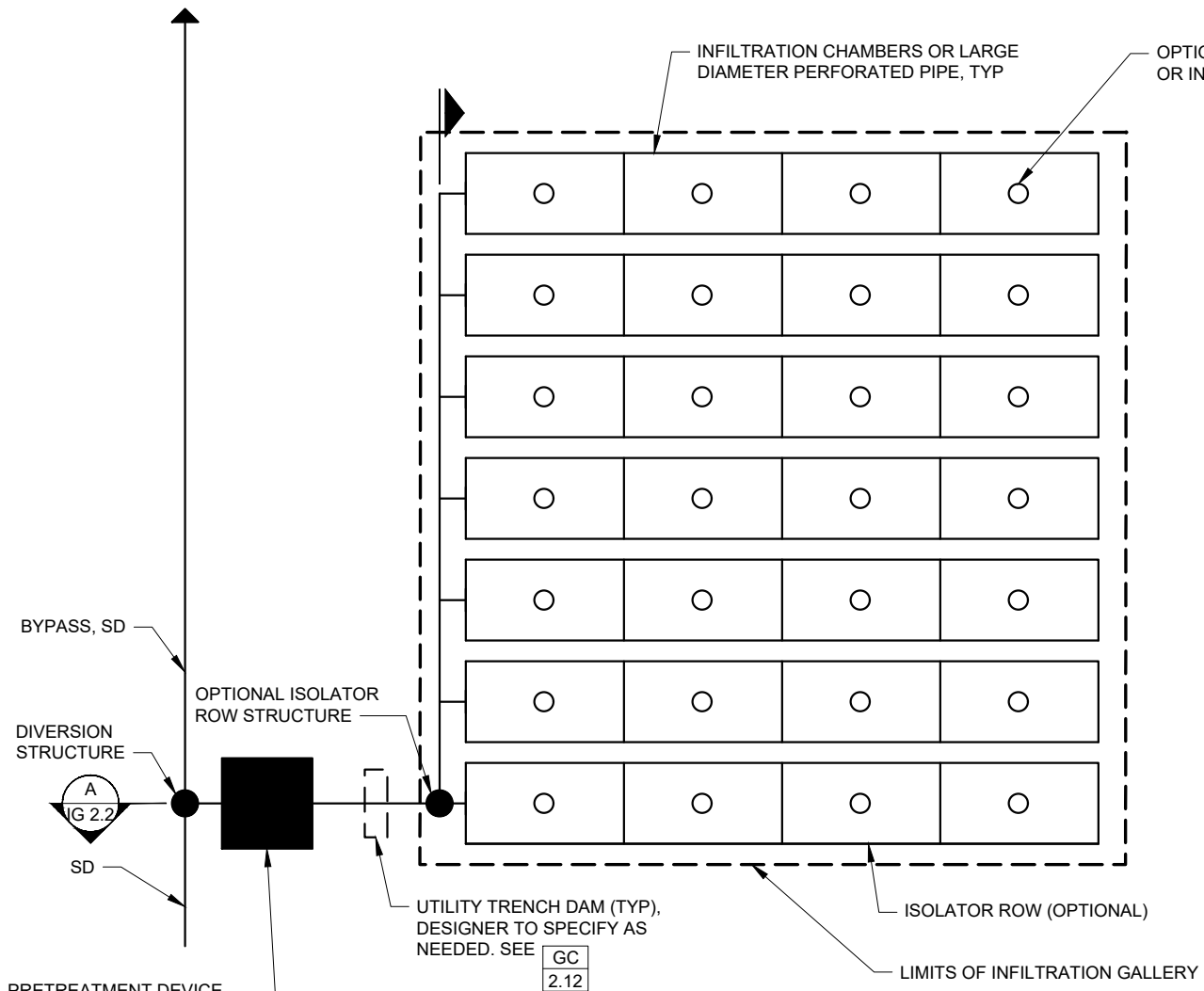

CONSTRUCTION NOTES:

1. AVOID COMPACTION AND DISTURBANCE OF EXISTING SOIL WITHIN 5 FEET ADJACENT TO AND BELOW INFILTRATION FACILITIES DURING CONSTRUCTION.
2. ROUTE OVERFLOW PIPE TO THE STORM SEWER OR TO ANOTHER BMP FOR FURTHER TREATMENT AS SHOWN ON THE DESIGN PLANS.
3. PROVIDE UTILITY TRENCH DAM OR EQUIVALENT MEASURE OUTSIDE OF THE INFILTRATION FACILITY AT PIPE PENETRATIONS TO PREVENT PREFERENTIAL FLOW FROM INFILTRATION GALLERY INTO UTILITY TRENCHES. COORDINATE WITH ENGINEER.
4. INFILTRATION CHAMBERS AND LARGE DIAMETER PIPES SHALL BE INSTALLED, BEDDED, AND BACKFILLED PER MANUFACTURER'S RECOMMENDATIONS.

SCHEMATIC PLAN - ALTERNATIVE 1 1
 CONCEPTUAL DESIGN ONLY - DESIGNER TO CUSTOMIZE

PRETREATMENT DEVICE, DESIGNER TO SPECIFY, SIZE MAY VARY DEPENDING ON TECHNOLOGY, SEE

IG	IG
1.4	1.5

NOTES			PRE-TREATMENT		LARGE SYSTEMS		MEDIUM SYSTEMS		SMALL SYSTEMS	
IG	IG	IG	IG	IG	IG	IG	IG	IG	IG	IG
1.1	1.2	1.3	1.4	1.5	2.1	2.2	3.1	3.2	4.1	4.2



**GREEN INFRASTRUCTURE
 TYPICAL DETAILS**

SAN FRANCISCO PUBLIC UTILITIES COMMISSION

DATE	JANUARY 2023
VERSION	3.0
REVISED	

**INFILTRATION GALLERIES
 LARGE SYSTEMS - PLAN**

DWG NO.
IG
2.1

NOT FOR CONSTRUCTION - REFER TO USER GUIDE

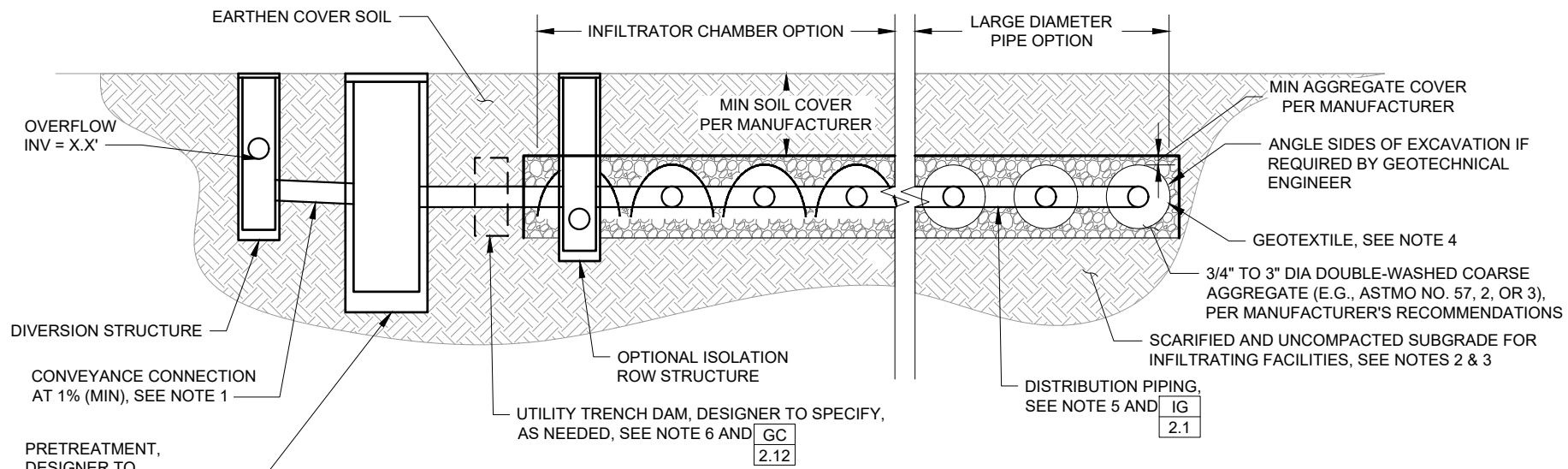

SCHEMATIC SECTION - ALTERNATIVE 1 (A)
 CONCEPTUAL DESIGN ONLY - DESIGNER TO CUSTOMIZE

CONSTRUCTION NOTES:

- REFER TO APPLICABLE SAN FRANCISCO DBI CODES AND PUBLIC WORKS REQUIREMENTS FOR CONVEYANCE CONNECTION REQUIREMENTS.
- AVOID COMPACTION AND DISTURBANCE OF EXISTING SOIL ADJACENT TO AND BELOW INFILTRATION FACILITIES DURING CONSTRUCTION.
- SCARIFY SUBGRADE TO A DEPTH OF 6 INCHES (MIN) IMMEDIATELY PRIOR TO PLACEMENT OF AGGREGATE STORAGE.
- SIDEWALLS AND TOP OF AGGREGATE STORAGE SHALL BE LINED WITH A GEOTEXTILE TO PREVENT MIGRATION OF ADJACENT SOILS INTO INFILTRATION GALLERY.
- SUBSURFACE DISTRIBUTION PIPING SHALL BE A 6 INCHES (MIN) IN DIAMETER.
- PROVIDE UTILITY TRENCH DAM OR EQUIVALENT MEASURE OUTSIDE OF THE INFILTRATION FACILITY AT PIPE PENETRATIONS TO PREVENT PREFERENTIAL FLOW FROM INFILTRATION GALLERY INTO UTILITY TRENCHES. COORDINATE WITH ENGINEER.
- INVERT OF OUTLET PIPE IN OVERFLOW STRUCTURE SHALL BE 2" BELOW THE ELEVATION OF THE TOP OF THE AGGREGATE IN THE INFILTRATION FACILITY.

NOTES			PRE-TREATMENT		LARGE SYSTEMS		MEDIUM SYSTEMS		SMALL SYSTEMS	
IG	IG	IG	IG	IG	PLAN SECTIONS	PLAN SECTIONS	PLAN SECTIONS	PLAN SECTIONS	PLAN SECTIONS	PLAN SECTIONS
1.1	1.2	1.3	1.4	1.5	2.1	2.2	3.1	3.2	4.1	4.2



**GREEN INFRASTRUCTURE
 TYPICAL DETAILS**
 SAN FRANCISCO PUBLIC UTILITIES COMMISSION

DATE
 JANUARY 2023
 VERSION
 3.0
 REVISED

INFILTRATION GALLERIES
 LARGE SYSTEMS - SECTION

DWG NO.
**IG
 2.2**

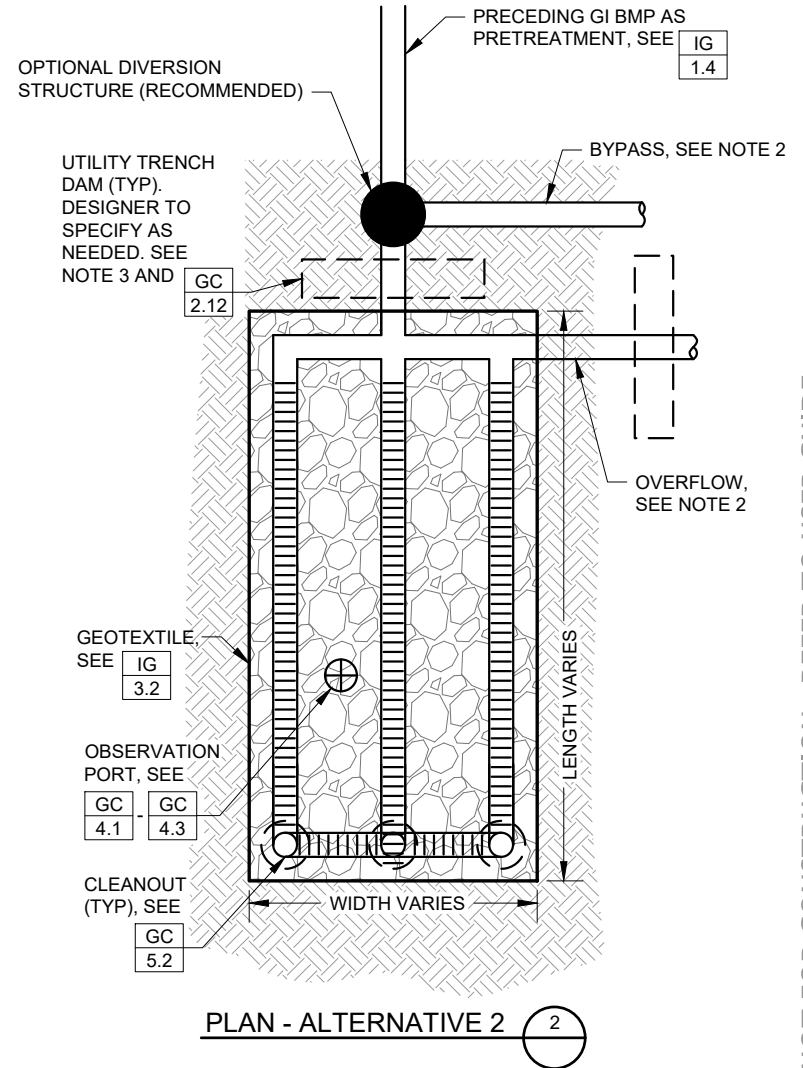
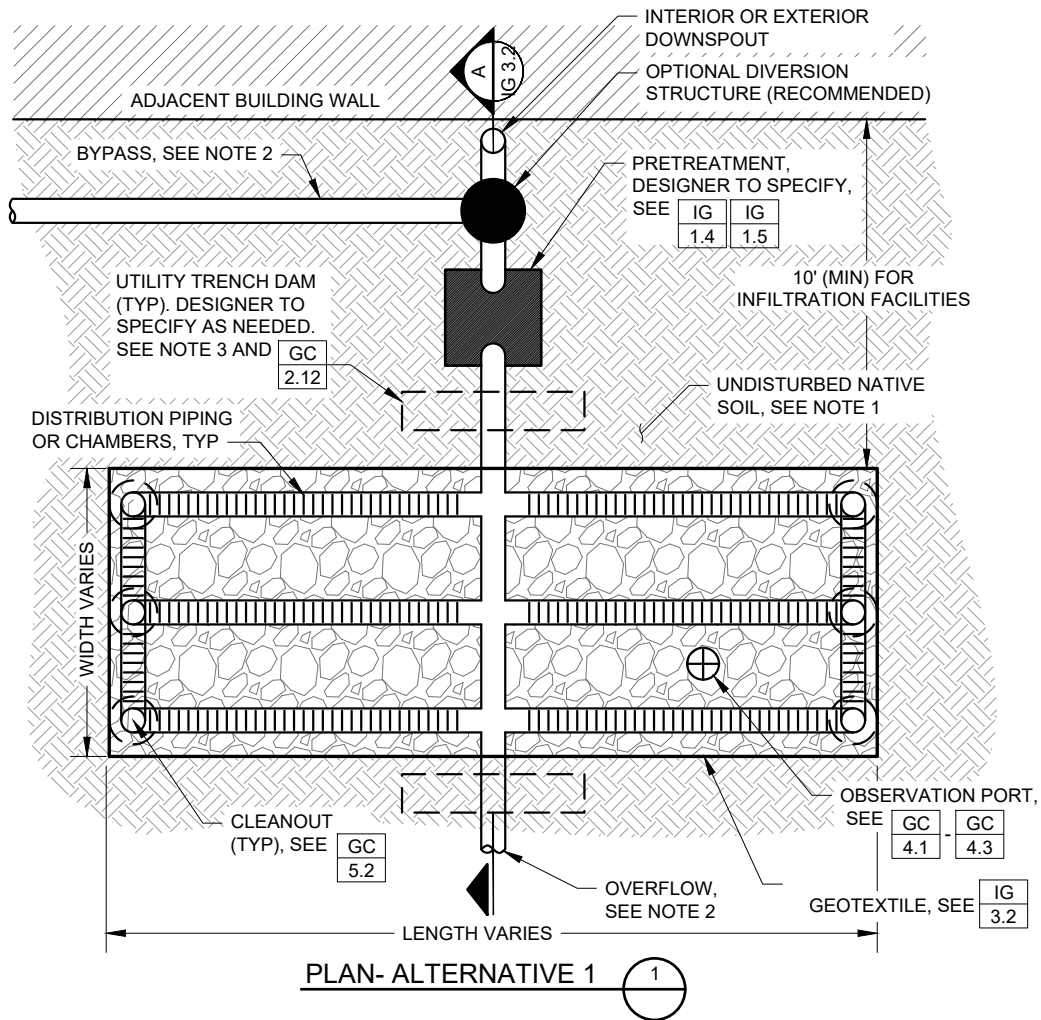

CONSTRUCTION NOTES:

1. AVOID COMPACTION AND DISTURBANCE OF EXISTING SOIL WITHIN 5 FEET ADJACENT TO AND BELOW INFILTRATION FACILITIES DURING CONSTRUCTION.
2. ROUTE OVERFLOW AND BYPASS PIPES TO THE STORM SEWER OR TO ANOTHER BMP FOR FURTHER TREATMENT AS SHOWN ON THE DESIGN PLANS.
3. PROVIDE UTILITY TRENCH DAM OR EQUIVALENT MEASURE OUTSIDE OF THE INFILTRATION FACILITY AT PIPE PENETRATIONS TO PREVENT PREFERENTIAL FLOW FROM INFILTRATION GALLERY INTO UTILITY TRENCHES. COORDINATE WITH ENGINEER.

NOTES			PRE-TREATMENT		LARGE SYSTEMS		MEDIUM SYSTEMS		SMALL SYSTEMS	
IG	IG	IG	IG	IG	PLAN SECTIONS	PLAN SECTIONS	PLAN SECTIONS	PLAN SECTIONS	PLAN SECTIONS	PLAN SECTIONS
1.1	1.2	1.3	1.4	1.5	2.1	2.2	3.1	3.2	4.1	4.2



**GREEN INFRASTRUCTURE
TYPICAL DETAILS**
SAN FRANCISCO PUBLIC UTILITIES COMMISSION

DATE	JANUARY 2023
VERSION	3.0
REVISED	

INFILTRATION GALLERIES
MEDIUM SYSTEMS - PLAN

DWG NO.
**IG
3.1**

NOT FOR CONSTRUCTION - REFER TO USER GUIDE

CONSTRUCTION NOTES:

1. REFER TO APPLICABLE SAN FRANCISCO DBI CODES AND PUBLIC WORKS REQUIREMENTS FOR CONVEYANCE CONNECTION REQUIREMENTS.
2. AVOID COMPACTION AND DISTURBANCE OF EXISTING SOIL ADJACENT TO AND BELOW INFILTRATION FACILITIES DURING CONSTRUCTION.
3. SCARIFY SUBGRADE TO A DEPTH OF 6 INCHES (MIN) IMMEDIATELY PRIOR TO PLACEMENT OF AGGREGATE STORAGE.
4. SIDEWALLS AND TOP OF AGGREGATE STORAGE SHALL BE LINED WITH A GEOTEXTILE TO PREVENT MIGRATION OF ADJACENT SOILS INTO INFILTRATION GALLERY.
5. SUBSURFACE DISTRIBUTION PIPING SHALL BE A 6 INCHES (MIN) IN DIAMETER.
6. PROVIDE UTILITY TRENCH DAM OR EQUIVALENT MEASURE OUTSIDE OF THE INFILTRATION FACILITY AT PIPE PENETRATIONS TO PREVENT PREFERENTIAL FLOW FROM INFILTRATION GALLERY INTO UTILITY TRENCHES. COORDINATE WITH ENGINEER.
7. INVERT OF OUTLET PIPE IN OVERFLOW AND/OR DIVERSION STRUCTURE SHALL BE 2" BELOW THE ELEVATION OF THE TOP OF THE AGGREGATE IN THE INFILTRATION FACILITY.

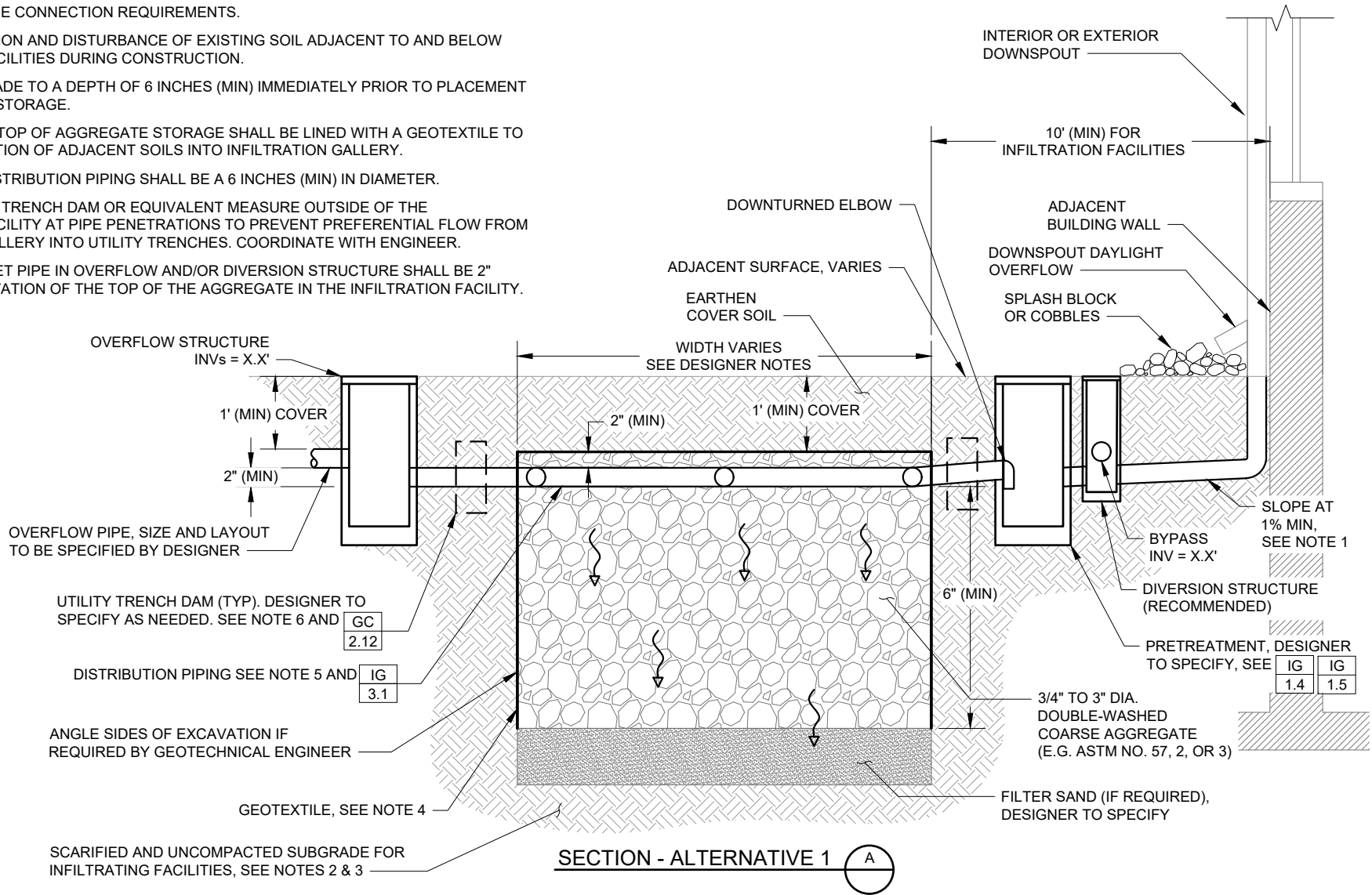

NOT FOR CONSTRUCTION - REFER TO USER GUIDE

NOTES			PRE-TREATMENT		LARGE SYSTEMS		MEDIUM SYSTEMS		SMALL SYSTEMS	
IG	IG	IG	IG	IG	IG	IG	IG	IG	IG	IG
1.1	1.2	1.3	1.4	1.5	2.1	2.2	3.1	3.2	4.1	4.2



**GREEN INFRASTRUCTURE
TYPICAL DETAILS**
SAN FRANCISCO PUBLIC UTILITIES COMMISSION

DATE	JANUARY 2023
VERSION	3.0
REVISED	

INFILTRATION GALLERIES
MEDIUM SYSTEMS - SECTION

DWG NO.
**IG
3.2**

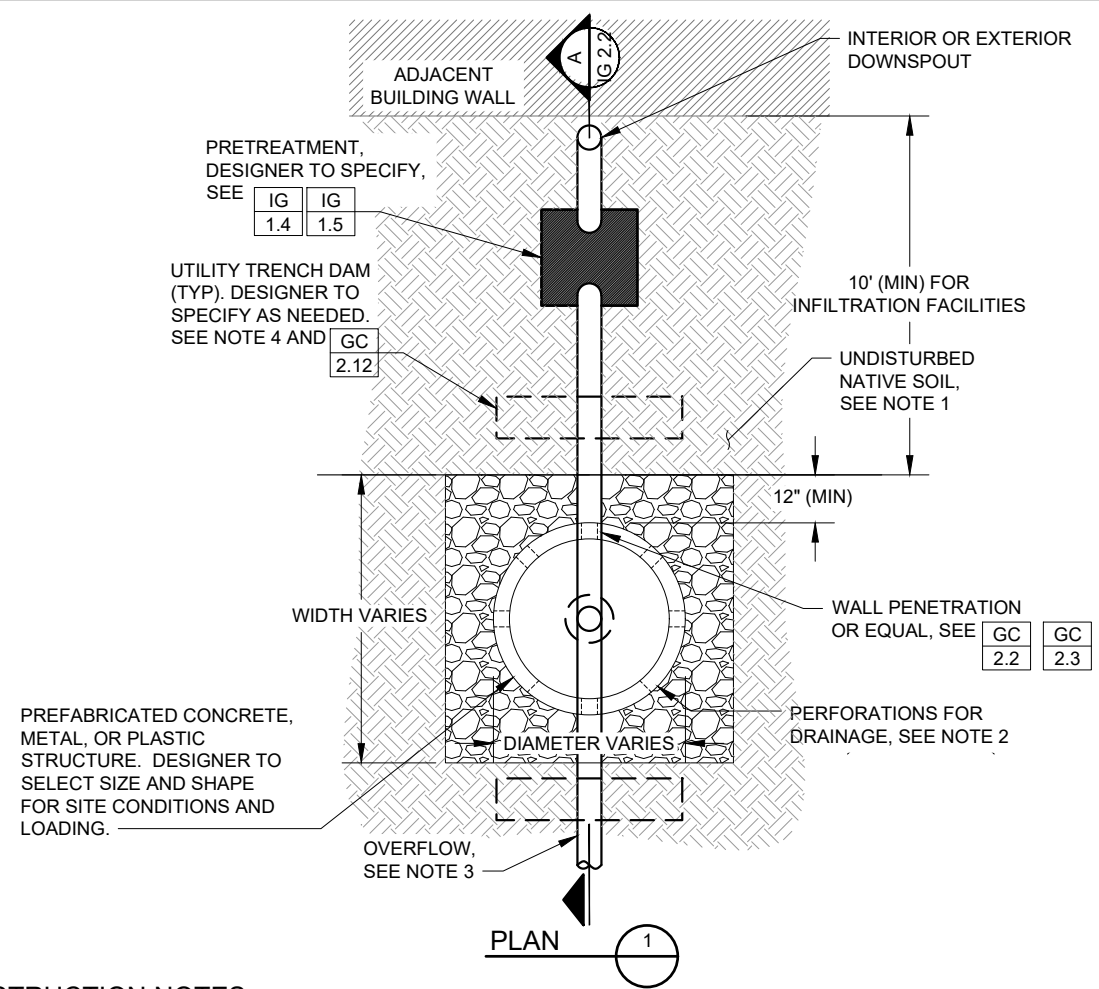

CONSTRUCTION NOTES:

1. AVOID COMPACTION AND DISTURBANCE OF EXISTING SOIL WITHIN 5 FEET ADJACENT TO AND BELOW INFILTRATION FACILITIES DURING CONSTRUCTION.
2. PREFABRICATED DRY WELLS SHALL HAVE SMALL DIAMETER PERFORATIONS TO PREVENT LATERAL MOVEMENT OF AGGREGATE INTO WELL AND SHALL BE SUFFICIENT IN NUMBER TO ALLOW FOR THE DRAINAGE OF THE STRUCTURE WITHIN 48 HOURS.
3. ROUTE OVERFLOW PIPE TO THE STORM SEWER OR TO ANOTHER BMP FOR FURTHER TREATMENT AS SHOWN ON THE DESIGN PLANS.
4. PROVIDE UTILITY TRENCH DAM OR EQUIVALENT MEASURE OUTSIDE OF THE INFILTRATION FACILITY AT PIPE PENETRATIONS TO PREVENT PREFERENTIAL FLOW FROM INFILTRATION GALLERY INTO UTILITY TRENCHES. COORDINATE WITH ENGINEER.

NOTES			PRE-TREATMENT		LARGE SYSTEMS		MEDIUM SYSTEMS		SMALL SYSTEMS	
IG	IG	IG	IG	IG	IG	IG	IG	IG	IG	IG
1.1	1.2	1.3	1.4	1.5	2.1	2.2	3.1	3.2	4.1	4.2



**GREEN INFRASTRUCTURE
TYPICAL DETAILS**
SAN FRANCISCO PUBLIC UTILITIES COMMISSION

DATE	JANUARY 2023
VERSION	3.0
REVISED	

INFILTRATION GALLERIES
SMALL SYSTEMS - PLAN

DWG NO.
**IG
4.1**

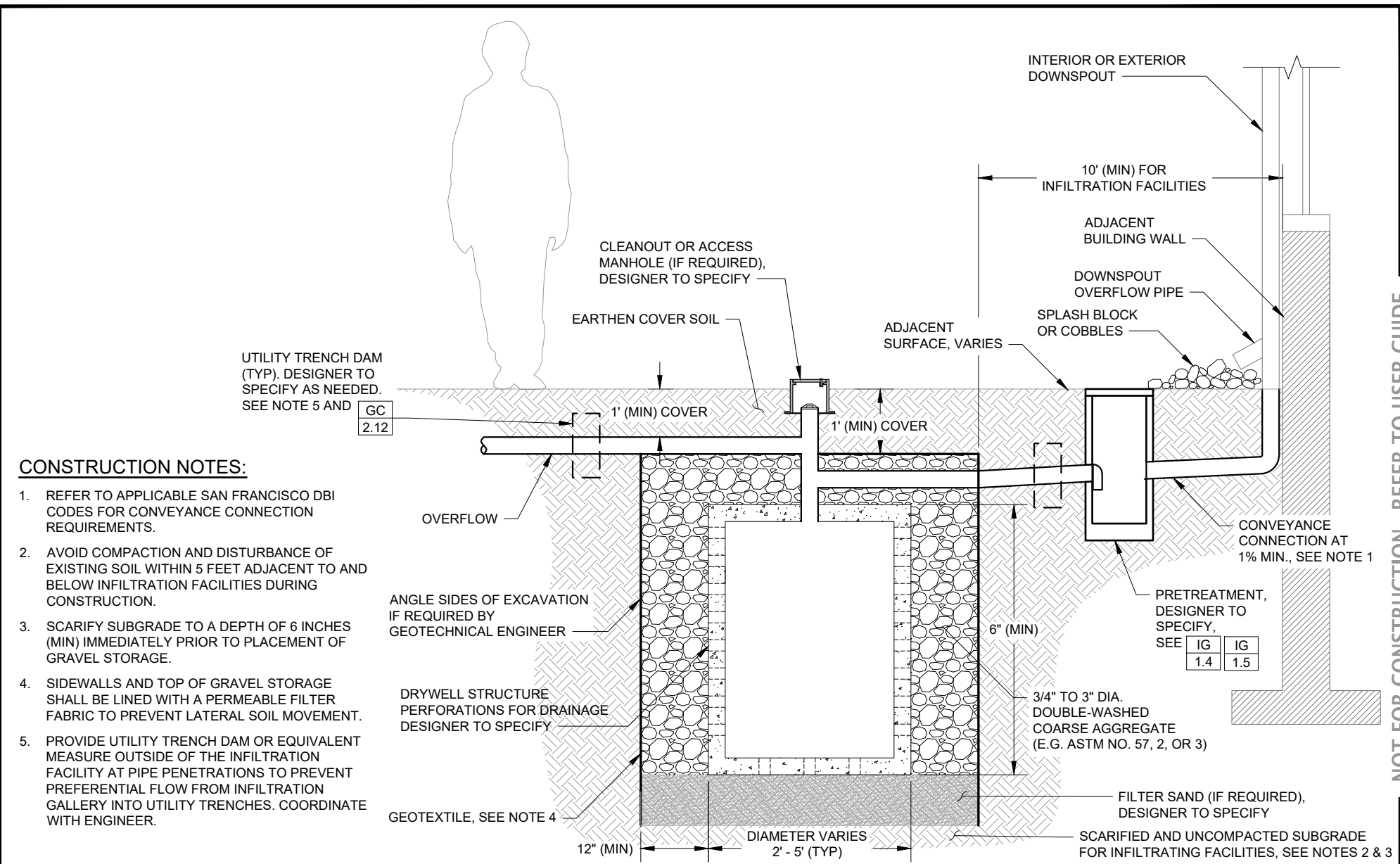

CONSTRUCTION NOTES:

1. REFER TO APPLICABLE SAN FRANCISCO DBI CODES FOR CONVEYANCE CONNECTION REQUIREMENTS.
2. AVOID COMPACTION AND DISTURBANCE OF EXISTING SOIL WITHIN 5 FEET ADJACENT TO AND BELOW INFILTRATION FACILITIES DURING CONSTRUCTION.
3. SCARIFY SUBGRADE TO A DEPTH OF 6 INCHES (MIN) IMMEDIATELY PRIOR TO PLACEMENT OF GRAVEL STORAGE.
4. SIDEWALLS AND TOP OF GRAVEL STORAGE SHALL BE LINED WITH A PERMEABLE FILTER FABRIC TO PREVENT LATERAL SOIL MOVEMENT.
5. PROVIDE UTILITY TRENCH DAM OR EQUIVALENT MEASURE OUTSIDE OF THE INFILTRATION FACILITY AT PIPE PENETRATIONS TO PREVENT PREFERENTIAL FLOW FROM INFILTRATION GALLERY INTO UTILITY TRENCHES. COORDINATE WITH ENGINEER.

GC
2.12

SEE
IG 1.4 IG 1.5

SECTION - ALTERNATIVE 1 (A)

NOTES			PRE-TREATMENT		LARGE SYSTEMS		MEDIUM SYSTEMS		SMALL SYSTEMS	
IG	IG	IG	IG	IG	PLAN SECTIONS	PLAN SECTIONS	PLAN SECTIONS	PLAN SECTIONS	PLAN SECTIONS	PLAN SECTIONS
1.1	1.2	1.3	1.4	1.5	2.1	2.2	3.1	3.2	4.1	4.2

NOT FOR CONSTRUCTION - REFER TO USER GUIDE



**GREEN INFRASTRUCTURE
TYPICAL DETAILS**
SAN FRANCISCO PUBLIC UTILITIES COMMISSION

DATE	JANUARY 2023
VERSION	3.0
REVISED	

INFILTRATION GALLERIES
SMALL SYSTEMS - SECTION

DWG NO.
**IG
4.2**

PURPOSE:

VEGETATED ROOFS (ALSO CALLED LIVING ROOFS, GREEN ROOFS, ECO-ROOFS, ROOF GARDENS, AND PLANTERS ON STRUCTURE) CONTROL PEAK FLOWS AND VOLUMES OF STORMWATER RUNOFF VIA STORAGE IN THE GROWING MEDIA AND EVAPOTRANSPIRATION FROM THE PLANTS IN VEGETATED SURFACES ON ROOFTOPS AND DECKS. VEGETATED ROOFS ARE ALLOWED AS STORMWATER CONTROLS IN THE COMBINED SEWER SYSTEM (CSS) AREA AND THE MUNICIPAL SEPARATE STORM SEWER SYSTEM (MS4) AREA PER THE MS4 PERMIT.

DESCRIPTION:

VEGETATED ROOFS ARE GENERALLY CLASSIFIED AS **EXTENSIVE, SEMI-INTENSIVE, OR INTENSIVE SYSTEMS** (AKA. TRADITIONAL PLANTER ON STRUCTURE) BASED ON VARIOUS CRITERIA SUCH AS DEPTH AND SATURATED WEIGHT OF THE GROWING MEDIA. EXTENSIVE AND SEMI-INTENSIVE VEGETATED ROOFS ARE TYPICALLY SHALLOWER SYSTEMS WITH LIGHTWEIGHT GROWING MEDIA, WHILE INTENSIVE VEGETATED ROOFS ARE TYPICALLY DEEPER SYSTEMS THAT USE HEAVIER WEIGHT GROWING MEDIA; SEE **VR 2.1** and **VR 2.2** FOR TYPICAL VEGETATED ROOF SECTIONS PER CLASSIFICATION.

DESIGNER NOTES & GUIDELINES:

1. **GREEN ROOF PROFESSIONAL (GRP) ACCREDITATION** IS RECOMMENDED FOR DESIGNERS OF EXTENSIVE AND SEMI-INTENSIVE VEGETATED ROOFS.
2. THE VEGETATED ROOF DESIGNER MUST PROVIDE CUSTOMIZED PLAN AND SECTION DRAWINGS TO SPECIFY THE SYSTEM TYPE AND BUILDING-SPECIFIC CONDITIONS.
3. THE MINIMUM REQUIRED DEPTH OF GROWING MEDIA FOR AN EXTENSIVE VEGETATED ROOF IS 5 TO 6 INCHES. SFPUC ALLOWS A MINIMUM EXTENSIVE VEGETATED ROOF GROWING MEDIA DEPTH OF 4 INCHES WHEN LOCATED ON WOOD FRAME STRUCTURES, IF LOADING IS A CONCERN.
4. **EXTENSIVE** AND **SEMI-INTENSIVE** VEGETATED ROOFS ARE ALLOWED TO SPECIFY A LIGHTWEIGHT GROWING MEDIA (< 80 LB/CF) AND TYPICALLY HAVE A DEPTH RANGING FROM 6 TO 18 INCHES.
5. **INTENSIVE VEGETATED ROOFS** MUST SPECIFY A GROWING MEDIA WITH A SATURATED WEIGHT ≥ 80 LBS/CF AND MUST HAVE A MINIMUM OF 12 INCHES OF SOIL; PLANTERS WITH LESS THAN 12 INCHES OF SOIL SHOULD BE DESIGNED AS A EXTENSIVE / SEMI-INTENSIVE VEGETATED ROOF.
6. INTENSIVE VEGETATED ROOFS MUST USE THE FOLLOWING CURVE NUMBERS (**CNs**) IN THE SFPUC CALCULATOR BASED ON THE GROWING MEDIA DEPTH (OR WEIGHTED AVERAGE):
 - SHALLOW: 12 TO 17.5 INCHES, USE CN=80
 - STANDARD: 18 TO 29.5 INCHES, USE CN=77
 - DEEP: ≥ 30 INCHES, USE CN=74
 - NOTE: INTENSIVE VEGETATED ROOFS WITH TWO AVERAGE DEPTH CATEGORIES CAN BE ENTERED IN THE SFPUC CALCULATOR BY USING THE "OTHER" LINE FOR THE SECOND DEPTH AND ENTERING THE APPROPRIATE CURVE NUMBER.
7. THE USE OF MULCH IS SUPPORTED AND HAS VARIOUS BENEFITS, BUT IS NOT REQUIRED BY SFPUC.
8. THE VEGETATION COVERAGE OF SELECTED PLANTS AND GROUNDCOVERS SHALL BE SPECIFIED TO ACHIEVE HIGH DENSITY COVERAGE (E.G., MORE THAN 75%) WITHIN 2 YEARS.
9. RUN-ON IS ONLY ALLOWED FROM MINOR/NEGLIGIBLE ADJACENT SURFACES SUCH AS MECHANICAL EQUIPMENT, ACCESS PATHS, OR SKYLIGHTS. RUN-ON FROM SOLAR PANELS IS REVIEWED AND APPROVED ON A CASE-BY-CASE BASIS.
10. UNLESS DESIGNED FOR FOOT TRAFFIC, VEGETATED ROOF AREAS THAT ARE ACCESSIBLE TO THE PUBLIC SHALL BE PROTECTED (E.G., SIGNS, RAILING, FENCING) FROM FOOT TRAFFIC AND OTHER LOADS.

NOTES		DETAILS	
VR 1.1	VR 1.2	VR 2.1	VR 2.2



**GREEN INFRASTRUCTURE
TYPICAL DETAILS**
SAN FRANCISCO PUBLIC UTILITIES COMMISSION

DATE	JANUARY 2023
VERSION	3.0
REVISED	

**VEGETATED ROOF
DESIGNER NOTES (1 OF 2)**

DWG. NO.
**VR
1.1**

NOT FOR CONSTRUCTION - REFER TO USER GUIDE

LAYOUT REQUIREMENTS:

1. DESIGNER MUST COMPLY WITH ALL CURRENT LOCAL CODES, INCLUDING BUT NOT LIMITED TO:
 - SAN FRANCISCO STORMWATER MANAGEMENT ORDINANCE
 - SAN FRANCISCO PLANNING CODE
 - CALIFORNIA BUILDING CODE
 - CALIFORNIA FIRE CODE
 - CALIFORNIA PLUMBING CODE
 - SAN FRANCISCO BUILDING CODE AMENDMENTS
 - ADA STANDARDS FOR ACCESSIBLE DESIGN
2. REFER TO THE 'SAN FRANCISCO LIVING ROOF MANUAL' FOR GENERAL (I.E., NON-STORMWATER COMPLIANCE RELATED) VEGETATED ROOF DESIGN REQUIREMENTS AND GUIDANCE.
3. REFER TO THE MOST CURRENT 'GREEN ROOF DESIGN AND INSTALLATION – RESOURCE MANUAL' FOR DETAILED DESIGN GUIDANCE (PUBLISHED BY GREEN ROOFS FOR HEALTHY CITIES).
4. DESIGN ALL VEGETATED ROOFS TO BE ACCESSIBLE FOR INSPECTIONS AND MAINTENANCE WITHOUT ACCESS THROUGH A TENANT RESIDENTIAL UNIT WHERE FEASIBLE.
5. INCORPORATE 'SAFETY BY DESIGN' INTO ALL ROOFTOP VEGETATED SYSTEMS TO ENSURE EASE OF ACCESS FOR MAINTENANCE AND INSPECTION. ADHERE TO APPLICABLE CAL-OSHA AND BUILDING CODES.
6. VEGETATED ROOF LAYOUT PLANS SHALL CONSIDER ACCESS REQUIREMENTS AND AVOID CONFLICTS AT TRANSITIONS BETWEEN VEGETATED ROOF AND ROOFTOP MECHANICAL EQUIPMENT, DOORS, FANS, SKYLIGHTS, AND OTHER ROOF PENETRATIONS.

DESIGNER CHECKLIST (MUST SPECIFY AS APPLICABLE):

- DEPTH OF GROWING MEDIA (OR WEIGHTED AVERAGE)
- GROWING MEDIA SPECIFICATION (INCLUDING SATURATED WEIGHT)
- DETAILS AND DIMENSIONS FOR TRAY SYSTEM, EDGES, AND TRANSITIONS
- VEGETATED ROOF PLANTING PLAN (EXTENTS, SPECIES, AND SPACING)
- VEGETATED ROOF GROWING MEDIA SURFACE ELEVATION, AS NEEDED (RAIN LEADER PENETRATION COORDINATION)
- ROOF SLOPE AND DIRECTION
- IRRIGATION SYSTEM (IF COMPONENT OF RAINWATER HARVESTING SYSTEM)

THE FOLLOWING STANDARD DESIGN INFORMATION SHOULD ALSO BE INCLUDED, BUT WILL NOT BE REVIEWED BY SFPUC:

- DEPTH AND TYPE OF DRAINAGE LAYERS
- MULCH LAYER (IF INCLUDED)
- TYPE AND EXTENTS OF WATERPROOF MEMBRANE, ROOT BARRIER, AND FILTER FABRIC (IF INCLUDED)
- TYPE AND EXTENTS OF LEAK DETECTION SYSTEM (IF INCLUDED)
- DOCUMENTATION OF LOAD-BEARING CAPACITY FOR COMPLIANCE WITH BUILDING CODE REQUIREMENTS
- DOCUMENTATION OF HYDRAULIC CAPACITY FOR PRIMARY AND SECONDARY ROOF DRAINS
- DIMENSIONS AND DISTANCE TO PRIMARY AND SECONDARY ROOF DRAINS AND VEGETATED ROOF COMPONENTS
- ELEVATIONS OF PRIMARY AND SECONDARY ROOF DRAINS
- IRRIGATION SYSTEM (NO RAINWATER HARVESTING)

NOTES		DETAILS	
VR	VR	VR	VR
1.1	1.2	2.1	2.2



**GREEN INFRASTRUCTURE
TYPICAL DETAILS**
SAN FRANCISCO PUBLIC UTILITIES COMMISSION

DATE	JANUARY 2023
VERSION	3.0
REVISED	

**VEGETATED ROOF
DESIGNER NOTES (2 OF 2)**

DWG NO.
**VR
1.2**

CONSTRUCTION NOTES (TO BE CUSTOMIZED BY DESIGNER):

1. FOR EXTENSIVE AND SEMI-INTENSIVE VEGETATED ROOF INSTALLATIONS, THE CONTRACTOR IS RECOMMENDED TO BE A "CERTIFIED GREEN ROOFER", AS REQUIRED BY THE MANUFACTURER OR LANDSCAPE ARCHITECT. CONTRACTOR SHALL MAINTAIN AN EXPERIENCED, VEGETATED ROOF SUPERVISOR ON PROJECT SITE WHEN WORK IS IN PROGRESS.
2. FOLLOW MANUFACTURER'S SPECIFICATIONS AND DRAWINGS IN ALL CASES WHERE THE MANUFACTURER'S CONTRACT FURNISHES DIRECTIONS NOT SPECIFIED OR SHOWN IN THE DRAWINGS.
3. PROTECT BUILDING INFRASTRUCTURE AND WATERPROOFING FROM DAMAGE.
4. CONDUCT A LEAK TEST ON THE WATERPROOF MEMBRANE PRIOR TO INSTALLING ADDITIONAL VEGETATED ROOF LAYERS, AS REQUIRED BY THE MANUFACTURER OR LANDSCAPE ARCHITECT.
5. ALL OTHER WORK IN AND DIRECTLY ADJACENT TO THE VEGETATED ROOF AREAS MUST BE COMPLETED BEFORE INSTALLATION BEGINS.
6. INSTALLATION SHALL BE PERFORMED IN ACCORDANCE WITH APPLICABLE CODE REQUIREMENTS.
7. REPORT DISCREPANCIES IN DRAWINGS OR SPECIFICATIONS TO THE MANUFACTURER OR LANDSCAPE ARCHITECT FOR CLARIFICATION AND ADJUSTMENT BEFORE COMMENCING WORK. CHANGES IN THESE DRAWINGS REQUIRE WRITTEN ACCEPTANCE FROM THE MANUFACTURER OR LANDSCAPE ARCHITECT.

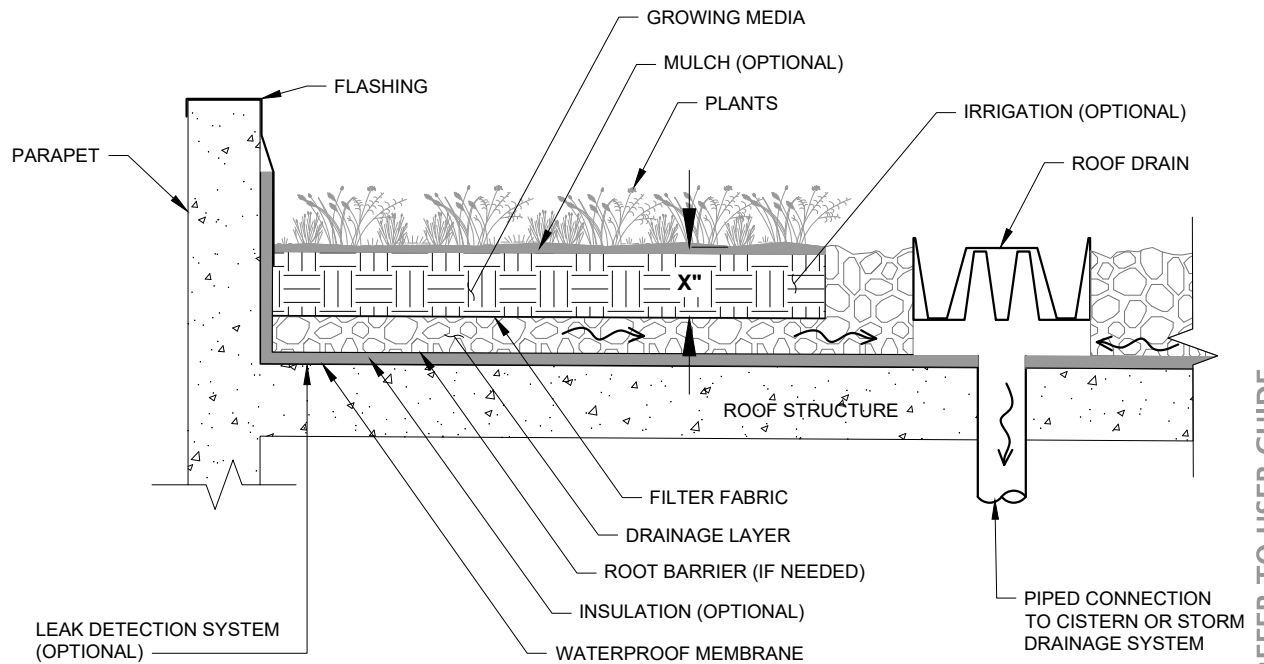

EXTENSIVE AND SEMI-INTENSIVE VEGETATED ROOF (1)
 (ILLUSTRATIVE ONLY- DESIGNER TO CUSTOMIZE)

SMO REQUIRED CRITERIA:

CRITERIA	EXTENSIVE AND SEMI-INTENSIVE
GROWING MEDIA SATURATED DEPTH	LIGHTWEIGHT MEDIA (< 80 LB/CF)
GROWING MEDIA DEPTH	5 - 18" *
* THE MINIMUM DEPTH OF GROWING MEDIA IS 5 INCHES EXCEPT ON WOOD FRAME STRUCTURES, WHERE SFPUC ALLOWS A MINIMUM DEPTH OF 4 INCHES.	

TYPICAL APPLICATIONS:

COMPONENT	EXTENSIVE AND SEMI-INTENSIVE
VEGETATION	LOWER DIVERSITY OF PLANTS: MAINLY SUCCULENTS WITH OTHER GROUNDCOVERS, WITH PERENNIALS AT GREATER GROWING MEDIA DEPTHS
CONTAINMENT SYSTEM	PROPRIETARY TRAY SYSTEM, OR CUSTOM DESIGNED, ETC.

NOTES		DETAILS	
VR	VR	VR	VR
1.1	1.2	2.1	2.2

NOT FOR CONSTRUCTION - REFER TO USER GUIDE



**GREEN INFRASTRUCTURE
 TYPICAL DETAILS**
 SAN FRANCISCO PUBLIC UTILITIES COMMISSION

DATE	JANUARY 2023
VERSION	3.0
REVISED	

**VEGETATED ROOF
 EXTENSIVE AND SEMI-INTENSIVE**

DWG NO.
**VR
 2.1**

CONSTRUCTION NOTES (TO BE CUSTOMIZED BY DESIGNER):

1. FOLLOW MANUFACTURER'S SPECIFICATIONS AND DRAWINGS IN ALL CASES WHERE THE MANUFACTURER'S CONTRACT FURNISHES DIRECTIONS NOT SPECIFIED OR SHOWN IN THE DRAWINGS.
2. PROTECT BUILDING INFRASTRUCTURE AND WATERPROOFING FROM DAMAGE.
3. INSTALLATION SHALL BE PERFORMED IN ACCORDANCE WITH APPLICABLE CODE REQUIREMENTS.
4. REPORT DISCREPANCIES IN DRAWINGS OR SPECIFICATIONS TO THE MANUFACTURER OR LANDSCAPE ARCHITECT FOR CLARIFICATION AND ADJUSTMENT BEFORE COMMENCING WORK. CHANGES IN THESE DRAWINGS REQUIRE WRITTEN ACCEPTANCE FROM THE MANUFACTURER OR LANDSCAPE ARCHITECT.

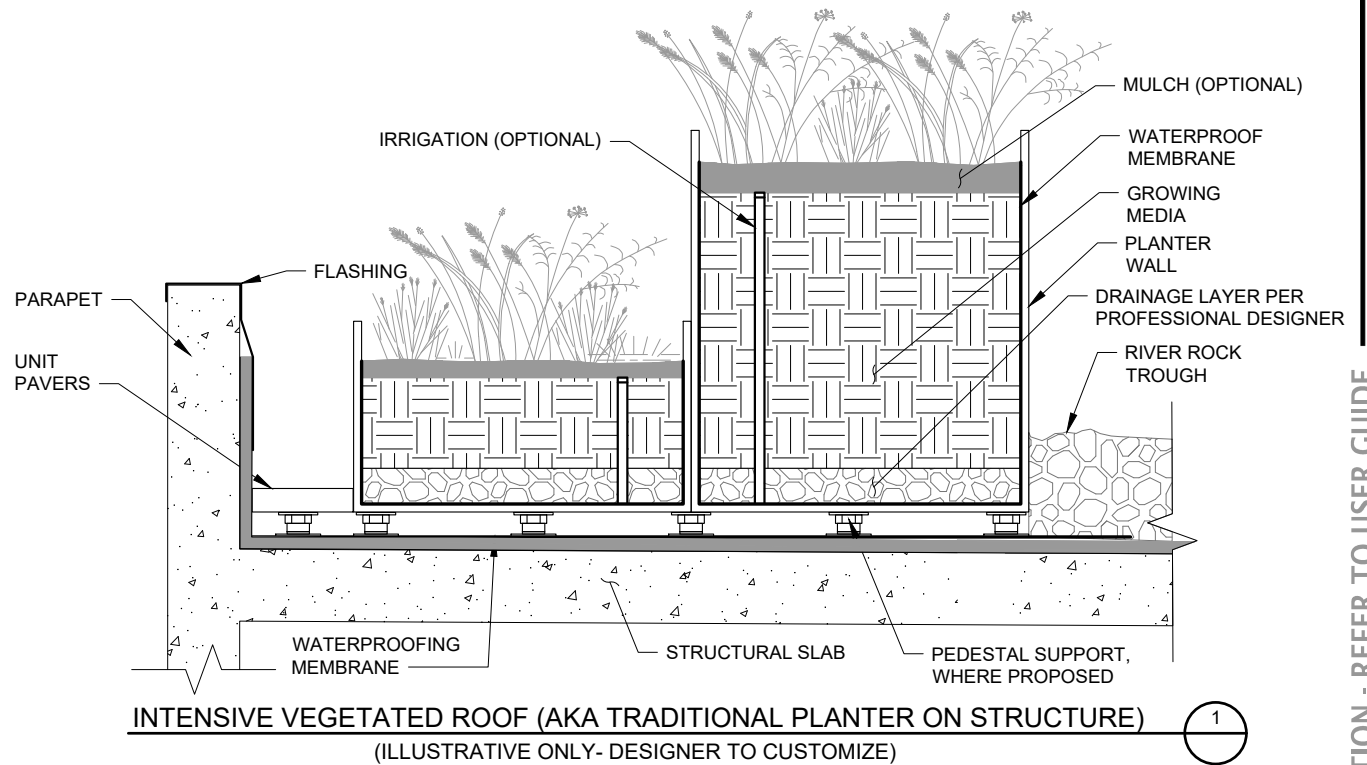

SMO REQUIRED CRITERIA:

CRITERIA	INTENSIVE
GROWING MEDIA SATURATED DEPTH	STANDARD MEDIA (≥ 80 LB/CF)
GROWING MEDIA DEPTH	≥ 12"

TYPICAL APPLICATIONS:

COMPONENT	INTENSIVE
VEGETATION	HIGH DIVERSITY OF PLANTS, INCLUDING: GRASSES, SHRUBS, AND TREES
CONTAINMENT SYSTEM	MANUFACTURED PLANTER BOXES, OR ON-DECK PLANTER, ETC.

NOTES		DETAILS	
VR 1.1	VR 1.2	VR 2.1	VR 2.2



**GREEN INFRASTRUCTURE
TYPICAL DETAILS**
SAN FRANCISCO PUBLIC UTILITIES COMMISSION

DATE	JANUARY 2023
VERSION	3.0
REVISED	

**VEGETATED ROOF
INTENSIVE**

DWG NO.
**VR
2.2**

NOT FOR CONSTRUCTION - REFER TO USER GUIDE

PURPOSE:

IMPERMEABLE LINERS IN GREEN INFRASTRUCTURE CAN BE USED TO RESTRICT MOVEMENT OF WATER INTO UNDERLYING AND/OR ADJACENT SOILS AND/OR AGGREGATES TO PROTECT SENSITIVE INFRASTRUCTURE (E.G., IMPERMEABLE ROADWAY BASE, FOUNDATIONS, UTILITIES), MITIGATE RISK OF GEOLOGIC HAZARDS (E.G., STEEP SLOPES, CONTAMINATED SOILS), OR OTHER SITE-SPECIFIC CONDITIONS)

DESIGNER NOTES & GUIDELINES:

1. THE DESIGNER MUST ADAPT DRAWINGS TO ADDRESS SITE-SPECIFIC CONDITIONS.
2. THE DESIGNER AND/OR GEOTECHNICAL ENGINEER SHOULD ASSESS THE RISK OF WATER LEAKAGE FROM THE PLANTER AND DETERMINE THE LINER EXTENTS AND LINER CONNECTION REQUIREMENTS (E.G., WATER TIGHT, SOIL TIGHT), DEPENDING ON DEGREE OF PROTECTION NECESSARY TO PROTECT ADJACENT INFRASTRUCTURE.
6. CONSIDER PLACING GEOTEXTILE ON PREPARED SUBGRADE PRIOR TO PLACEMENT OF LINER TO PROTECT LINER FROM DAMAGE DURING INSTALLATION.
7. DEPENDING ON ANTICIPATED FACILITY MAINTENANCE, IT MAY BE PRUDENT TO INCLUDE A GEOTEXTILE OVER THE LINER TO PROVIDE AN ADDITIONAL BARRIER BETWEEN LINER AND MAINTENANCE EQUIPMENT OR TO PROTECT AGAINST AGGRESSIVE PUNCTURES DURING PLACEMENT AND COMPACTION.

DESIGNER CHECKLIST (MUST SPECIFY, AS APPLICABLE):

- LINER TYPE AND EXTENTS (E.G., FULL LINER, PARTIAL LINER)
- LINER ANCHOR TYPE (E.G., WATER TIGHT, SOIL TIGHT)
- LINER JOINT WELDING/SEALING REQUIREMENTS
- OTHER CRITICAL PROJECT-SPECIFIC PLACEMENT REQUIREMENTS

NOT FOR CONSTRUCTION - REFER TO USER GUIDE

NOTES COMPONENTS

GC	GC
1.1	1.2



**GREEN INFRASTRUCTURE
TYPICAL DETAILS**
SAN FRANCISCO PUBLIC UTILITIES COMMISSION

DATE	JANUARY 2023
VERSION	3.0
REVISED	

**GENERAL COMPONENTS
LINERS
DESIGNER NOTES**

DWG NO.
**GC
1.1**

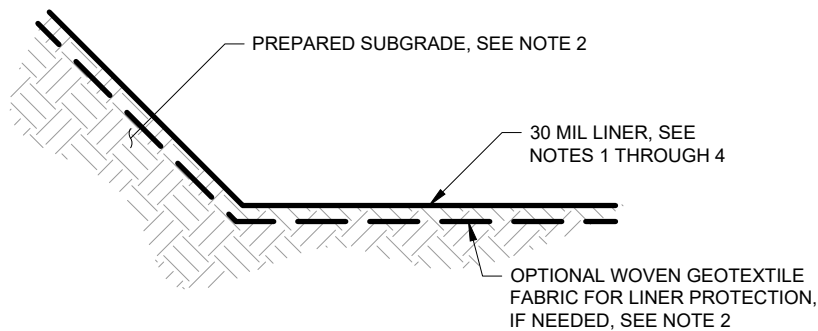

IMPERMEABLE LINER

1

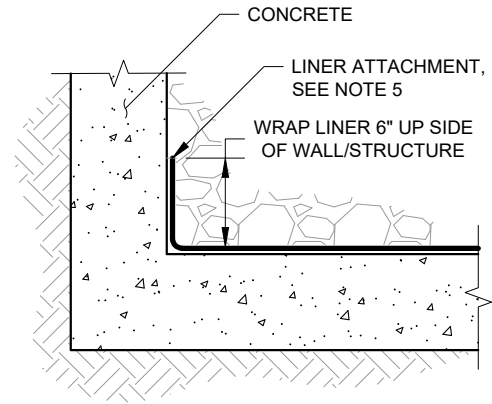

SOIL TIGHT LINER ATTACHMENT AT WALL/STRUCTURE

2

CONSTRUCTION NOTES:

1. WATERPROOFING AND/OR LINER SYSTEM TO BE DESIGNED AND INSTALLED BY WATERPROOFING PROFESSIONAL. POTENTIAL LINER MATERIALS TO BE CONSIDERED INCLUDE: HDPE (HIGH DENSITY POLYETHYLENE), CPSE (CHLOROSULFONATED POLYETHYLENE), OR LLDPE (LINEAR LOW DENSITY POLYETHYLENE).
2. LINER SHALL LAY FLUSH WITH GROUND WITH NO AIR VOIDS BELOW THE LINER PRIOR TO BACKFILLING MATERIAL ABOVE THE LINER AND REMOVE ALL SHARP ROCKS AND DEBRIS. IF SUBGRADE SOIL CONTAINS ANGULAR ROCKS/DEBRIS, INSTALL WOVEN GEOTEXTILE FABRIC OVER SUBGRADE TO PROTECT LINER FROM PUNCTURE. CONTOUR THE SUBGRADE AS NEEDED TO ENSURE LINER LAYS FLUSH WITH GROUND.
3. OVERLAP LINER PER MANUFACTURER'S RECOMMENDATIONS.
4. ALL SEAMS SHALL BE WELDED PER MANUFACTURER'S RECOMMENDATIONS UNLESS OTHERWISE SPECIFIED.
5. SECURE LINER CONTINUOUSLY WITH DOUBLE-SIDED TAPE ALONG LINER EDGE AND SINGLE SIDED TAPE ALONG THE TOP EDGE OF LINER TO HOLD LINER IN PLACE DURING BACKFILLING.
6. WHEN ADJACENT TO BUILDING WALL, LINER OR EQUAL WATERPROOFING SHALL EXTEND TO TOP OF FREEBOARD ELEVATION, OR PER WATERPROOFING PROFESSIONAL.
7. APPLY BATTEN STRIP, AND NEOPRENE RUBBER PAD CONTINUOUSLY ALONG TOP EDGE OF LINER. FOR WATER-TIGHT APPLICATIONS, ALSO APPLY BUTYL MASTIC CAULK.
8. FOR WATER-TIGHT APPLICATIONS, APPLY BEAD OF POLYURETHANE ELASTOMERIC SEALANT CONTINUOUSLY ALONG TOP EDGE OF BATTEN STRIP ASSEMBLY.

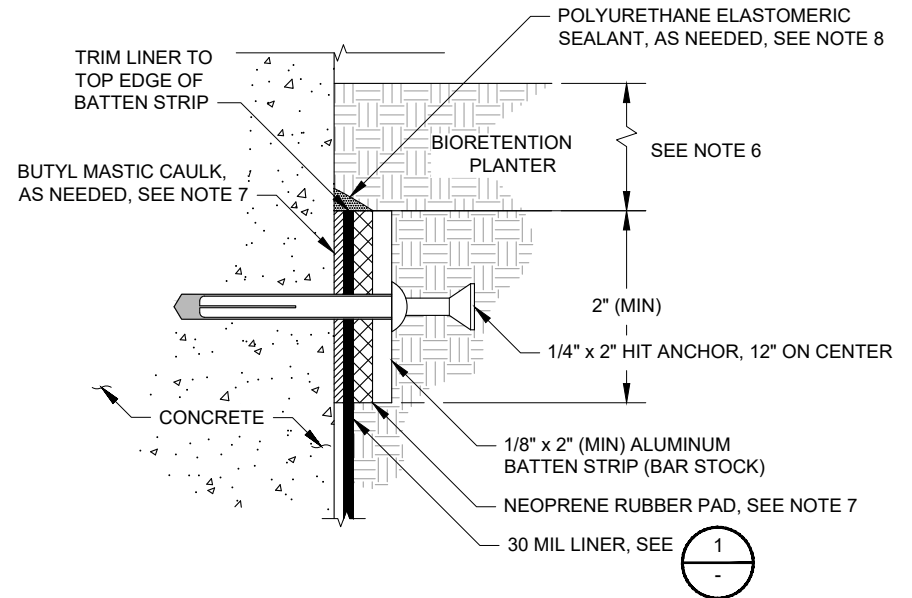

LINER ATTACHMENT AT WALL/STRUCTURE

3

NOTES		COMPONENTS	
GC	1.1	GC	1.2



**GREEN INFRASTRUCTURE
TYPICAL DETAILS**

SAN FRANCISCO PUBLIC UTILITIES COMMISSION

DATE	JANUARY 2023
VERSION	3.0
REVISED	

**GENERAL COMPONENTS
LINERS
LINERS AND ATTACHMENTS**

DWG NO.	GC 1.2
---------	------------------

NOT FOR CONSTRUCTION - REFER TO USER GUIDE

PURPOSE:

WHEN SITING GREEN INFRASTRUCTURE (GI) FACILITIES, THE DESIGNER SHOULD LOCATE AND ASSESS ALL KNOWN UTILITY CROSSINGS AND CONFLICTS AND ADJUST THE DESIGN TO AVOID AS MANY EXISTING UTILITIES AS POSSIBLE. THE CRITICALITY OF UTILITY CONFLICTS IN TERMS OF THEIR POTENTIAL IMPACT TO THE PROJECT'S DESIGN PERFORMANCE, COST, AND SCHEDULE SHOULD BE CAREFULLY EVALUATED DURING THE PLANNING PHASE.

THE PURPOSE OF THE FOLLOWING TYPICAL UTILITY CROSSING DETAILS IS TO ALERT THE DESIGNERS TO COMMON UTILITY CROSSINGS THAT OCCUR ON GI PROJECTS WITHIN THE PUBLIC RIGHT-OF-WAY AND PROVIDE GENERAL GUIDANCE ON THE PROTECTION OF THESE UTILITIES. THEY ARE PROVIDED AS TYPICAL APPLICATIONS AND DO NOT REPRESENT APPROVED CITY UTILITY STANDARDS AND SPECIFICATIONS. IN ADDITION TO THESE TYPICAL DETAILS, DESIGNERS MUST FOLLOW ALL APPLICABLE LOCAL AND FEDERAL REGULATIONS ASSOCIATED WITH THEIR PROJECT.

DESIGNER NOTES & GUIDELINES:

1. THE DESIGNER MUST ADAPT DRAWINGS TO ADDRESS SITE-SPECIFIC CONDITIONS AND UTILITY REQUIREMENTS AND OBTAIN APPROVAL FROM ALL RELEVANT UTILITY PROVIDERS PRIOR TO CONSTRUCTION. COORDINATION AND APPROVAL FROM THE FOLLOWING UTILITY PROVIDERS MAY BE NECESSARY, BUT NOT EXCLUSIVELY:
 - SFPUC CITY DISTRIBUTION DIVISION (CDD) FOR DOMESTIC/RECYCLED/FIRE WATER
 - SFPUC WASTEWATER ENTERPRISE (WWE) FOR SANITARY/STORM/SEWER
 - PACIFIC GAS ELECTRIC (PGE) FOR ELECTRIC/GAS/UTILITY POLES
 - SFMTA FOR TRAFFIC SIGNAL/STREET SIGNS/PARKING METERS/BUS STOPS AND CATENARY POLES.
2. NEW UTILITY LINES AND SERVICES SHALL BE LOCATED AND ROUTED TO AVOID STORMWATER FACILITIES.
3. MINIMUM UTILITY SETBACKS AND PROTECTION MEASURES MUST CONFORM TO CURRENT SFPUC ASSET PROTECTION STANDARDS. NOTE WHICH UTILITY APPURTENANCES (I.E. CLEANOUT VENTS, WATER METER BOXES, HYDRANTS, VALVES, ETC.) ARE NOT ALLOWED WITHIN BIORETENTION PLANTERS. REFER TO THE SFPUC SEWER LATERAL DETAILS FOR THE PLACEMENT OF CLEANOUT VENTS WITHIN BIORETENTION PLANTERS. PER CURRENT STANDARDS, POTABLE WATER DISTRIBUTION MAINS ARE NOT PERMITTED TO RUN UNDER OR THROUGH BIORETENTION PLANTERS.
4. UTILITY CONFLICTS SHALL BE MITIGATED PER SFPUC SURFACE IMPROVEMENT STANDARDS AND OTHER UTILITY PROVIDER REQUIREMENTS. ENGINEER TO EVALUATE CONDITIONS AND NEED TO INCLUDE MEASURES TO ENSURE WATER TIGHT UTILITY PENETRATIONS THROUGH PLANTER WALL, AS NEEDED AND TO PREVENT PREFERENTIAL FLOW INTO UTILITY TRENCHES (E.G., WATER STOP, TRENCH BLOCK, OR TRENCH COLLAR). (REFER TO GC 2.9 - 2.12)

5. THE DESIGNER MUST DETERMINE THE TYPE OF PROTECTION MEASURE(S) REQUIRED BASED ON THE SITE-SPECIFIC CONDITIONS, UTILITY REQUIREMENTS, AND THE FUNCTION THE PROTECTION MEASURE MUST PERFORM. THE FOLLOWING ARE BRIEF DESCRIPTIONS OF THE PROTECTION MEASURES INCLUDED IN THESE DETAILS:
 - a. SOIL OR ENGINEERED FILL WITH OVERLYING IMPERMEABLE LINER: PROTECTS UTILITY FROM DAMAGE DURING FUTURE TRENCHING, EXCAVATION, AND LANDSCAPE ACTIVITIES. THE LINER PREVENTS PREFERENTIAL FLOW OF WATER INTO THE UTILITY TRENCH. THESE METHODS ARE GENERALLY ONLY ACCEPTABLE WHEN THE FACILITY DOES NOT INCLUDE AN UNDERDRAIN OR WHEN THE LINER CAN BE LOCATED BELOW THE INVERT OF THE UNDERDRAIN.
 - b. SLEEVE/CASING: BY HOUSING THE UTILITY PIPE WITHIN A LARGER CARRIER PIPE OR APPROVED SPLIT SLEEVE PRODUCT, THE UTILITY PIPE CAN BE REPLACED IF NEEDED IN THE FUTURE WITHOUT SIGNIFICANT IMPACT TO THE OVERLYING INFRASTRUCTURE. THE SLEEVE ALSO PROTECTS THE PIPE FROM IMPACT DURING CONSTRUCTION AND FUTURE TRENCHING, EXCAVATION, AND LANDSCAPE ACTIVITIES. ADDITIONALLY, SLEEVES CAN BE USED TO SEAL THE UTILITY FROM THE INFILTRATED STORMWATER AND/OR PROTECT THE INFILTRATION FACILITY FROM SEWER LATERAL LEAKAGES. SEE THE UTILITY SLEEVE GUIDANCE.
 - c. UTILITY TRENCH DAM: WHERE UTILITY TRENCHES CROSS UNDER INFILTRATIVE FACILITIES, SUBSURFACE WATER MAY PREFERENTIALLY FLOW THROUGH THE TRENCH AND CAUSE DAMAGE TO DOWNSTREAM INFRASTRUCTURE. RISKS INCLUDE BACKFILL EROSION, CREATION OF VOIDS, THE DEGRADATION OF OVERLYING FILL/PAVEMENT, AND SUBSURFACE WATER BEING DIRECTED TO BUILDING FOUNDATIONS OR BASEMENTS. UTILITY TRENCH DAMS PLACED OUTSIDE OF THE INFILTRATION FACILITY FOOTPRINT PREVENT WATER FROM TRAVELING FURTHER ALONG THE UTILITY TRENCH.
 - d. INSULATING WRAP: PROVIDES IMPACT AND WATER PROTECTION FOR EXISTING SHALLOW UTILITY SERVICE LINES THAT ARE REMAINING IN PLACE WITHIN INFILTRATION FACILITIES.
6. FOR PERMEABLE PAVEMENT FACILITIES, UTILITY CROSSINGS SHOULD BE BELOW THE BOTTOM OF THE STRUCTURAL PAVEMENT SECTION, WHENEVER POSSIBLE. IF UTILITIES ENCROACH INTO THIS SECTION, THE ENGINEER SHALL CONFIRM THAT THE STRUCTURAL INTEGRITY OF THE PAVEMENT CAN BE MAINTAINED OVER THE UTILITY.
7. THE AREA OF SUBBASE COVERED BY SUBSURFACE CHECK DAMS, IMPERMEABLE LINERS, COMPACTED ENGINEERED FILL, CONCRETE PADS AND OTHER UTILITY INFRASTRUCTURE SHOULD BE EXCLUDED FROM HYDROLOGIC PERFORMANCE CALCULATIONS WHEN THE AREA IS SIGNIFICANT (GREATER THAN 10 PERCENT) RELATIVE TO THE INFILTRATIVE AREA.

NOT FOR CONSTRUCTION - REFER TO USER GUIDE

NOTES		BIORETENTION			PERMEABLE PAVEMENT			WALL PENETRATIONS			TRENCH DAM
GC 2.1	GC 2.2	GC 2.3	GC 2.4	GC 2.5	GC 2.6	GC 2.7	GC 2.8	GC 2.9	GC 2.10	GC 2.11	GC 2.12



**GREEN INFRASTRUCTURE
TYPICAL DETAILS**
SAN FRANCISCO PUBLIC UTILITIES COMMISSION

DATE	JANUARY 2023
VERSION	3.0
REVISED	

**GENERAL COMPONENTS
UTILITY CROSSINGS
DESIGNER NOTES (1 OF 2)**

DWG NO.
**GC
2.1**

UTILITY SLEEVE NOTES AND GUIDANCE:

THE DESIGNER MUST SPECIFY THE TYPE OF SLEEVE METHOD AND MATERIALS THAT SHALL BE USED FOR ALL APPLICABLE NEW AND EXISTING UTILITIES TO REMAIN IN PLACE WITHIN THE FOOTPRINT OF INFILTRATION FACILITIES. DEPENDING ON THE SPECIFIC SITE CONDITIONS AND GOVERNING UTILITY STANDARDS, EXISTING UTILITIES TO REMAIN IN PLACE SHALL BE SLEEVED THE ENTIRE LENGTH WITHIN THE INFILTRATION FACILITY USING ONE OF THE FOLLOWING METHODS OR AN APPROVED EQUAL:

- a. PLASTIC PIPE, 1 - 2 SIZES LARGER THAN UTILITY PIPE, CUT IN HALF, PLACED AROUND UTILITY PIPE, SEALED ALONG JOINTS WITH ADHESIVE, AND CLAMPED TOGETHER WITH STAINLESS STEEL BANDS/HOSE CLAMPS. PIPE SUPPORTS (E.G. CLOSED CELL FOAM BLOCKING) WITHIN THE SLEEVE PER UTILITY PROVIDER'S REQUIREMENTS.
- b. GEORGE FISCHER "CONTAIN-IT" PIPE CONTAINMENT SYSTEM PRODUCT, PART NO. 8326-040AA OR 8326-060AA OR EQUAL, INSTALLED PER MANUFACTURER'S RECOMMENDATIONS.
- c. STAINLESS STEEL SPLIT SLEEVE PRODUCT INSTALLED AROUND THE EXISTING PIPE AND POSITIONED IN THE FORM TO CENTER THE UTILITY PIPE. AFTER INSTALLATION, THE MANUFACTURER'S RECOMMENDED MATERIAL IS USED TO SEAL THE ANNULAR SPACE BETWEEN THE SPLIT SLEEVE AND PIPE. USE PIPE SEAL AND INSULATOR INC., WS SPLIT SEALWALL SLEEVE, OR EQUAL.

EXISTING UTILITY COORDINATION NOTES:

1. THE DESIGNER SHALL LOCATE ALL EXISTING UTILITIES WITHIN THE PROJECT AREA TO THE MOST PRACTICAL EXTENT POSSIBLE UTILIZING SITE SURVEYS, AS-BUILT PLANS, SITE INVESTIGATIONS, POTHOLING, UTILITY AGENCY DATA, ETC. AND PRESENT THIS INFORMATION AND SOURCE (I.E. AS-BUILT VS. ASSUMED LOCATION) CLEARLY ON THE DESIGN DRAWINGS. THE ASSUMED LOCATION OF EXISTING UTILITIES SHALL BE PROVIDED IN THE SAME COORDINATE SYSTEM AS THE REST OF THE DESIGN DRAWINGS. DESIGN DRAWINGS SHALL ALSO INCLUDE CONTACT INFORMATION FOR ANY UTILITIES AFFECTED BY THE PROJECT.
2. IF AN EXISTING UTILITY HAS THE POTENTIAL TO IMPACT THE PROJECT DESIGN AND/OR THE PERFORMANCE OF THE GI FACILITY, THE EXACT LOCATION, DEPTH, AND CONDITION OF THIS UTILITY SHOULD BE FIELD VERIFIED DURING THE DESIGN PHASE (VIA POTHOLING OR OTHER APPROVED METHOD) TO PREVENT COSTLY REDESIGNS AND/OR PROJECT DELAYS DURING CONSTRUCTION.
3. THE CONTRACTOR SHALL VERIFY THE LOCATIONS AND DEPTH OF EXISTING UTILITIES AT THE START OF CONSTRUCTION PER THE PROJECT SPECIFICATIONS. ANY DISCREPANCIES BETWEEN THE EXISTING UTILITIES SHOWN IN THE DESIGN DRAWINGS AND THE ACTUAL FIELD CONDITIONS SHOULD BE COMMUNICATED TO THE ENGINEER IMMEDIATELY.
4. THE CHECK DAM SPACING AND HEIGHT SPECIFIED ON THE DESIGN PLANS MUST BE MAINTAINED. IF THE CHECK DAM PROTECTING THE EXISTING UTILITY WILL IMPACT THE CHECK DAM SPACING SPECIFIED ON THE PLANS, THE ENGINEER MUST EVALUATE ITS IMPACT ON THE HYDROLOGIC PERFORMANCE AND APPROVE THE VARIANCE. SEE **PC 2.1** AND **PC 2.2** FOR FURTHER DETAILS.

DESIGNER CHECKLIST (MUST SPECIFY, AS APPLICABLE):

- LINER EMBEDMENT DEPTH INTO SUBGRADE SOILS
- PIPE AND SLEEVE MATERIALS AND DIAMETER FOR ALL WALL PENETRATIONS
- WALL PENETRATION TYPE (E.G., GROUTED, COMPRESSION, BOOT) SEE **GC 2.9 - 2.11**.
- GEOTEXTILE FABRICS AND/OR LINER MATERIALS
- ENGINEERED BACKFILL MATERIAL
- DIMENSIONS OF ALL PROTECTION MEASURES
- MINIMUM SETBACKS TO ADJACENT INFRASTRUCTURE, PAVEMENT BASES, SURFACES
- MINIMUM PIPE COVER AS REQUIRED BY UTILITY PROVIDER

NOTES		BIORETENTION			PERMEABLE PAVEMENT			WALL PENETRATIONS			TRENCH DAM
GC 2.1	GC 2.2	GC 2.3	GC 2.4	GC 2.5	GC 2.6	GC 2.7	GC 2.8	GC 2.9	GC 2.10	GC 2.11	GC 2.12



**GREEN INFRASTRUCTURE
TYPICAL DETAILS**
SAN FRANCISCO PUBLIC UTILITIES COMMISSION

DATE	JANUARY 2023
VERSION	3.0
REVISED	

GENERAL COMPONENTS
UTILITY CROSSINGS
DESIGNER NOTES (2 OF 2)

DWG NO.
**GC
2.2**

NOT FOR CONSTRUCTION - REFER TO USER GUIDE

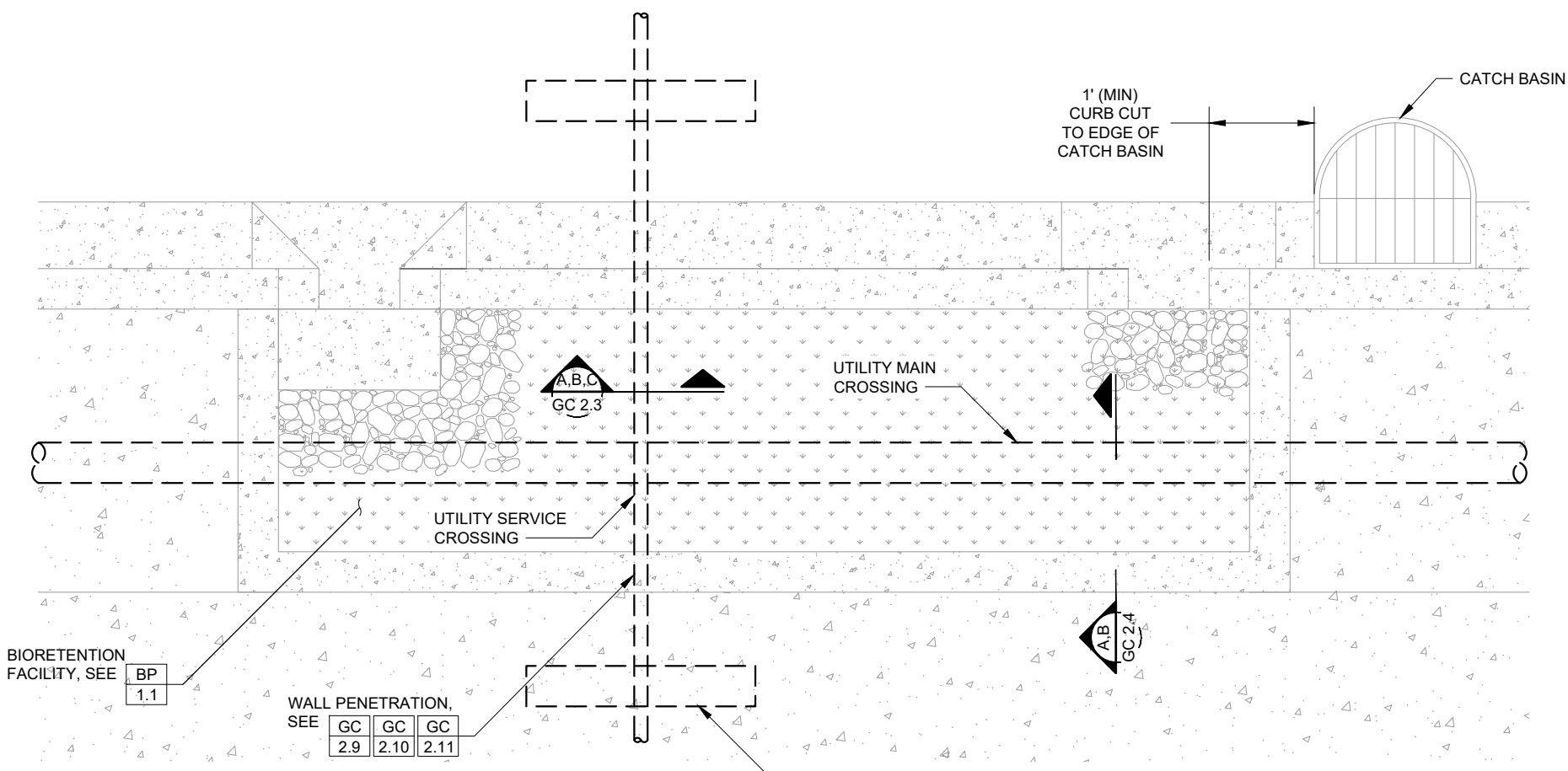

CONSTRUCTION NOTES:

1. ABANDONED UTILITIES WITHIN FOOTPRINT OF FACILITY AND OBSERVED DURING CONSTRUCTION MUST BE REMOVED. COORDINATE WITH MUNICIPAL OR PRIVATE OWNER AND ENGINEER.
2. PROVIDE UTILITY TRENCH DAM OR EQUIVALENT MEASURE OUTSIDE OF THE INFILTRATION FACILITY AT PIPE PENETRATIONS TO PREVENT PREFERENTIAL FLOW FROM INFILTRATION GALLERY INTO UTILITY TRENCHES. COORDINATE WITH ENGINEER.

UTILITY TRENCH DAM AS NEEDED (TYP). DESIGNER TO SPECIFY. SEE NOTE 2 AND

GC
2.12

NOTES		BIORETENTION			PERMEABLE PAVEMENT			WALL PENETRATIONS			TRENCH DAM
GC 2.1	GC 2.2	GC 2.3	GC 2.4	GC 2.5	GC 2.6	GC 2.7	GC 2.8	GC 2.9	GC 2.10	GC 2.11	GC 2.12



**GREEN INFRASTRUCTURE
TYPICAL DETAILS**
SAN FRANCISCO PUBLIC UTILITIES COMMISSION

DATE	JANUARY 2023
VERSION	3.0
REVISED	

GENERAL COMPONENTS
UTILITY CROSSINGS
BIORETENTION

DWG NO.

GC
2.3

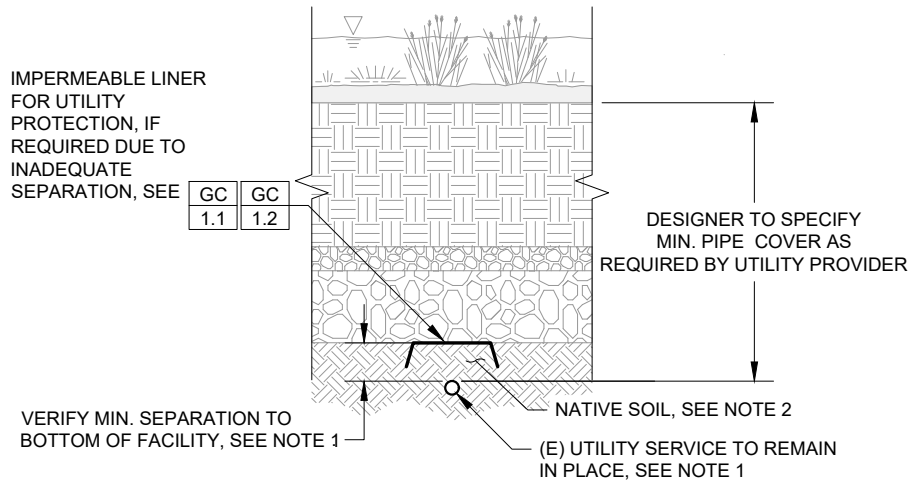

SHALLOW UTILITY SERVICE UNDER BIORETENTION FACILITY (A)

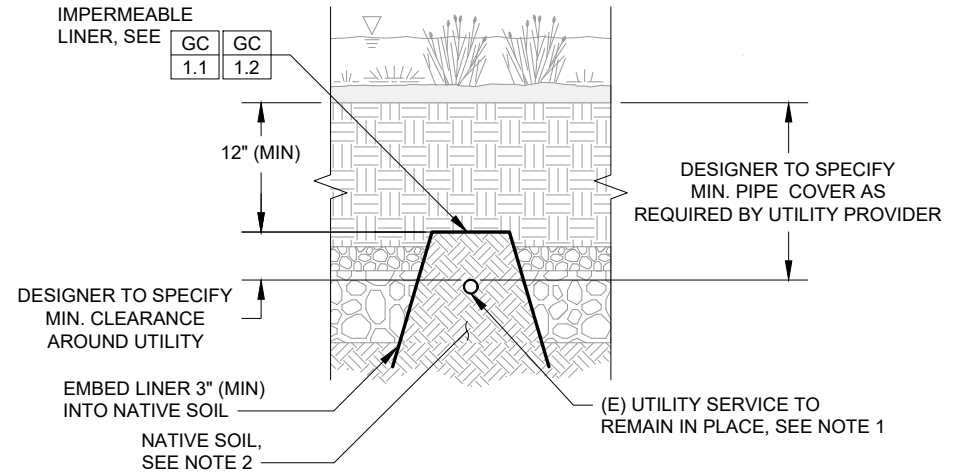

SHALLOW UTILITY SERVICE WITHIN BIORETENTION FACILITY (B)

CONSTRUCTION NOTES:

1. CONTRACTOR SHALL LOCATE AND DETERMINE DEPTH OF EXISTING UTILITY WITHIN THE FOOTPRINT OF THE BIORETENTION FACILITY WHILE LIMITING THE AMOUNT OF DISTURBANCE TO THE SOIL/BACKFILL MATERIAL OVER AND AROUND THE UTILITY PIPE. IF ELECTROMAGNETIC UTILITY LOCATING, POTHOLES, OR OTHER METHOD REVEALS THAT THE UTILITY PIPE DOES NOT MEET THE REQUIRED CLEARANCE FROM THE BOTTOM OF THE BIORETENTION FACILITY, THE UTILITY PROVIDER MAY REQUIRE THAT PROTECTION MEASURES, SUCH AS THOSE SHOWN ON THIS PLAN, BE IMPLEMENTED PER THEIR STANDARDS. ANY DISCREPANCIES BETWEEN THE EXISTING UTILITIES SHOWN IN THE DESIGN DRAWINGS AND THE ACTUAL FIELD CONDITIONS SHOULD BE COMMUNICATED TO THE ENGINEER IMMEDIATELY.
2. EXISTING UTILITIES AND NATIVE SOIL AROUND EXISTING UTILITIES SHOULD REMAIN IN PLACE WHERE POSSIBLE. IF A PORTION OR ALL OF THE UTILITY IS UNCOVERED DURING EXCAVATION OR EXISTING SOIL WITHIN 1 FOOT OF THE KNOWN EXISTING UTILITY IS SCARIFIED, NATIVE SOIL OR APPROVED ENGINEERED BACKFILL SHALL BE CAREFULLY PLACED AND COMPACTED AROUND THE UTILITY PER THE UTILITY PROVIDER'S REQUIREMENTS.
3. UTILITY PROVIDER MAY ALLOW UTILITY SERVICES TO BE LEFT IN PLACE AND WRAPPED WITH A WATERTIGHT WRAP OR TAPE IN LIEU OF A SLEEVE. THIS MUST BE APPROVED PRIOR TO THE START OF CONSTRUCTION.

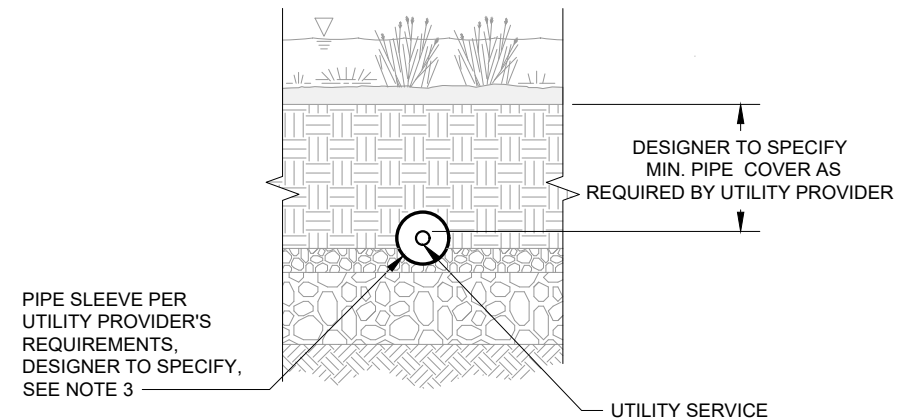

SLEEVED UTILITY SERVICE WITHIN BIORETENTION FACILITY (C)

NOTES		BIORETENTION			PERMEABLE PAVEMENT			WALL PENETRATIONS			TRENCH DAM
GC 2.1	GC 2.2	GC 2.3	GC 2.4	GC 2.5	GC 2.6	GC 2.7	GC 2.8	GC 2.9	GC 2.10	GC 2.11	GC 2.12



**GREEN INFRASTRUCTURE
TYPICAL DETAILS**
SAN FRANCISCO PUBLIC UTILITIES COMMISSION

DATE
JANUARY 2023
VERSION
3.0
REVISED

**GENERAL COMPONENTS
UTILITY CROSSINGS
BIORETENTION SECTIONS (1 OF 2)**

DWG NO.
**GC
2.4**

NOT FOR CONSTRUCTION - REFER TO USER GUIDE

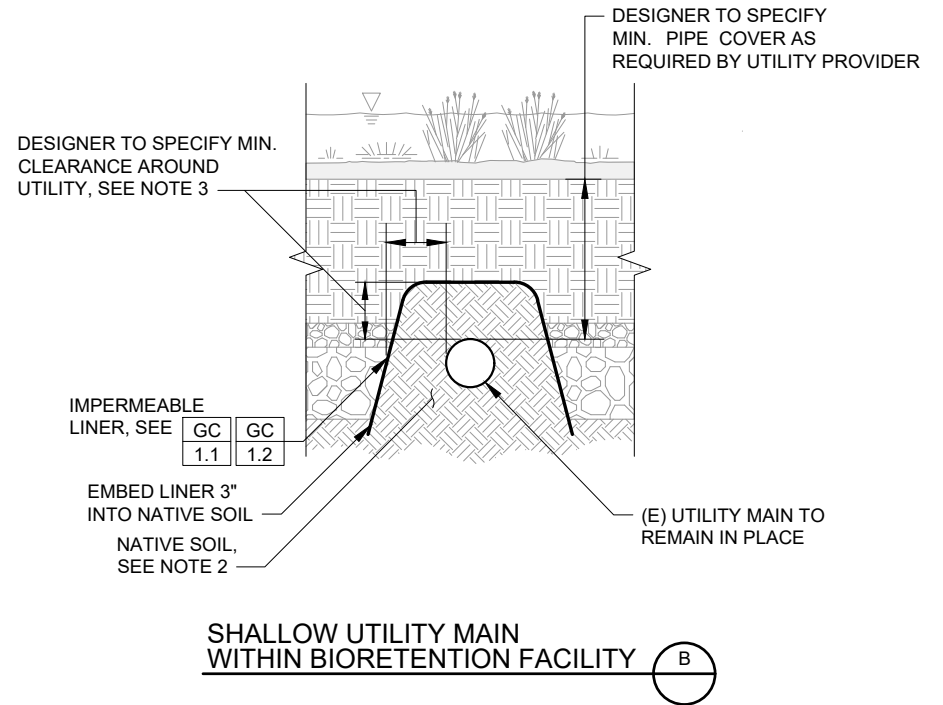
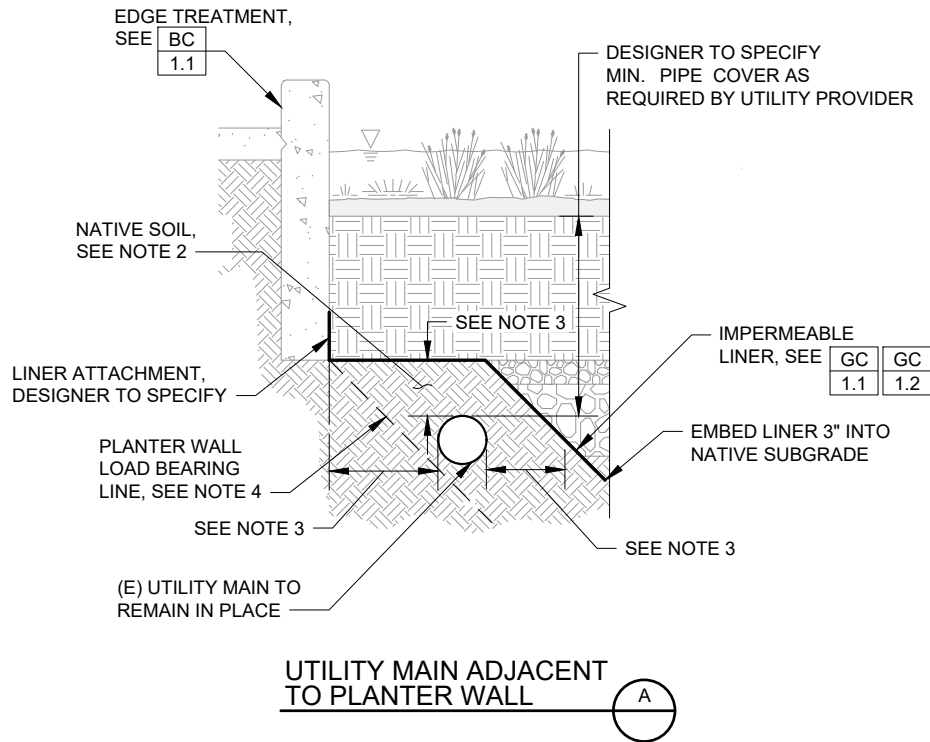

CONSTRUCTION NOTES:

1. ANY DISCREPANCIES BETWEEN THE EXISTING UTILITIES SHOWN IN THE DESIGN DRAWINGS AND THE ACTUAL FIELD CONDITIONS SHOULD BE COMMUNICATED TO THE ENGINEER IMMEDIATELY.
2. EXISTING UTILITIES AND NATIVE SOIL AROUND EXISTING UTILITIES SHOULD REMAIN IN PLACE WHERE POSSIBLE. IF A PORTION OR ALL OF THE UTILITY IS UNCOVERED DURING EXCAVATION OR EXISTING SOIL WITHIN 1 FOOT OF THE KNOWN EXISTING UTILITY IS SCARIFIED, NATIVE SOIL OR APPROVED ENGINEERED BACKFILL SHALL BE CAREFULLY PLACED AND COMPACTED AROUND THE UTILITY PER THE UTILITY PROVIDER'S REQUIREMENTS.
3. PROVIDE THE MINIMUM CLEARANCE AROUND THE UTILITY MAIN AND SETBACKS FROM STRUCTURAL ELEMENTS PER THE UTILITY PROVIDER'S REQUIREMENTS.
4. UTILITY MAINS SHALL NOT BE SUBJECT TO LOADING FROM NEW PLANTER WALLS. LOAD BEARING LINES TO BE DETERMINED BY THE GEOTECHNICAL ENGINEER.

NOTES		BIORETENTION			PERMEABLE PAVEMENT			WALL PENETRATIONS			TRENCH DAM
GC 2.1	GC 2.2	GC 2.3	GC 2.4	GC 2.5	GC 2.6	GC 2.7	GC 2.8	GC 2.9	GC 2.10	GC 2.11	GC 2.12



**GREEN INFRASTRUCTURE
TYPICAL DETAILS**
SAN FRANCISCO PUBLIC UTILITIES COMMISSION

DATE
JANUARY 2023
VERSION
3.0
REVISED

GENERAL COMPONENTS
UTILITY CROSSINGS
BIORETENTION SECTIONS (2 OF 2)

DWG NO.
**GC
2.5**

NOT FOR CONSTRUCTION - REFER TO USER GUIDE

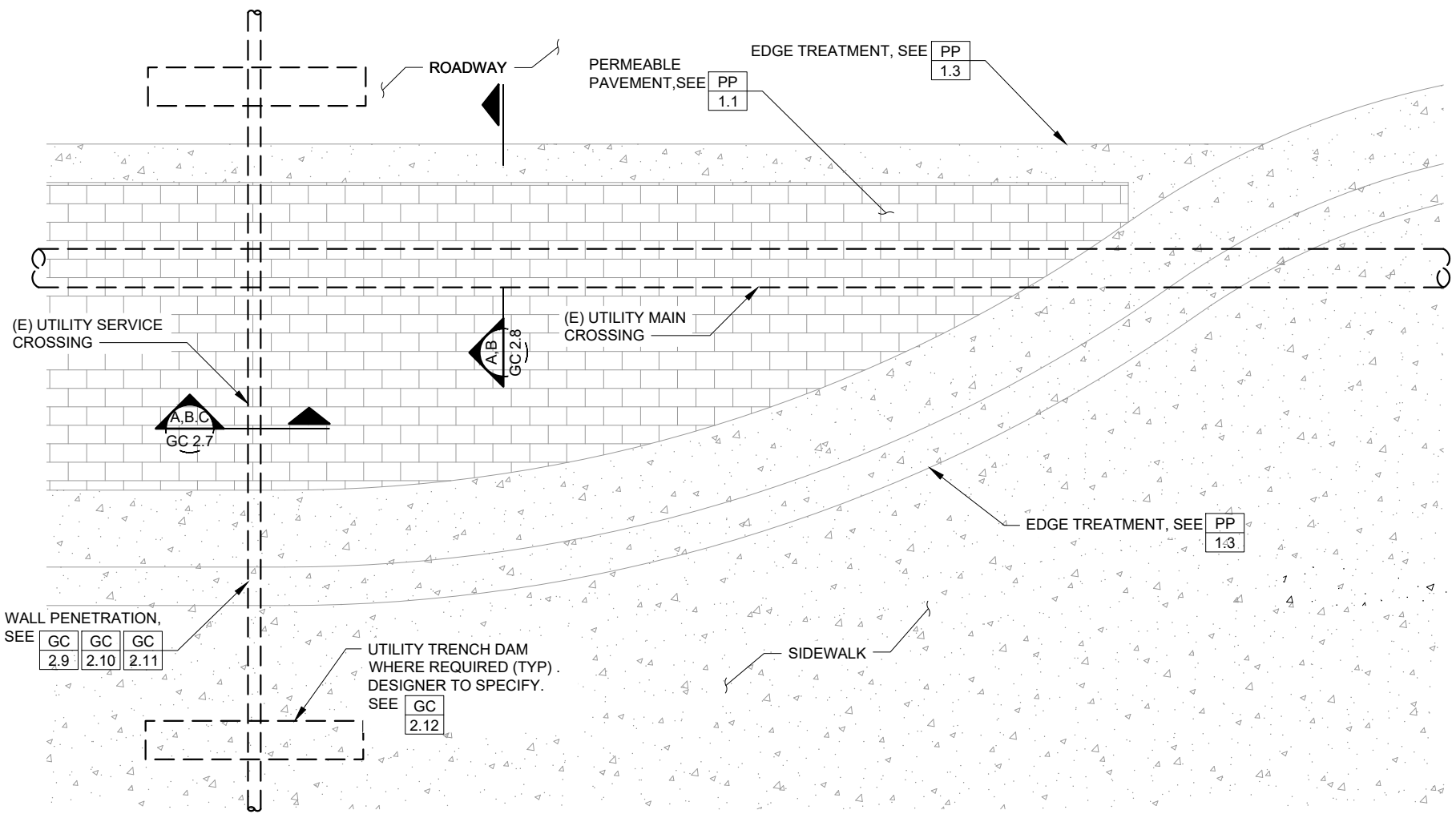

CONSTRUCTION NOTES:

1. ABANDONED UTILITIES WITHIN FOOTPRINT OF FACILITY AND OBSERVED DURING CONSTRUCTION MUST BE REMOVED. COORDINATE WITH MUNICIPAL OR PRIVATE OWNER AND ENGINEER.
2. PROVIDE UTILITY TRENCH DAM OR EQUIVALENT MEASURE OUTSIDE OF THE INFILTRATION FACILITY AT PIPE PENETRATIONS TO PREVENT PREFERENTIAL FLOW FROM INFILTRATION GALLERY INTO UTILITY TRENCHES. COORDINATE WITH ENGINEER.

NOTES		BIORETENTION			PERMEABLE PAVEMENT			WALL PENETRATIONS			TRENCH DAM
GC 2.1	GC 2.2	GC 2.3	GC 2.4	GC 2.5	GC 2.6	GC 2.7	GC 2.8	GC 2.9	GC 2.10	GC 2.11	GC 2.12



**GREEN INFRASTRUCTURE
TYPICAL DETAILS**
SAN FRANCISCO PUBLIC UTILITIES COMMISSION

DATE	JANUARY 2023
VERSION	3.0
REVISED	

GENERAL COMPONENTS
UTILITY CROSSINGS
PERMEABLE PAVEMENT

DWG NO.
GC 2.6

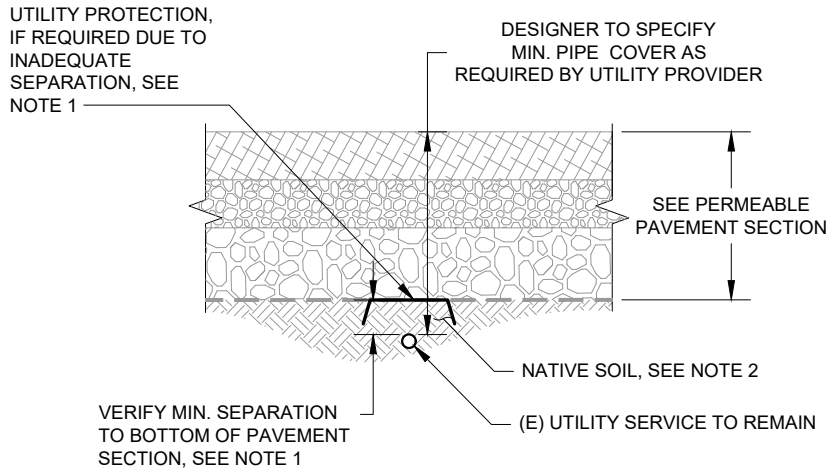

SHALLOW UTILITY SERVICE UNDER PERMEABLE PAVEMENT

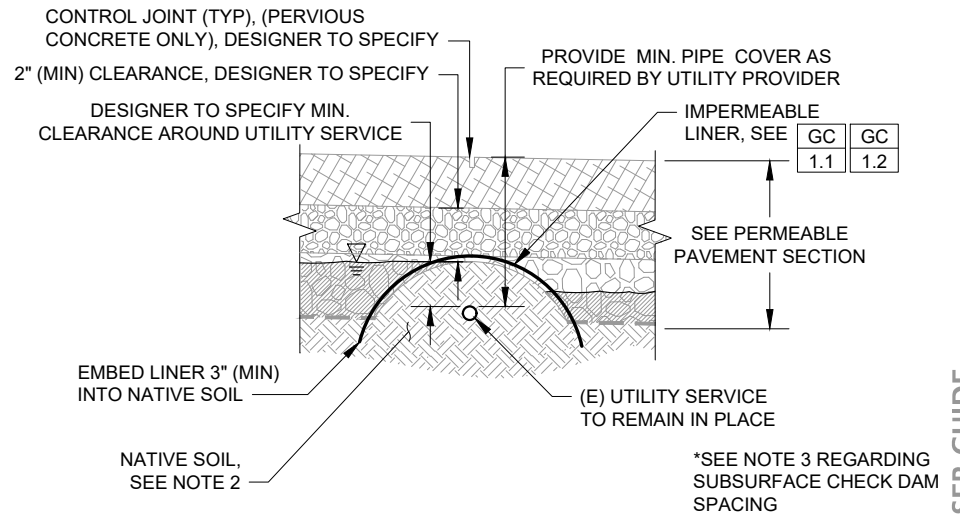

SHALLOW UTILITY SERVICE WITHIN SUBSURFACE CHECK DAM



CONSTRUCTION NOTES:

1. CONTRACTOR SHALL LOCATE AND DETERMINE DEPTH OF EXISTING UTILITY WITHIN THE FOOTPRINT OF THE PERMEABLE PAVEMENT FACILITY WHILE LIMITING THE AMOUNT OF DISTURBANCE TO THE SOIL/BACKFILL MATERIAL OVER AND AROUND THE UTILITY PIPE. IF ELECTROMAGNETIC UTILITY LOCATING, POTHOLING, OR OTHER METHOD REVEALS THAT THE UTILITY PIPE DOES NOT MEET THE REQUIRED SETBACK FROM THE BOTTOM OF THE PERMEABLE PAVEMENT SECTION, THE UTILITY PROVIDER MAY REQUIRE THAT PROTECTION MEASURES, SUCH AS THOSE SHOWN ON THIS PLAN, BE IMPLEMENTED.
2. EXISTING UTILITIES AND NATIVE SOIL AROUND EXISTING UTILITIES SHOULD REMAIN IN PLACE WHERE POSSIBLE. IF A PORTION OR ALL OF THE UTILITY IS UNCOVERED DURING EXCAVATION OR EXISTING SOIL WITHIN 1 FOOT OF THE KNOWN EXISTING UTILITY IS SCARIFIED, NATIVE SOIL OR APPROVED ENGINEERED BACKFILL SHALL BE CAREFULLY PLACED AND COMPACTED AROUND THE UTILITY PER THE UTILITY PROVIDER'S REQUIREMENTS.
3. THE CHECK DAM SPACING AND HEIGHT SPECIFIED ON THE DESIGN PLANS MUST BE MAINTAINED. IF THE CHECK DAM PROTECTING THE EXISTING UTILITY WILL IMPACT THE CHECK DAM SPACING SPECIFIED ON THE PLANS, COORDINATE WITH ENGINEER.
4. UTILITY PROVIDER MAY ALLOW SHALLOW UTILITY SERVICES TO BE LEFT IN PLACE AND WRAPPED WITH A WATERTIGHT WRAP OR TAPE IN LIEU OF A SLEEVE. THIS SHOULD BE APPROVED PRIOR TO THE START OF CONSTRUCTION.

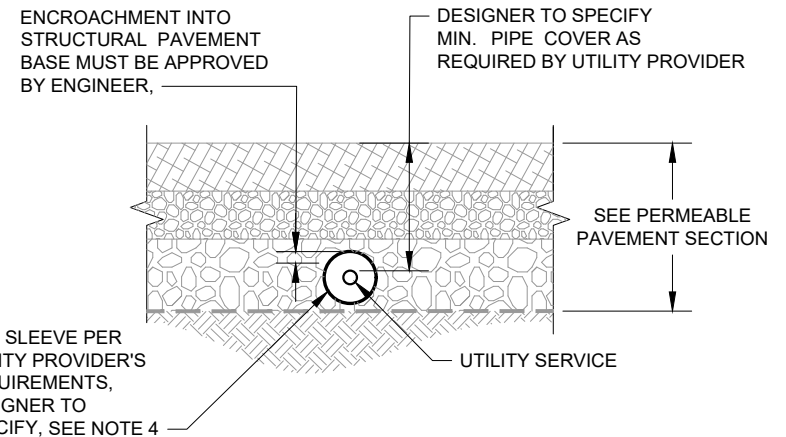

SLEEVED UTILITY SERVICE WITHIN PERMEABLE PAVEMENT



NOTES		BIORETENTION			PERMEABLE PAVEMENT			WALL PENETRATIONS			TRENCH DAM
GC 2.1	GC 2.2	GC 2.3	GC 2.4	GC 2.5	GC 2.6	GC 2.7	GC 2.8	GC 2.9	GC 2.10	GC 2.11	GC 2.12



GREEN INFRASTRUCTURE TYPICAL DETAILS
SAN FRANCISCO PUBLIC UTILITIES COMMISSION

DATE	JANUARY 2023
VERSION	3.0
REVISED	

GENERAL COMPONENTS UTILITY CROSSINGS PERMEABLE PAVEMENT SECTIONS (1 OF 2)

DWG NO.
GC 2.7

NOT FOR CONSTRUCTION - REFER TO USER GUIDE

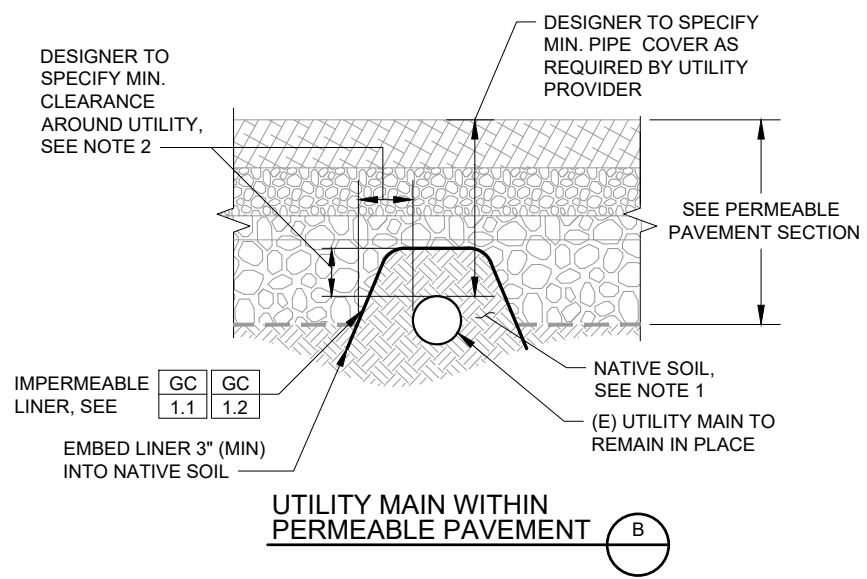
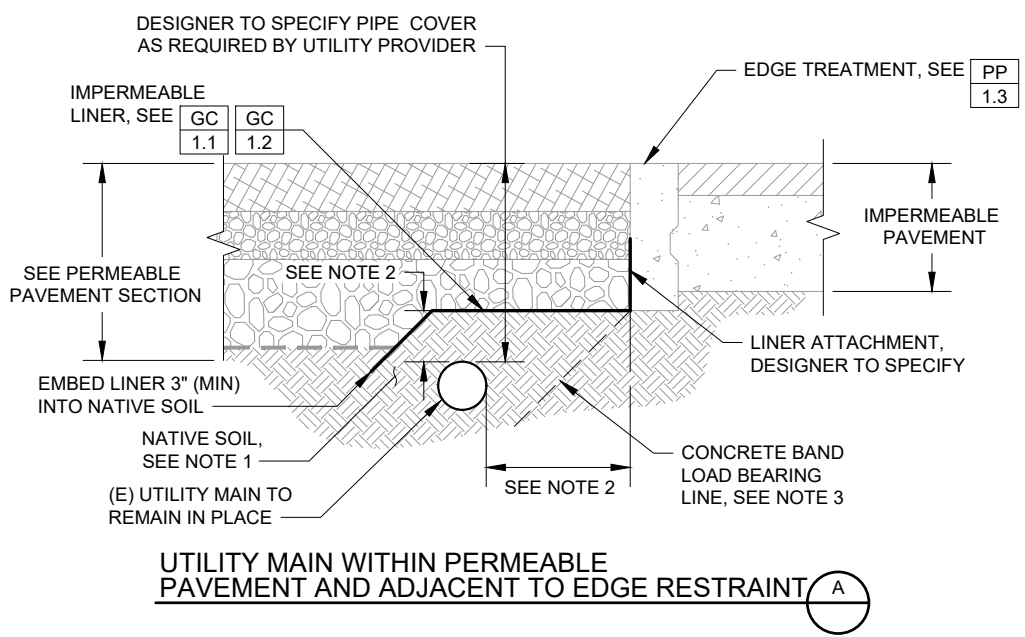

CONSTRUCTION NOTES:

1. EXISTING UTILITIES AND NATIVE SOIL AROUND EXISTING UTILITIES SHOULD REMAIN IN PLACE WHERE POSSIBLE. IF A PORTION OR ALL OF THE UTILITY IS UNCOVERED DURING EXCAVATION OR EXISTING SOIL WITHIN 1 FOOT OF THE KNOWN EXISTING UTILITY IS SCARIFIED, NATIVE SOIL OR APPROVED ENGINEERED BACKFILL SHALL BE CAREFULLY PLACED AND COMPACTED AROUND THE UTILITY PER THE UTILITY PROVIDER'S REQUIREMENTS.
2. PROVIDE THE MINIMUM CLEARANCE AROUND THE UTILITY MAIN AND SETBACKS FROM STRUCTURAL ELEMENTS PER THE UTILITY PROVIDER'S REQUIREMENTS.
3. UTILITY MAINS SHALL NOT BE SUBJECT TO LOADING FROM NEW CURBS/WALLS. LOAD BEARING LINES TO BE DETERMINED BY THE GEOTECHNICAL ENGINEER.

NOTES		BIORETENTION			PERMEABLE PAVEMENT			WALL PENETRATIONS			TRENCH DAM
GC 2.1	GC 2.2	GC 2.3	GC 2.4	GC 2.5	GC 2.6	GC 2.7	GC 2.8	GC 2.9	GC 2.10	GC 2.11	GC 2.12



**GREEN INFRASTRUCTURE
TYPICAL DETAILS**
SAN FRANCISCO PUBLIC UTILITIES COMMISSION

DATE	JANUARY 2023
VERSION	3.0
REVISED	

**GENERAL COMPONENTS
UTILITY CROSSINGS PERMEABLE
PAVEMENT SECTIONS (2 OF 2)**

DWG NO.
GC 2.8

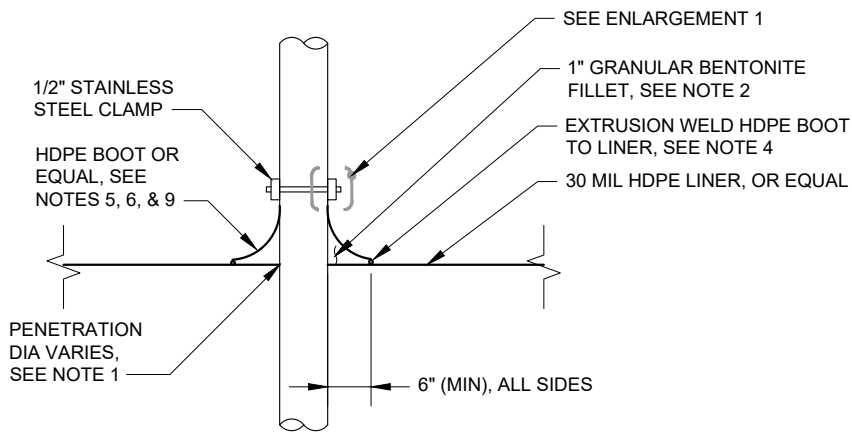

TYPICAL LINER PENETRATION - PERPENDICULAR

1

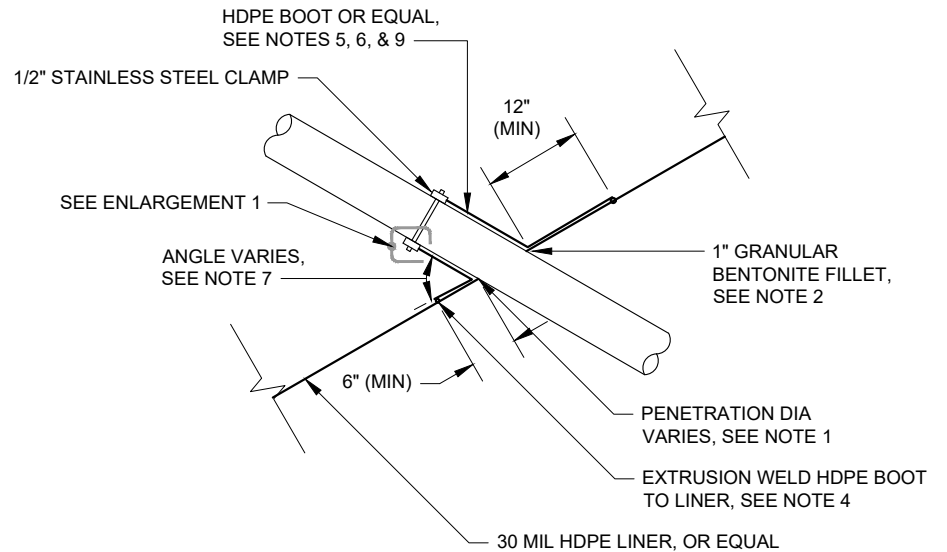

TYPICAL LINER PENETRATION - ANGLED

2

CONSTRUCTION NOTES:

1. CUT OPENING IN LINER FOR PIPE TO WITHIN 1/2" OF PIPE OUTSIDE DIAMETER.
2. FILL ANNULAR SPACE WITH 1" MINIMUM GRANULAR BENTONITE FILLET AS SHOWN.
3. APPLY BUTYL MASTIC CAULK AND NEOPRENE RUBBER PAD CONTINUOUSLY AROUND PIPE.
4. PROVIDE CONTINUOUS EXTRUSION WELD AT PIPE BOOT/LINER INTERFACE.
5. FORM BOOT WITH SUFFICIENT MATERIAL TO PREVENT OVERSTRESSING DURING BACKFILLING, BUT WITHOUT FOLDS OR WRINKLES.
6. CONSTRUCT BOOT FROM SAME MATERIAL AS THE LINER.
7. ANGLE SHOULD NOT BE LESS THAN 30°. IF ANGLE IS LESS THAN 30° ADD SOIL AROUND THE PIPE TO INCREASE THE ANGLE AND PREVENT STRESSING AND CRACKING.
8. SEAL CLAMP AND END OF BOOT WITH HEAT SHRINK WRAP. EXTEND HEAT SHRINK WRAP ONE PIPE DIAMETER (MINIMUM) BEYOND CLAMP.
9. CONTRACTOR MAY USE PREFABRICATED PIPE BOOTS IN LIEU OF FIELD-FABRICATED BOOTS. CONNECT PREFABRICATED BOOT TO LINER AND PIPE PER MANUFACTURER'S RECOMMENDATIONS.

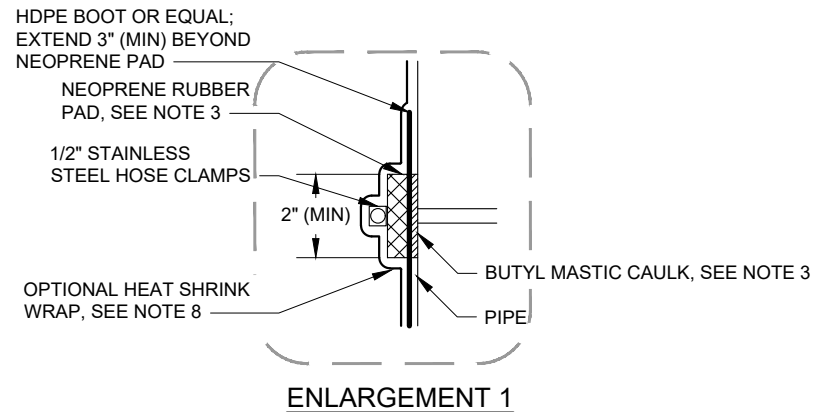

NOTES		BIORETENTION			PERMEABLE PAVEMENT			WALL PENETRATIONS			TRENCH DAM
GC 2.1	GC 2.2	GC 2.3	GC 2.4	GC 2.5	GC 2.6	GC 2.7	GC 2.8	GC 2.9	GC 2.10	GC 2.11	GC 2.12



**GREEN INFRASTRUCTURE
TYPICAL DETAILS**
SAN FRANCISCO PUBLIC UTILITIES COMMISSION

DATE
JANUARY 2023
VERSION
3.0
REVISED

GENERAL COMPONENTS
UTILITY CROSSINGS
LINER PENETRATIONS

DWG NO.
GC 2.9

NOT FOR CONSTRUCTION - REFER TO USER GUIDE

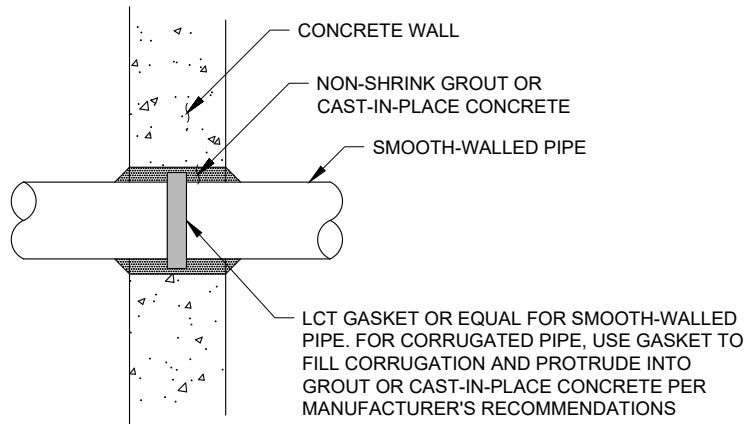

TYPICAL WATERTIGHT WALL PENETRATION - ALTERNATE 1 1

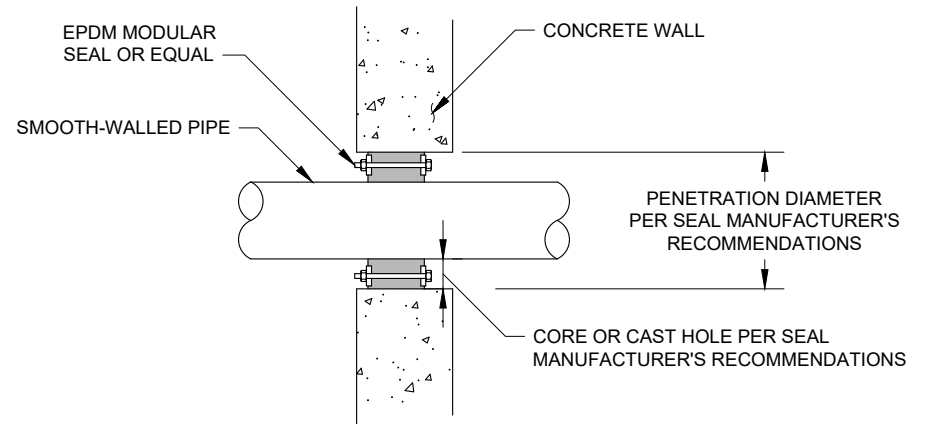

TYPICAL WATERTIGHT WALL PENETRATION - ALTERNATE 2 2

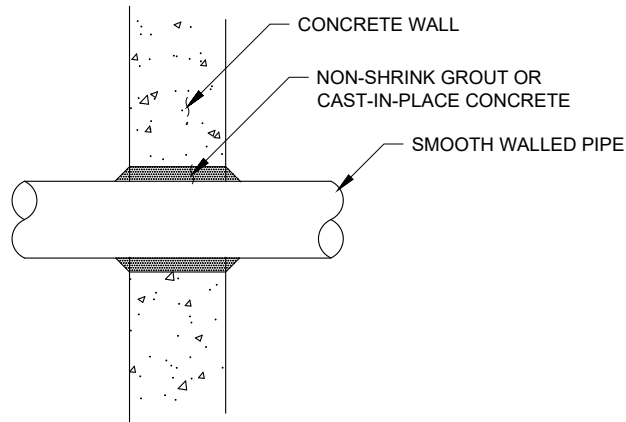

TYPICAL SOIL TIGHT WALL PENETRATION 3

NOTES		BIORETENTION			PERMEABLE PAVEMENT			WALL PENETRATIONS			TRENCH DAM
GC 2.1	GC 2.2	GC 2.3	GC 2.4	GC 2.5	GC 2.6	GC 2.7	GC 2.8	GC 2.9	GC 2.10	GC 2.11	GC 2.12

NOT FOR CONSTRUCTION - REFER TO USER GUIDE



**GREEN INFRASTRUCTURE
TYPICAL DETAILS**
SAN FRANCISCO PUBLIC UTILITIES COMMISSION

DATE	JANUARY 2023
VERSION	3.0
REVISED	

GENERAL COMPONENTS
UTILITY CROSSINGS
WALL PENETRATIONS (1 OF 2)

DWG NO.
**GC
2.10**

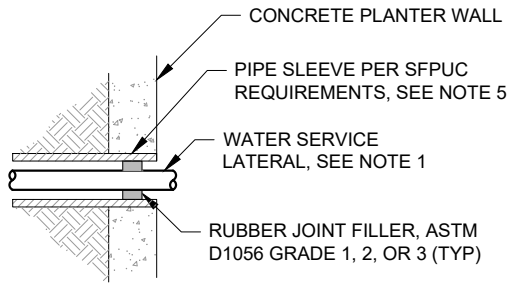

WALL PENETRATION
FOR WATER LATERALS (1)

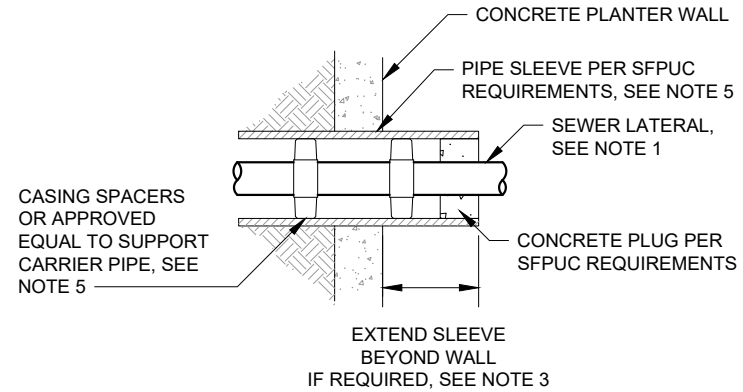

WALL PENETRATION
FOR SEWER LATERALS (2)

CONSTRUCTION NOTES:

1. IN CASES WHERE SHALLOW EXISTING UTILITIES, SUCH AS STREET LIGHT CONDUIT, HAVE BEEN APPROVED TO REMAIN IN PLACE PER THE UTILITY PROVIDER, AND SLEEVING FROM ONE END IS NOT FEASIBLE, THE EXISTING UTILITIES SHALL BE CAREFULLY WRAPPED WITH AN INSULATION MATERIAL (MIN. 1" THICK) AND A WATERTIGHT TAPE UNTIL THE WALLS ARE FORMED AROUND THE PIPE CROSSINGS. ONCE THE WALLS ARE SET, THE INSULATION WRAP SHALL BE REMOVED AND THE WALL PENETRATIONS SEALED.
2. DETECTABLE UTILITY MARKING TAPE SHALL BE PLACED OVER ALL UTILITIES WITHIN THE FOOTPRINT OF BIORETENTION FACILITIES. REFER TO THE TAPE MANUFACTURER'S RECOMMENDATIONS FOR MAXIMUM TAPE BURIAL DEPTH.
3. IF SEWER LATERAL IS BELOW BOTTOM OF BIORETENTION FACILITY AND WALL PENETRATION IS NOT NECESSARY, THE CITY MAY REQUIRE THE SLEEVE AROUND NEW LATERAL PIPE TO BE EXTENDED BEYOND THE OUTSIDE OF THE PLANTER ON THE SIDEWALK SIDE. SEE DESIGN DRAWINGS FOR FURTHER DIRECTION.
4. ALL OTHER REPLACED OR NEW UTILITY SERVICES, SUCH AS GAS, TELECOM, ELECTRICAL, AND IRRIGATION RUNNING THROUGH A BIORETENTION FACILITY SHALL BE SLEEVED AND WALL PENETRATIONS SHALL BE DESIGNED TO MEET UTILITY PROVIDER'S REQUIREMENTS.
5. PIPE SLEEVE DESIGN AND MATERIALS, CONFORMING TO SFPUC STANDARDS, SHALL BE SPECIFIED ON THE DESIGN DRAWINGS.

NOTES		BIORETENTION			PERMEABLE PAVEMENT			WALL PENETRATIONS		TRENCH DAM	
GC 2.1	GC 2.2	GC 2.3	GC 2.4	GC 2.5	GC 2.6	GC 2.7	GC 2.8	GC 2.9	GC 2.10	GC 2.11	GC 2.12



**GREEN INFRASTRUCTURE
TYPICAL DETAILS**
SAN FRANCISCO PUBLIC UTILITIES COMMISSION

DATE	JANUARY 2023
VERSION	3.0
REVISED	

**GENERAL COMPONENTS
UTILITY CROSSINGS
WALL PENETRATIONS (2 OF 2)**

DWG NO.
**GC
2.11**

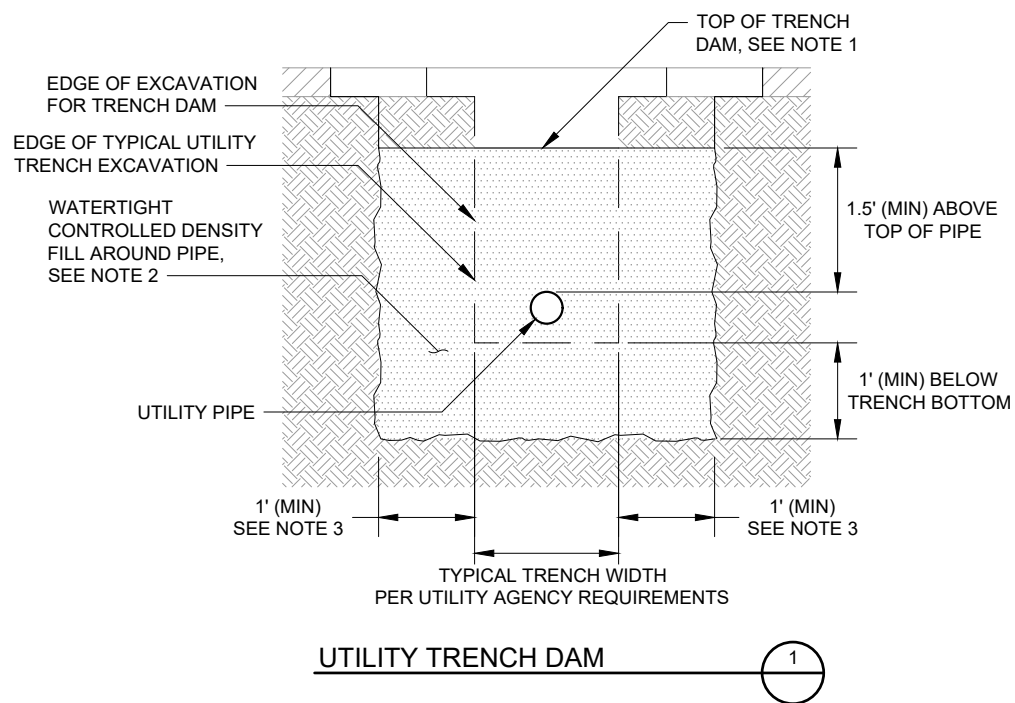

UTILITY TRENCH DAM 1

CONSTRUCTION NOTES:

1. REFER TO DESIGN PLANS FOR TRENCH DAM LOCATIONS.
2. CONTROLLED DENSITY FILL SHALL BE 100 - 150 PSI STRENGTH WITH A WATER CONDUCTIVITY OF 1.0×10^{-6} CM/SEC (MAX).
3. TRENCH DAM SHALL EXTEND BEYOND THE EXISTING UTILITY TRENCH INTO THE NATIVE SOIL PER THE MINIMUM DIMENSIONS SHOWN. THE TRENCH DAM SHALL HAVE A MINIMUM THICKNESS OF 1' (MEASURED PARALLEL TO THE UTILITY PIPE LENGTH).

NOTES		BIORETENTION			PERMEABLE PAVEMENT			WALL PENETRATIONS			TRENCH DAM
GC 2.1	GC 2.2	GC 2.3	GC 2.4	GC 2.5	GC 2.6	GC 2.7	GC 2.8	GC 2.9	GC 2.10	GC 2.11	GC 2.12



**GREEN INFRASTRUCTURE
TYPICAL DETAILS**
SAN FRANCISCO PUBLIC UTILITIES COMMISSION

DATE	JANUARY 2023
VERSION	3.0
REVISED	

GENERAL COMPONENTS
UTILITY CROSSINGS
UTILITY TRENCH DAM

DWG NO.
**GC
2.12**

UPDATE IN PROGRESS
Coordinate with SF Power

NOT FOR CONSTRUCTION - REFER TO USER GUIDE

NOTES
GC
3.1

COMPONENTS		
GC	GC	GC
3.2	3.3	3.4



San Francisco
**Water
Power
Sewer**

**GREEN INFRASTRUCTURE
TYPICAL DETAILS**

SAN FRANCISCO PUBLIC UTILITIES COMMISSION

DATE
JANUARY 2023

VERSION
3.0

REVISED

GENERAL COMPONENTS
UTILITY CONFLICTS
DESIGNER NOTES

DWG NO.

**GC
3.1**

UPDATE IN PROGRESS
 Coordinate with SF Power

NOT FOR CONSTRUCTION - REFER TO USER GUIDE

NOTES

GC
3.1

COMPONENTS

GC	GC	GC
3.2	3.3	3.4



San Francisco
**Water
 Power
 Sewer**

**GREEN INFRASTRUCTURE
 TYPICAL DETAILS**
 SAN FRANCISCO PUBLIC UTILITIES COMMISSION

DATE	JANUARY 2023
VERSION	3.0
REVISED	

GENERAL COMPONENTS
 UTILITY CONFLICTS
 STREET/TRAFFIC LIGHT POLES (1 OF 2)

DWG NO.
**GC
 3.2**

UPDATE IN PROGRESS
 Coordinate with SF Power

NOT FOR CONSTRUCTION - REFER TO USER GUIDE

NOTES	COMPONENTS			
GC 3.1	GC 3.2	GC 3.3	GC 3.4	



San Francisco
**Water
 Power
 Sewer**

**GREEN INFRASTRUCTURE
 TYPICAL DETAILS**
 SAN FRANCISCO PUBLIC UTILITIES COMMISSION

DATE	JANUARY 2023
VERSION	3.0
REVISED	

GENERAL COMPONENTS
 UTILITY CONFLICTS
 STREET/TRAFFIC LIGHT POLES (2 OF 2)

DWG NO.
**GC
 3.3**

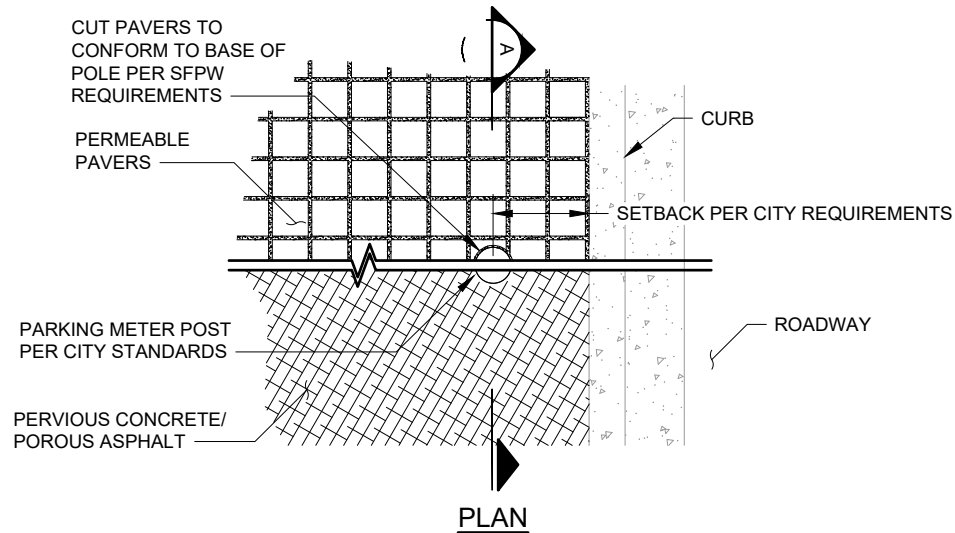

CONSTRUCTION NOTES:

1. DUE TO THE ADDED COMPLEXITY OF INSTALLING PERVIOUS CONCRETE AND POROUS ASPHALT AROUND NUMEROUS POLES/POSTS, IT IS RECOMMENDED POST HOLES BE DRILLED OUT AFTER THE PERVIOUS CONCRETE/POROUS ASPHALT HAS CURED. IF POLES ARE INSTALLED PRIOR TO THE PLACEMENT OF PERVIOUS CONCRETE/POROUS ASPHALT, THE CONTRACTOR SHALL COORDINATE WITH THE DESIGNER ON HOW THE PERVIOUS CONCRETE/POROUS ASPHALT SHALL BE INSTALLED AROUND AND/OR OVER THE POLE BASES.
2. WHERE METER POLES ARE SHOWN WITHIN A PERMEABLE PAVER AREA, THE BASES OF THE POLES SHALL BE INSTALLED BEFORE THE PAVER INSTALLATION. THE DESIGNER MAY SPECIFY THAT THE TOP OF THE BASES BE SET (OR CUT DOWN) AT A DEPTH THAT ALLOWS THE PAVERS AND LEVELING COURSE TO COVER THE TOP OF THE BASE AND REMAIN FLUSH WITH THE SURROUNDING PAVEMENT.
3. INSTALL PERMEABLE PAVEMENT OVER TOP OF FOOTING PER PROJECT SPECIFICATIONS AND MANUFACTURER'S RECOMMENDATIONS.
4. AVOID OVER-COMPACTION OF EXISTING SUBGRADE BELOW PERMEABLE PAVEMENT DURING CONSTRUCTION.

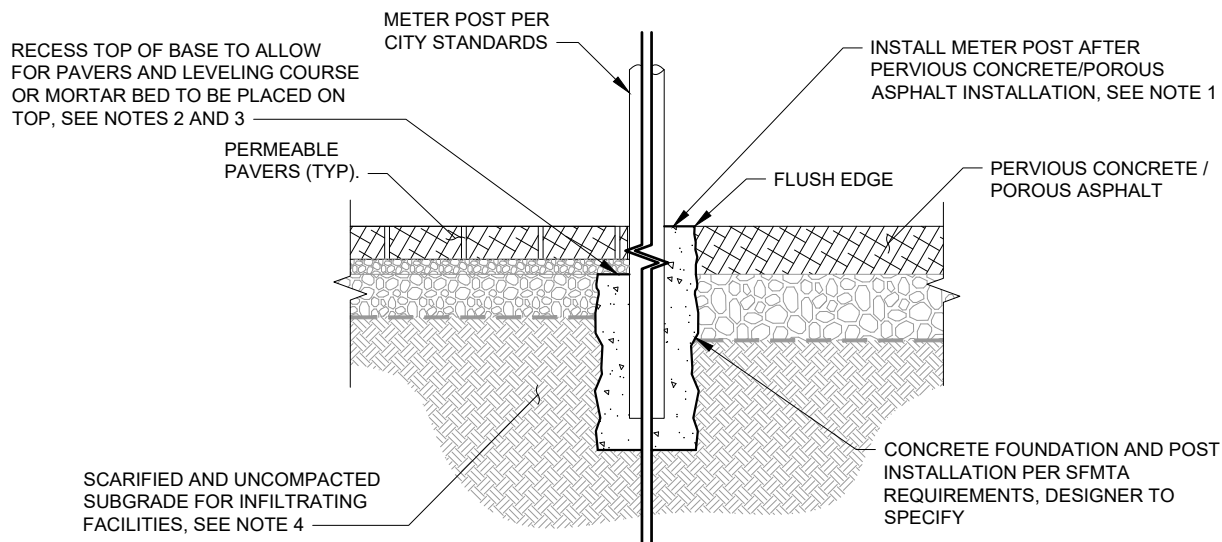

SECTION A
PARKING METER AT PERMEABLE PAVEMENT ①

NOTES	COMPONENTS		
GC 3.1	GC 3.2	GC 3.3	GC 3.4



**GREEN INFRASTRUCTURE
 TYPICAL DETAILS**
 SAN FRANCISCO PUBLIC UTILITIES COMMISSION

DATE	JANUARY 2023
VERSION	3.0
REVISED	

GENERAL COMPONENTS
 UTILITY CONFLICTS
 PARKING METERS

DWG NO.
GC 3.4

NOT FOR CONSTRUCTION - REFER TO USER GUIDE

PURPOSE:

OBSERVATION PORTS ALLOW FOR MEASUREMENT OF DRAWDOWN THROUGH A FACILITY (WHEN WATER LEVEL MEASUREMENTS ARE NOT OBSERVABLE AT THE SURFACE). THESE PORTS CAN ALSO BE USED FOR LONG-TERM MONITORING WITH A PRESSURE TRANSDUCER. FOR SYSTEMS INCLUDING UNDERDRAINS, CLEANOUTS MAY SERVE AS THE FACILITY OBSERVATION PORT PROVIDED LONG-TERM MONITORING IS NOT REQUIRED FOR THE FACILITY.

DESIGNER NOTES & GUIDELINES:

1. THE DESIGNER MUST ADAPT DRAWINGS TO ADDRESS SITE-SPECIFIC CONDITIONS.
2. OBSERVATION PORTS WITHIN A BIORETENTION FACILITY ARE NOT REQUIRED TO INCLUDE A SEPARATE LOCKING COVER ASSEMBLY. HOWEVER, DESIGNERS SHOULD CONSIDER REQUIRING A LOCKING OBSERVATION PORT CAP OR PLUG IF THE RISK OF TAMPERING IS CONSIDERED TO BE HIGH.
3. WHENEVER FEASIBLE, OBSERVATION PORTS SHOULD BE LOCATED OUTSIDE OF THE TRAVELED WAY. IF SITE CONSTRAINTS NECESSITATE INSTALLATION OF OBSERVATION PORTS IN AN AREA SUBJECT TO VEHICULAR TRAFFIC OR OTHER LOADING, OBSERVATION PORT COVER ASSEMBLIES AND MANHOLES MUST BE DESIGNED TO WITHSTAND ANTICIPATED LOADING (E.G., H-20).
4. OBSERVATION PORTS SHOULD INCLUDE A 12 INCH WATERTIGHT SUMP TO ACCOMMODATE CONTINUOUS WATER LEVEL MEASUREMENT WITH A PRESSURE TRANSDUCER.

DESIGNER CHECKLIST (MUST SPECIFY, AS APPLICABLE):

- OBSERVATION PORT MATERIAL, DIAMETER, AND DEPTH
- OBSERVATION PORT COVER ASSEMBLY/MANHOLE TYPE AND SIZE (IF APPLICABLE)
- CONTROL ELEVATIONS FOR OBSERVATION PORT RIMS
- TYPE OF MONITORING EQUIPMENT TO BE INSTALLED (IF APPLICABLE)

NOT FOR CONSTRUCTION - REFER TO USER GUIDE

NOTES	COMPONENTS	
GC 4.1	GC 4.2	GC 4.3



**GREEN INFRASTRUCTURE
TYPICAL DETAILS**
SAN FRANCISCO PUBLIC UTILITIES COMMISSION

DATE	JANUARY 2023
VERSION	3.0
REVISED	

**GENERAL COMPONENTS
OBSERVATION PORT
DESIGNER NOTES**

DWG NO.
**GC
4.1**

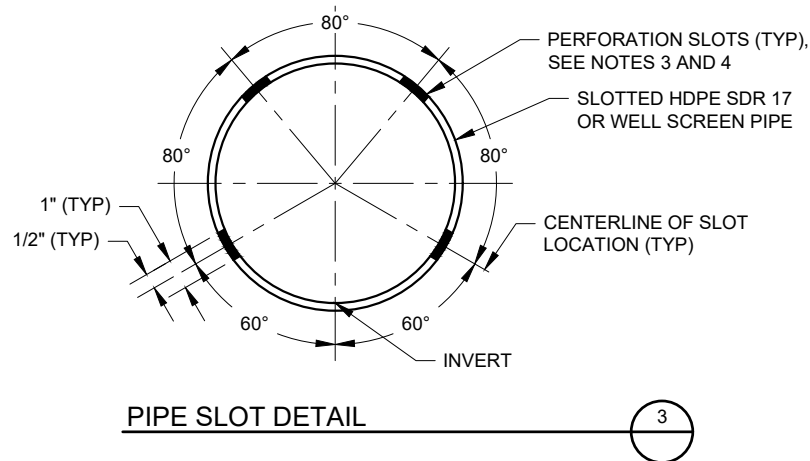
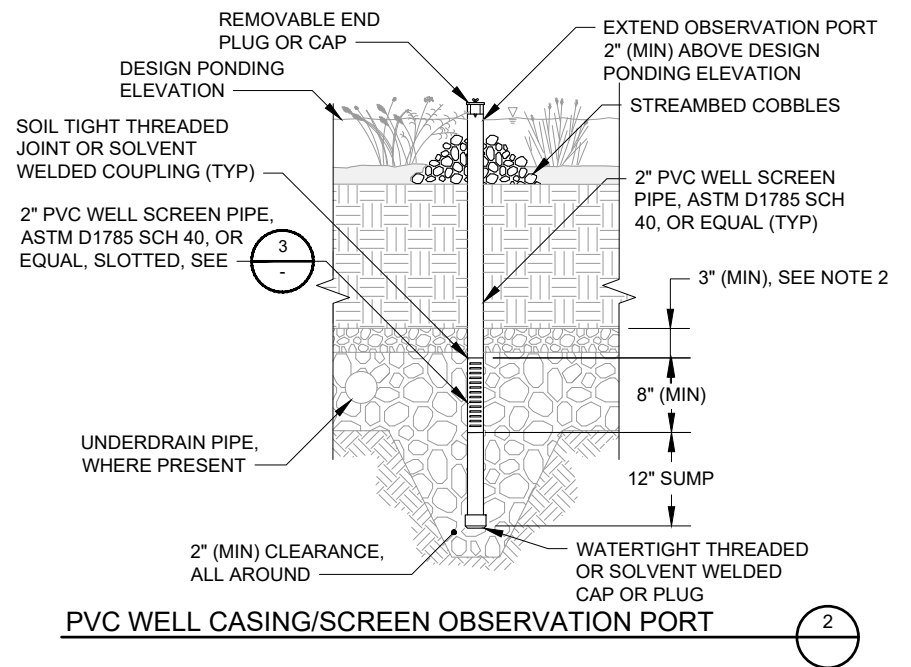
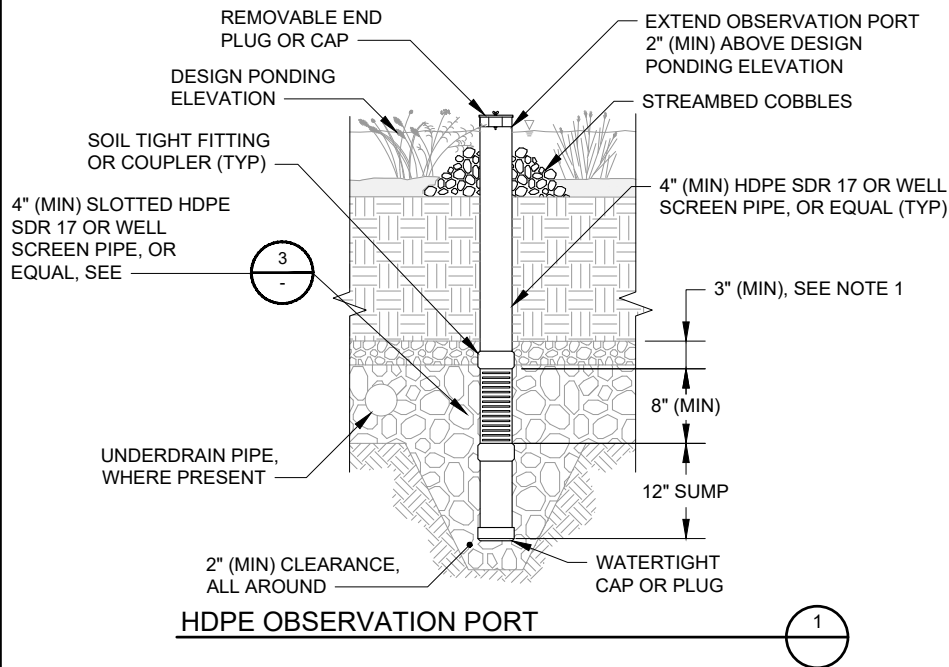

CONSTRUCTION NOTES:

1. ALL MATERIAL AND WORKMANSHIP FOR OBSERVATION PORTS SHALL CONFORM TO SAN FRANCISCO STANDARD SPECIFICATIONS AND APPLICABLE CODES PER SAN FRANCISCO DBI AND PUBLIC WORKS.
2. PROVIDE 3 INCH MINIMUM COVER FROM BOTTOM OF BIORETENTION SOIL TO BEGINNING OF OBSERVATION PORT PERFORATIONS.
3. ALL PERFORATIONS SHALL BE SLOTTED TYPE, MEASURING 0.064 INCH WIDE (MAX), SPACED AT 0.30 INCH ON CENTER, AND PROVIDING A MINIMUM INLET AREA OF 10.0 SQUARE INCH PER LINEAR FOOT OF PIPE. OTHER SLOT CONFIGURATIONS PROVIDING A MINIMUM INLET AREA OF 10.0 SQUARE INCHES PER LINEAR FOOT OF PIPE MAY BE SUBMITTED FOR APPROVAL BY SFPUC.
4. SLOTS SHALL BE ORIENTED PERPENDICULAR TO LONG AXIS OF PIPE, AND EVENLY SPACED AROUND CIRCUMFERENCE AND LENGTH OF PIPE.
5. ALL FITTINGS SHALL BE SOIL TIGHT, UNLESS NOTED OTHERWISE.

NOTES	COMPONENTS	
GC 4.1	GC 4.2	GC 4.3



**GREEN INFRASTRUCTURE
TYPICAL DETAILS**
SAN FRANCISCO PUBLIC UTILITIES COMMISSION

DATE
JANUARY 2023
VERSION
3.0
REVISED

**GENERAL COMPONENTS
OBSERVATION PORT
BIORETENTION**

DWG NO.
**GC
4.2**

NOT FOR CONSTRUCTION - REFER TO USER GUIDE

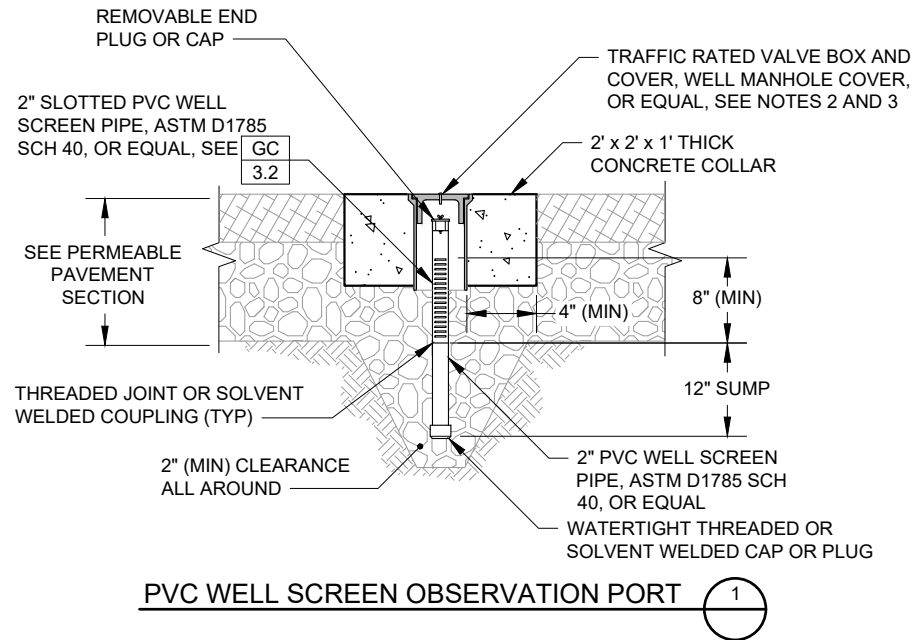

CONSTRUCTION NOTES:

1. ALL MATERIAL AND WORKMANSHIP FOR OBSERVATION PORTS SHALL CONFORM TO SAN FRANCISCO STANDARD SPECIFICATIONS AND APPLICABLE CODES PER SAN FRANCISCO DBI AND PUBLIC WORKS.
2. COVER SHALL BE TRAFFIC RATED WITH TAMPER RESISTANT LOCKING MECHANISM. COVER SHALL INCLUDE CASTING OF STANDARD TRIANGLE SYMBOL, "TEST WELL", "MONITORING WELL", OR EQUAL.
3. OBSERVATION PORT COVERS AND LIDS MUST COMPLY WITH SFPW STANDARD ACCESSIBILITY REQUIREMENTS.
4. WELL SCREEN SLOTS SHALL BE 0.032 INCHES WIDE (MAX), SPACED AT 0.25 INCH (MIN), AND PROVIDE A MINIMUM INLET AREA OF 2.0 SQUARE INCH PER LINEAR FOOT OF PIPE.
5. ALL FITTINGS SHALL BE SOIL TIGHT, UNLESS NOTED OTHERWISE.

NOTES	COMPONENTS	
GC 4.1	GC 4.2	GC 4.3



**GREEN INFRASTRUCTURE
TYPICAL DETAILS**
SAN FRANCISCO PUBLIC UTILITIES COMMISSION

DATE	JANUARY 2023
VERSION	3.0
REVISED	

**GENERAL COMPONENTS
OBSERVATION PORT
PERMEABLE PAVEMENT**

DWG NO.
**GC
4.3**

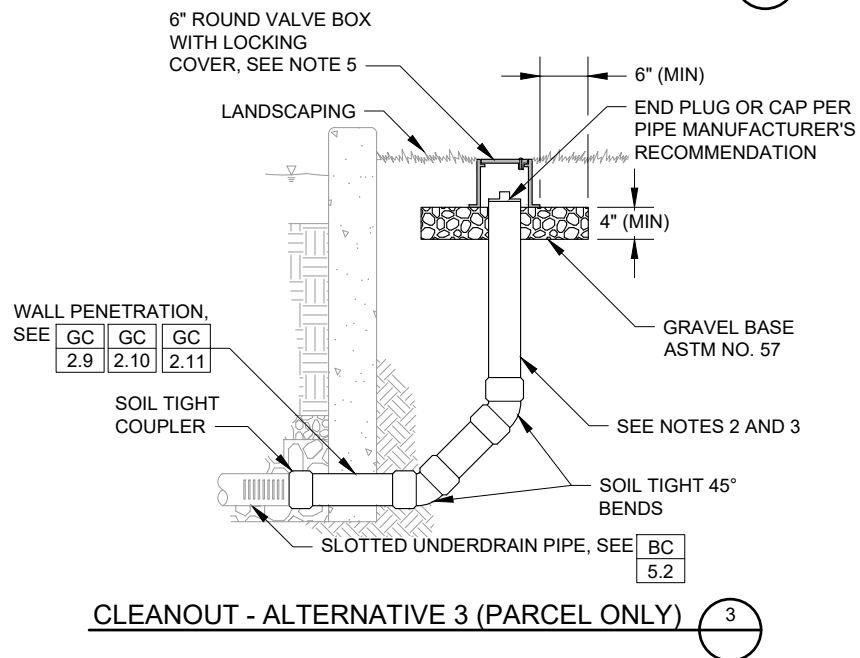
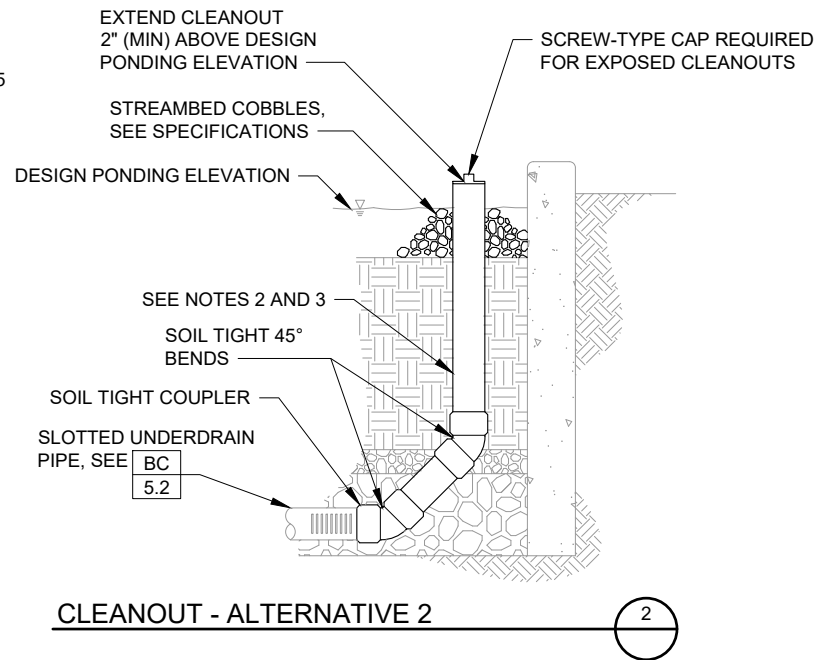
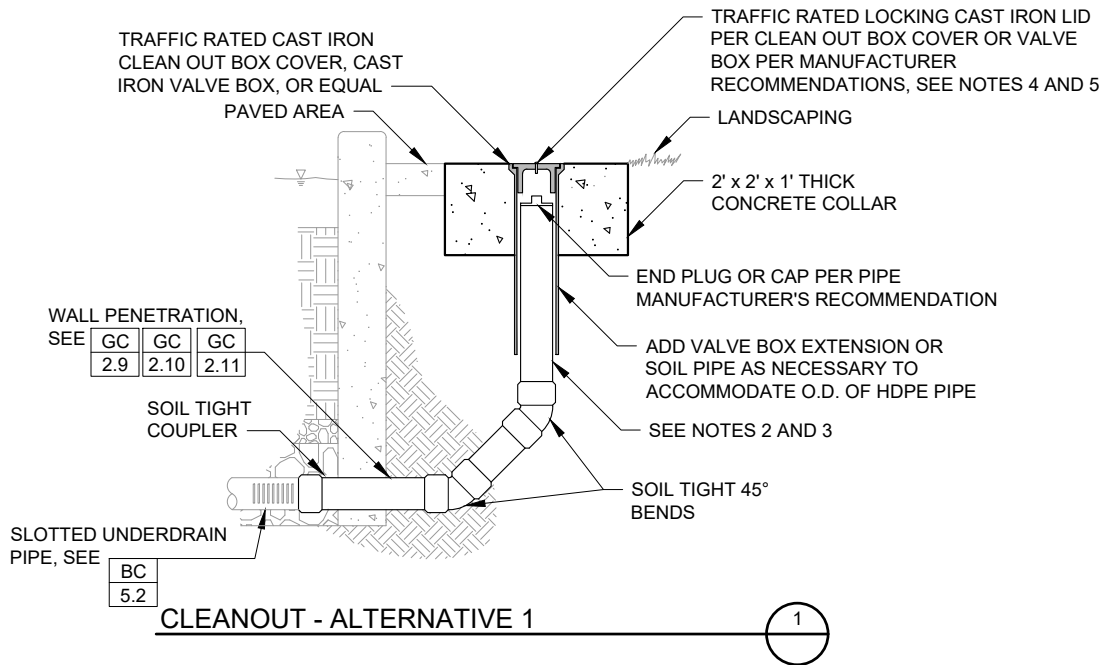

CONSTRUCTION NOTES:

1. ALL MATERIAL AND WORKMANSHIP FOR CLEANOUTS SHALL CONFORM TO SAN FRANCISCO STANDARD SPECIFICATIONS AND APPLICABLE CODES PER SAN FRANCISCO DBI AND PUBLIC WORKS.
2. PVC PIPE IS NOT ALLOWED FOR CITY PROJECTS AND CITY ACCEPTED ASSETS (REFER TO SF ENVIRONMENT CODE CHAPTER 5 SECTION 509 FOR ACCEPTABLE MATERIALS).
3. SLOTTED UNDERDRAIN, CLEANOUT PIPE, AND FITTINGS SHALL BE OF THE SAME SIZE AND MATERIALS (I.E., SDR 35 OR EQUAL FOR PARCEL PROJECTS, SDR 17 OR EQUAL FOR ROW PROJECTS).
4. COVER SHALL BE TRAFFIC RATED WITH TAMPER RESISTANT LOCKING MECHANISM. COVER SHALL INCLUDE CASTING OF "CO" OR EQUAL.
5. CLEANOUT COVERS AND LIDS MUST COMPLY WITH SAN FRANCISCO PUBLIC WORKS STANDARD ACCESSIBILITY REQUIREMENTS.
6. CLEANOUT SHALL BE INSTALLED TO ALLOW FOR MAINTENANCE ACCESS TO ALL PIPES.
7. ALL FITTINGS SHALL BE SOIL TIGHT.



PURPOSE:

END-OF-BLOCK MONITORING SYSTEMS ARE DESIGNED TO MONITOR FLOWS EXITING AN END-OF-BLOCK CATCH BASIN. THESE FLOWS ARE TYPICALLY VERY SMALL, REQUIRING THE USE OF SENSITIVE EQUIPMENT (STILLING WELLS AND HIGHLY SENSITIVE PRESSURE TRANSDUCERS) TO PRODUCE ACCURATE FLOW ESTIMATES. THESE GUIDELINES WILL HELP THE DESIGNER TO DESIGN A SYSTEM WHICH WILL BE CONDUCTIVE TO FLOW MEASUREMENT USING THIS EQUIPMENT.

DESIGNER NOTES AND GUIDELINES:

1. THE DESIGNER MUST ADAPT THE SECTION DRAWINGS TO ADDRESS SITE-SPECIFIC CONDITIONS.
2. THE DESIGNER MUST CONSULT WITH EQUIPMENT MANUFACTURER'S REPRESENTATIVE AND MONITORING PROFESSIONAL OR TECHNICIAN PRIOR TO COMPLETION OF DESIGN.
3. END-OF-BLOCK CATCH BASIN FLOWS SHOULD BE MEASURED WITH THE USE OF STILLING WELLS AND PRESSURE TRANSDUCERS.
4. PRESSURE TRANSDUCERS MAY BE VENTED OR UNVENTED. IF UNVENTED, A NEARBY BAROMETRIC TRANSDUCER OF THE SAME MAKE SHOULD BE INSTALLED FOR ATMOSPHERIC PRESSURE CORRECTION.
5. PVC STILLING WELLS MUST BE PERFORATED BELOW THE INVERT OF THE OUTLET PIPE. PERFORATIONS SHOULD ALWAYS BE ABOVE THE TOP OF THE PRESSURE TRANSDUCER HOUSING TO PROVIDE A PERMANENT WET POOL FOR THE TRANSDUCER.
6. THE STRUCTURE SHALL BE WATER TIGHT. CALIBRATION OF THE OUTLET PIPE WILL BE DIFFICULT IF LARGE VOLUMES OF WATER ARE NEEDED TO INCREASE THE WATER LEVEL IN THE STRUCTURE TO THE INVERT OF THE PIPE WEIR.
7. THE MONITORING STRUCTURE SHOULD BE LARGE ENOUGH TO PROVIDE ACCESS FOR INSTALLATION, MAINTENANCE, AND REMOVAL OF MONITORING EQUIPMENT.

DESIGNER CHECKLIST (MUST SPECIFY, AS APPLICABLE):

- CATCH BASIN TYPE/MATERIAL, DIAMETER, AND DEPTH
- PRESSURE TRANSDUCER TYPE AND SPECIFICATIONS
- CONTROL ELEVATIONS FOR STILLING WELLS AND PRESSURE TRANSDUCERS
- MATERIAL TYPE AND SIZE FOR ALL PIPES AND TUBING
- DIAGRAM WITH ALL OUTLET MONITORING ASSEMBLY COMPONENTS IDENTIFIED OR REQUEST FOR CONTRACTOR SUBMITTAL OF MONITORING ASSEMBLY

NOT FOR CONSTRUCTION - REFER TO USER GUIDE

NOTES COMPONENTS

GC	GC
6.1	6.2



**GREEN INFRASTRUCTURE
TYPICAL DETAILS**

SAN FRANCISCO PUBLIC UTILITIES COMMISSION

DATE
JANUARY 2023

VERSION
3.0

REVISED

**GENERAL COMPONENTS
END-OF-BLOCK MONITORING
DESIGNER NOTES**

DWG NO.

**GC
6.1**

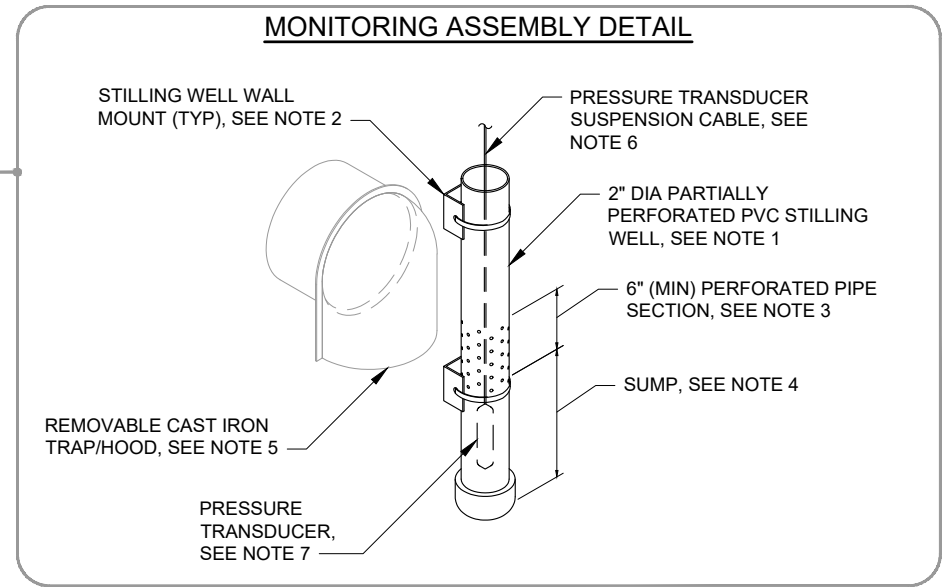
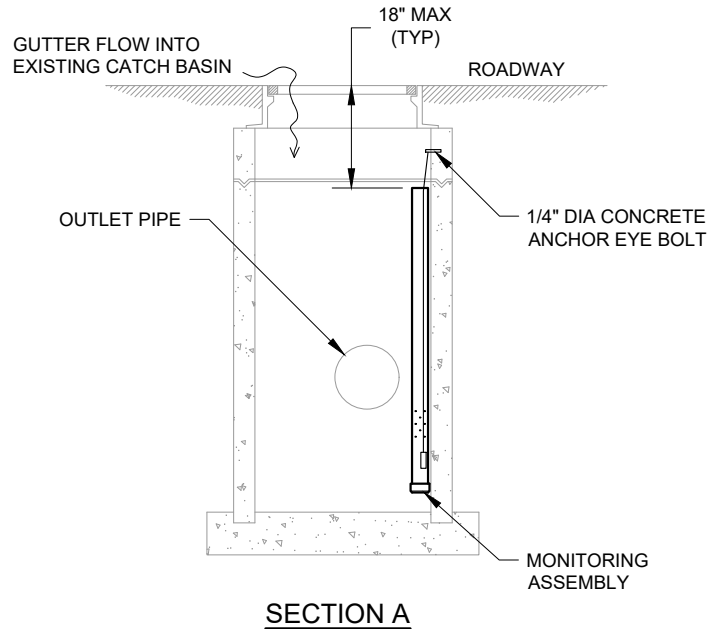
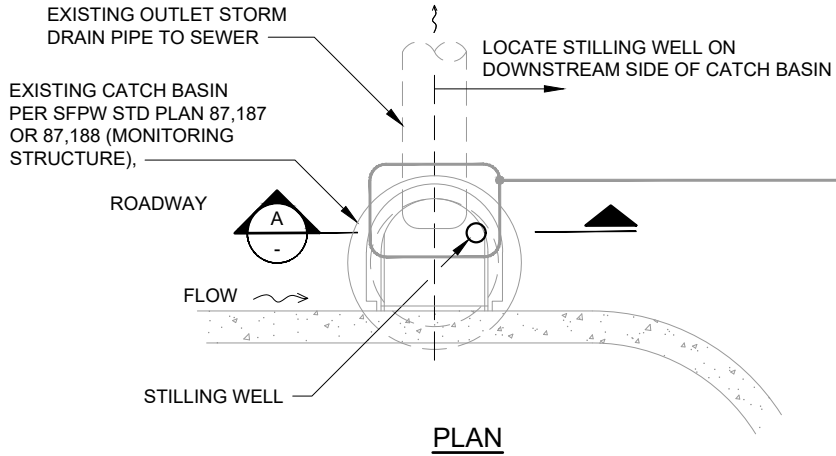

CONSTRUCTION NOTES:

1. STILLING WELL SHALL BE MOUNTED VERTICALLY AND ALL FITTINGS SHALL BE WATERTIGHT.
2. ATTACH STILLING WELL WITH PREFABRICATED METAL STRUT CHANNEL AND PIPE CLAMPS (2 MINIMUM) PER MANUFACTURERS RECOMMENDATION.
3. PROVIDE PERFORATIONS ALONG CIRCUMFERENCE OF STILLING WELL BETWEEN OUTLET PIPE INVERT AND PRESSURE TRANSDUCER SUMP. PERFORATIONS SHALL MEASURE 1/4 INCH DIAMETER (MINIMUM) AT 1 INCH (MAXIMUM) ON-CENTER SPACING, ALL DIRECTIONS.
4. STILLING WELL SUMP SHALL BE NON-PERFORATED AND EXTEND 4 INCHES (MINIMUM) BELOW AND 2 INCHES (MINIMUM) ABOVE PRESSURE TRANSDUCER HOUSING TO ALLOW FOR SEDIMENT ACCUMULATION IN THE BOTTOM OF THE WELL AND PROVIDE A PERMANENT WET POOL FOR THE TRANSDUCER.
5. REMOVABLE CAST IRON TRAP/HOOD SHALL BE NEENAH R-3701 SERIES, NEENAH R-3711 SERIES OR EQUAL. INSTALL TRAP/HOOD PER MANUFACTURERS RECOMMENDATION.
6. PRESSURE TRANSDUCER SUSPENSION CABLE SHALL BE 1/16 INCH COATED STAINLESS STEEL CABLE WITH FERRULED CABLE LOOP AND COMPATIBLE OVAL CARABINER FOR CONNECTION TO CONCRETE ANCHOR EYE BOLT.
7. PRESSURE TRANSDUCER SHALL BE RATED FOR ZERO TO 21 PSI OF PRESSURE AND AN ACCURACY OF ± 0.1 PERCENT FULL SCALE RANGE OR BETTER AT 25°C.

NOT FOR CONSTRUCTION - REFER TO USER GUIDE

NOTES		COMPONENTS	
GC	GC	GC	GC
6.1		6.2	



**GREEN INFRASTRUCTURE
TYPICAL DETAILS**
SAN FRANCISCO PUBLIC UTILITIES COMMISSION

DATE	JANUARY 2023
VERSION	3.0
REVISED	

**GENERAL COMPONENTS
END-OF-BLOCK MONITORING**

DWG NO.
**GC
6.2**